

TM 11-5826-225-35

DEPARTMENT OF THE ARMY TECHNICAL MANUAL

DS, GS, AND DEPOT
MAINTENANCE MANUAL

DIRECTION FINDER SET AN/ARN-83

This copy is a reprint which includes
pages from changes 1 thru 5.

HEADQUARTERS, DEPARTMENT OF THE ARMY

CAUTION

This equipment is transistorized. Before making resistance measurements on the circuits, read the instructions in Paragraphs 2-2 and 2-8.

Change }
No 5 }

HEADQUARTERS
DEPARTMENT OF THE ARMY
Washington, DC, 3 July 1980

**Direct Support, General Support
and Depot Maintenance Manual
DIRECTION FINDER SET AN/ARN-83
(NSN 5826-00-912-4415)**

TM 11-5826-225-35, 17 March 1966, is changed as follows:

1. Remove and insert pages as indicated in the page list below.

Remove	Insert
i.....	i
1-1 and 1-2.....	1-1 and 1-2
1-5 and 1-6.....	1-5 and 1-6
1-13t hrough 1-16.....	1-13through 1-16
1-19 and 1-20.....	1-19 and 1-20
1-22.1 and 1-22.2.....	1-22.1 and 1-22.2
1-27 through 1-30.....	1-27 through 1-30
2-7 through 2-10.....	2-7 through 2-10
2-29 through 2-34.....	2-29 through 2-34
2-39 through 2-42.....	2- 39 through 2-42
3-19 and 3-20.....	3-19 and 3-20
3-23 through 3-28.....	3-23 through 3-31
4-13 through 4-14.4.....	4-13 through 4-14.1
4-25 and 4-26.....	4-25 and 4-26
4-29 and 4-30.....	4-29 and 4-30
5-1.....	5-1
5-5.....	5-5
5-12.7.....	5-12.7
5-12.9.....	5-12.9
5-12.11.....	5-12.11
5-12.13.....	5-12.13
5-12.15.....	5-12.15
5-12.17.....	5-12.17
	5-12.19
	5-12.21
	5-12.23
	5-12.25
	5-12.27
	5-12.29
5-14.....	5-14
5-17.....	5-17
I-1 and I-2.....	I-1 and I-2

2. File this change sheet in front of the manual for reference purposes.

By Order of the Secretary of the Army:

E. C. MEYER
General, United States Army
Chief of Staff

Official:

J. C. PENNINGTON
Major General, United States Army
The Adjutant General

Distribution:

To be distributed in accordance with DA Form 12-36, Direct and General Support maintenance requirements for AN/ARN-83

CHANGE }
No. 4 }

HEADQUARTERS
DEPARTMENT OF THE ARMY
WASHINGTON, DC 20 September 1978

**Direct Support, General Support
and Depot Maintenance Manual
DIRECTION FINDER SET AN/ARN-83
(NSN 5826-00-912-44151)**

This Change current as of 23 May 1978

TM 11-5826-225-35, 17 March 1966, is changed as follows:

1. Title of the manual is changed as shown above.
2. New or changed material is indicated by a vertical bar in the margin.
3. Remove and insert pages as indicated in the page list below.

Remove
1-1 and 1-2
1-7 and 1-8
2-1 through 2-4
2-35 and 2-36
3-27 and 3-28
4-5 through 4-6.11
4-11
4-15 and 4-16.
4-23 through 4-28

Insert
1-1 and 1-2
1-7 and 1-8
2-1 through 2-4
.2-35 and 2-36
3-27 and 3-28
4-5 through 4-6.1
.4-11
4-15 and 4-16
.4-23 through 4-28

4. File this change sheet in front of the manual for reference purposes.

By Order of the Secretary of the Army:

Official:

J. C. PENNINGTON
*Brigadier General, United States Army
The Adjutant General*

BERNARD W. ROGERS
*General, United States Army
Chief of Staff*

Distribution:

To be distributed in accordance with DA Form 12-36, organizational maintenance requirements for AN/ARN-83.

Technical Manual }
 No. 11-5826-225-35 }

HEADQUARTERS
 DEPARTMENT OF THE ARMY
 Washington, D.C., 17 March 1966

**Direct Support, General Support, and Depot Maintenance Manual
 DIRECTION FINDER SET AN/ARN-83**

Reporting of Errors

You can help improve this manual. If you find any mistakes or if you know of a way to improve the procedures, please let us know. Mail your letter or DD Form 2028 (Recommended Changes to Publications and Blank Forms) direct to: Commander, US Army Communications and Electronics Materiel Readiness Command, ATTN: DRSEL-ME-MQ, Fort Monmouth, NJ 07703. A reply will be furnished direct to you.

	Paragraph	page
Chapter 1	FUNCTIONING	
Section I.	General functioning of Direction Finder Set AN/ARN-83	1-1 -1-3 1-1
II	Detailed functioning of Radio Receiver R-1391/ARN-83	1-4 -1-21 1-5
III.	Detailed functioning of additional equipments	1-22- 1-25, 1-22
IV.	Interunit circuit functioning	1-26- 1-32 1-25
Chapter 2.	TROUBLE SHOOTING	
Section I	General troubleshooting techniques	2-1 -2-3 2-1
II.	Troubleshooting Radio Receiver R-1391/ARN-83	2-4 -2-9 2-3
III.	Troubleshooting Direction Finder Control C-6899/ARN-83	2-10 -2-12 2-35
IV.	Troubleshooting Mounting MT-3605/ARN-83 and Inverter, Power, Static CV-2128	2-13 -2-15 2-40
V.	Troubleshooting Antenna AS-1863/ARN-83	2-16 2-43
Chapter 3	REPAIR AND ALIGNMENT	
Section I.	Repairs	3-1 -3-7 3-1
II.	Alignment	3-8 -3-22 3-19
Chapter 4	GENERAL SUPPORT AND DEPOT INSPECTION PROCEDURES	
Section I	General support	4-1- 4-19 4-1
II.	Depot Inspection standards	4-20- 4-21 4-29
Chapter 5.	ILLUSTRATIONS	5-1
Index		1-1

CHAPTER 1 FUNCTIONING

Section 1. GENERAL FUNCTIONING OF DIRECTION FINDER SET AN/ARN-83

1-1. Scope

This manual contains direct support, general support and depot maintenance instructions for Direction Finder Set AN/ARN-83. It includes instructions appropriate to these levels of maintenance for troubleshooting, testing, aligning, and repairing the equipment. The manual also lists tools, materials, and test equipment for maintenance. Detailed functions of the equipment are also covered.

1-1.1. Reporting Equipment Improvement Recommendations (EIR)

EIR's will be prepared using **DA Form 2407**, Maintenance Request. Instructions for preparing EIR's are provided in TM 38-750, The Army Maintenance Management (System). EIR's should be mailed direct to Commander, US Army Communications and Electronics Materiel Readiness Command, ATTN: DRSEL-MA-Q, Fort Monmouth, N.J. 07703. A reply will be sent direct to you.

NOTE

For other applicable forms and records, see paragraphs 1-2 and 1-3 in TM 11-5826-225-12.

1-2. General System Block Diagram Functioning

u. Direction Finder Set AN/ARN-83 includes the components shown in figure 1-1. The general direction of ac power, dc power, and signal flow is also shown. Antenna AS-1863/ARN-83 (fixed loop antenna) contains two pairs of loop antennas displaced 90 degrees. One pair of loops is sensitive to radio signals parallel to the aircraft longitudinal axis, and the other pair of loops is sensitive to signals parallel to the aircraft lateral axis. The two-loop output signals are applied to Radio Receiver R-1391/ARN-83 through an RF inductance

compensator (not supplied as part of direction finder set) which corrects for any electromagnetic field distortion induced into the antenna by metal parts of the Aircraft.

b. Radio Receiver R-1391/ARN-83 (CPN 522-2587-000, -0150) receives directional radio signals from Antenna AS-1863/ARN-83 and nondirectional radio signals from a sense antenna (not supplied as part of direction finder set). When operating as an automatic direction finder (adf), the receiver processes these two RF signals and determines the radial bearing of any radio station tuned in. This bearing data is displayed on the aircraft bearing indicator. The receiver may be operated as an automatic direction finder, a manual direction finder, or as an ordinary broadcast station receiver.

c. Direction Finder Control C-6899 /ARN-83 contains all the necessary controls for remotely selecting the receiver frequency ranges (190-400 kc, 400-850 kc, 850-1750 kc) and operating modes (adf, antenna, or loop), tuning the receiver, adjusting gain, and controlling power bfo operation.

d. Mounting MT-3605/ARN-83, serves as the receiver shockmount and distribution center for ac and dc power, control signals, audio signal, and bearing data, between the receiver and control unit and the aircraft. Inverter, power, static CV-2128/ARN-83, a dc-to-ac inverter in the receiver shockmount, changes 27.5-volts dc primary power into 26-volts, 400-cps power for synchro excitation.

1-3. Overall Functional Block Diagram Analysis

The following is based upon the overall

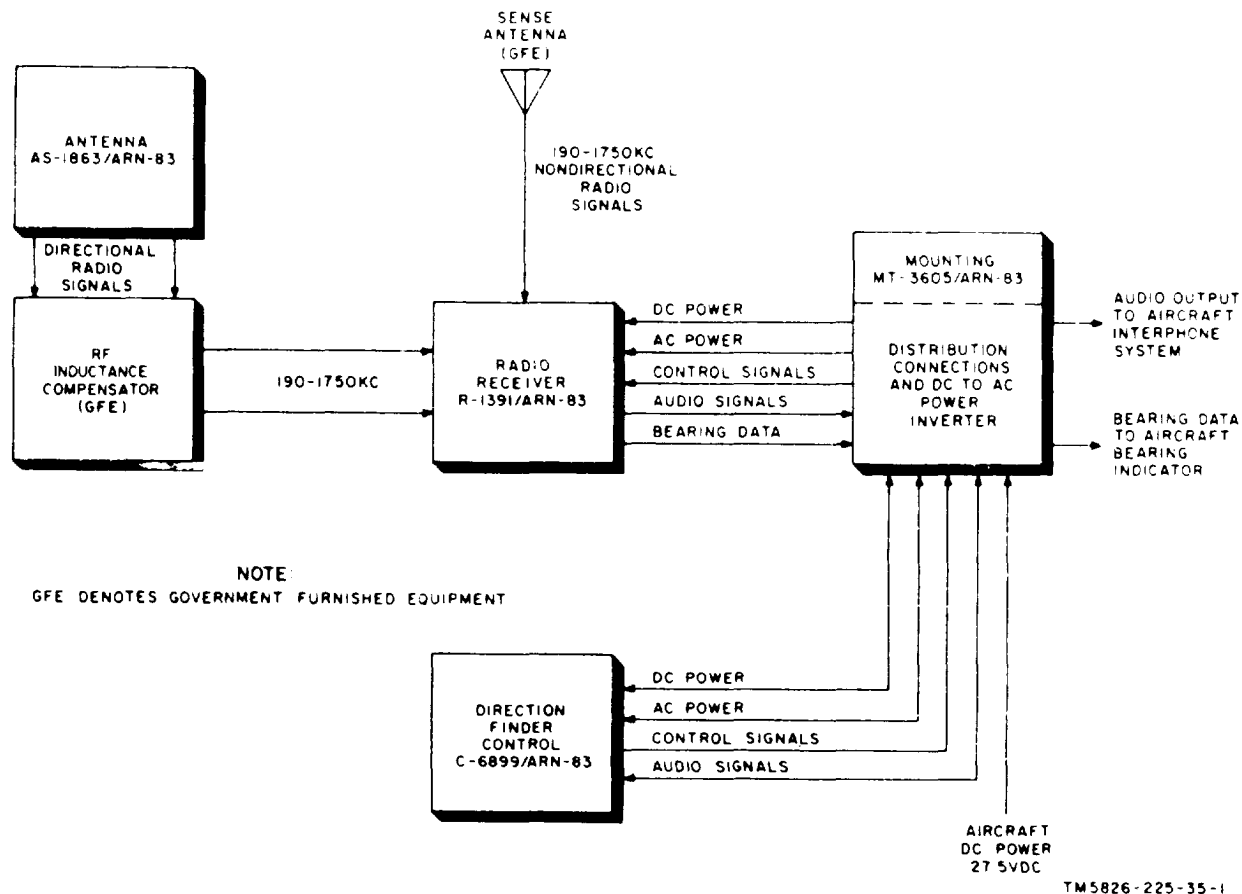

Figure 1-1. Direction Finder Set AN/ARN-83, system block diagram.

functional block diagram in figure 5-2. This diagram shows the equipment signal paths and methods of remote tuning, frequency range selection, and operating mode (function) selection from the control unit.

a. *Operating Mode Control Signal Paths.* The receiver frequency ranges (190-400 kc, 400-850 kc, 850-1750 kc) and operating modes (adf, antenna, loop), are selected by motor B2 which rotates frequency range and function switch S1 through an Autopositioner circuit. Rotary switch S1, containing a number of sections, combines both range and function selection into one switch. Electrical circuits are completed between motor B2 and switches S302 and S304. For each of the three operating positions (adf, antenna, or loop) of function switch S302, switch S1 will rotate and stop on nine possible

positions depending on where range switch S304 is positioned. Since switches S302 and S304 may each be set to three different positions, it requires nine positions of switch S1 (three positions for each operating mode) to cover all frequency ranges and Operating modes.

b. *Automatic Direction Finder Mode Signal Paths* (fig, 5-2),

(1) Radio signals induced in Antenna AS-1863 ARN-83, are impressed on the stator windings of resolver B3. The direction finder set uses a resolver operating as a goniometer rather than using a rotating loop antenna. Rotating the resolver rotor produces a rotating figure-eight RF pattern the same as rotating a loop antenna. The

angular position of the resolver rotor with respect to its stator windings and relative bearing of the radio station, determines the phase and amplitude of RF signal applied to first RF amplifier Q1. Resolver 133 driving bearing synchro transmitter B4 is part of a closed-loop servo system. During adf operation, servo motor B5 runs B3 in one direction or the other until the servo loop error voltage drops to a minimum. At this point resolver B3 will stop on a null.

- (2) Before reaching second RF amplifier Q3, the RF signal output of Q1 passes through a 90-degree phase shift network which insures that the loop antenna and sense antenna RF signals will be in phase or 180 degrees out of phase. The RF output of amplifier Q3 is coupled to balanced modulator CR15 and CR16. Modulation is supplied by two phases of 110-cps signals derived from 110-cps oscillator Q22. The balanced modulator output signal, applied to a sense antenna signal mixing network in push-pull RF amplifier Q2 and Q4, is a double-sideband signal containing upper and lower 110-cps sidebands with the RF carrier absent. After adding the sense antenna RF carrier signal and 110-cps sidebands, a 110-cps amplitude-modulated RF signal is formed with a phase and depth of modulation determined by the angular difference between the resolver rotor full position and the radio bearing of a radio station RF signal source. Omitting the sense antenna, this results in a figure-eight loop antenna RF pattern with two nulls displaced 180 degrees apart. Adding the sense antenna signal, resolves this ambiguity by removing the spurious null and the only null remaining is the true null. The original figure-eight RF pattern then becomes a cardioid pattern.
- (3) The 110-cps amplitude-modulated sense antenna RF signal is mixed in

mixer Q5 with a signal from local oscillator Q6 that is 142.5 kc higher than the RF carrier, resulting in a mixer output of 142.5 kc. This 142.5-kc signal is amplified in a five-stage IF amplifier (Q7 through Q11), demodulated by audio detector CR1 and applied to a three-stage audio amplifier (Q12 through Q14). In adf operating mode, audio gain is controlled by dual gain controls R301-A and R301-B located in the control unit. Audio limiter CR2 limits audio and noise peaks. Meter rectifier CR10 supplies a dc voltage to tuning meter M30 that is proportional to the signal level. Beat frequency oscillator Q21, is a crystal oscillator operating at a frequency of 142.5 kc. Switch S301 on the control unit turns bfo Q21 on by supplying voltages. The bfo frequency beats against the IF frequency in audio detector CR1, while the receiver is being tuned for zero beat.

- (4) Gain is controlled in the push-pull RF amplifier and IF amplifier stages by age voltage derived through age rectifier CR3, first age amplifier Q16, and second age amplifier Q15. Diode CR3 and amplifier Q16 also serve similar purposes to demodulate and amplify the balanced modulator 110-cps sidebands originally modulating the sense antenna RF carrier. The 110-cps signal output of first age amplifier Q16 is also applied to resolver servo amplifier Q17, Q18, Q24, and Q25. Synchronous filter Q19 and Q20, connected between the 110-cps signal path and ground, simulates a variable impedance with a response curve similar to an L-C filter tuned to 110 cps. The two opposing phases of the 110-cps signal applied to the filter from 110-cps oscillator Q22 synchronize the filter to a center frequency of 110 cps. Any deviation in frequency about the center frequency of 110 cps will cause the spurious frequencies to be by-passed to ground.

- (5) The 110-cps signal whose phase varies according to the resolver rotor position is amplified in resolver servo amplifier Q17, Q18, Q24, and Q25 and applied to the control phase winding of servo motor B5. A 110-cps fixed phase signal derived from 110-cps amplifier Q23, is applied to the reference phase winding of motor B5. The two-phase servo motor drives resolver B3 and bearing synchro transmitter B4 in one direction if the variable phase 110-cps voltage leads the reference voltage by 90 degrees and in the other direction if the variable phase voltage lags the reference voltage by 90 degrees. As the resolver rotor apparent null approaches the RF signal source direction, the amplitude of variable phase signal will decrease slowing down servo motor B5 until the resolver rotor null (electrical zero) faces the RF signal source which is the direction of the radio station.

c. Loop Operating Mode Signal Paths (fig. 5-2)

- (1) Setting function switch S302 to the LOOP position also rotates switch S1 to the loop position, transferring the receiver circuits from automatic direction finding mode to manual direction finding mode. In loop operating mode, the operator uses the control unit LOOP switch to manually rotate resolver B3 and the apparent figure-eight antenna loop pattern up to 360 degrees in either direction. The direction or bearing of a radio station is determined either by listening for an aural null while rotating resolver B3 or by watching tuning meter M301 for minimum indication. When null is obtained, the bearing indicator pointer indicates the bearing to the radio station.
- (2) In loop operating mode, RF signals from Antenna AS-1863 AFN-83 pass through resolver B3, first PF amplifier Q1, second PF amplifier Q3, and

push-pull RF amplifier Q2 and Q4. The 90 degree phase shift network and balanced modulator are bypassed. In addition, the sense antenna is disconnected. The mixer, local oscillator, five-stage IF amplifier, audio detector, age circuits, and audio amplifier, operate the same as for adf operation.

- (3) The 110-cps variable phase signal normally used as an input signal to resolver servo amplifier stages Q17 and Q18 is removed by a section of switch S1. Servo motor B5 receives its reference phase 110-cps voltage from 110-cps oscillator Q22 and 110-cps amplifier Q23. The control phase voltage for running servo motor B5 in either direction, is derived through LOOP switch S303. One connection of switch S303 receives 110-cps (phase 1) voltage and another connection receives a 110-cps voltage 180 degrees out of phase (phase 2) with the first voltage. Positioning LOOP switch S303 either right or left connects a 110-cps voltage of the proper phase to push-pull resolver servo amplifier Q24 and Q25. This voltage causes servo motor B5 to rotate resolver B3 clockwise or counterclockwise to a null. Two nulls spaced 180 degrees apart will be encountered resulting in a 180-degree ambiguity of the radio station bearing. On a null, the radio station is either in the direction of the bearing indicator pointer or 180 degrees from this direction.

d. Antenna Operating Mode Signal Paths (fig. 5-2). When function switch S302 is set to the ANT (antenna) position, all loop antenna RF signal circuits ahead of push-pull RF amplifier Q2 and Q4, are disconnected and only the nondirectional sense antenna is used. The direction finder set may then be used for radio range or broadcast station reception. In antenna operating mode, the resolver and bearing indicator are inoperative.

e. Receiver Remote Tuning Signal Paths (fig. 5-2) Receiver tuning capacitor C1 containing

five sections, is positioned by a closed-loop servo system through remote control circuits in Direction Finder Control C-6899/ARN-83. The rotor of tuning synchro transmitter B301 is mechanically coupled to the TUNE control knob and its stator windings are connected to tuning synchro control transformer B1. The rotor output signal of B1 is amplified through tuning servo amplifier Q26 through Q29 and applied as the control phase to servo motor-

generator set MG1. The rotor of B1 geared to MG1 and C1 forms the followup portion of the closed servo loop. Synchro voltage excitation for B301 and B4, as well as for the reference phase of MG1, is supplied by 26 volts at 400 cps derived from the dc-to-ac inverter in the receiver mount. The receiver dc voltage regulator Q30 and Q31 supplies regulated voltages to transistors in the equipment.

Section II. DETAILED FUNCTIONING OF RADIO RECEIVER R-1391/ARN-83

1-4. General

Radio Receiver R-1391/ARN-83, is the main operational unit of Direction Finder Set (AN/ARN-83). The receiver is a single-conversion superheterodyne low frequency receiver, tunable from 190 kc to 1750 kc in three ranges. In automatic direction finding (adf) mode, it processes RF input signals from a directional loop antenna (fixed) and a nondirectional sense antenna to determine the bearing of radio stations. The loop antenna RF output is impressed on the stator windings of a resolver (goniometer) driven by a closed loop servo mechanism. A phase comparison between RF signals, from the resolver rotor winding and the sense antenna signals, determines whether the resolver rotor electrical zero or null position is either to the right or left of the direction of radio station signals. After this is determined, the servo mechanism rotates the resolver in the direction required to reach a null, which is the direction of the radio station. A synchro transmitter, geared to the resolver, transfers bearing data to the aircraft bearing indicator. The Mock diagram illustrated in figure 5-2, shows the relationship of all functional circuits in the receiver. The following paragraphs contain detailed circuit functions in the same order as the direction of signal flow depicted in figure 5-2. A complete Schematic of the receiver is shown in figures 5-10.1, 5-10.2, 5-10.3, and 5-10.4.

1-5. Receiver Loop Antenna and Goniometer Circuit Functioning (fig. 5-3)

a. Antenna AS-1863/ARN-83, comprises two

fixed loop antennas mounted at right angles to each other with loop 2 sensitive to radio signals along the aircraft longitudinal axis and loop 1 sensitive to radio signals along the aircraft lateral axis. Each loop antenna is terminated in a stator winding of resolver B3. The rotor (L3) of B3 is mechanically coupled to a servo mechanism capable of rotating it through 360 degrees with its coupling to L1 and L2 varied accordingly. The combination of L1, and, and L3, is called goniometer. Assume that loop 1 is along a line directly north and south, and loop 2 is along the east-west line. If a radio station RF source is north of loop 2, maximum signal will be induced in loop 2 and minimum signal in loop 1 (fig. 1-2). A current will flow in winding L2 of resolver B3 and none will flow in L1. If the rotor (L3) of B3 is rotated so that maximum coupling to L1 occurs, no signal will be induced in L3 and if a pointer was attached to the rotor of B3 (assuming proper orientation), one end of the pointer would indicate 0 degrees (north) on a 360-degree dial and the other end, would point 180 degrees or south. If the direction of a radio station is at a bearing of 135 degrees (fig. 1-2), the bearing is not perpendicular to the plane of either loop 1 or loop 2. This will induce a signal voltage in each loop with a phase difference of 180 degrees and equal signal amplitudes. Maximum signal will be induced in the rotor winding of B3 when it is coupled to either L1 or L2 and minimum signal output will result when the rotor apparent null is positioned for minimum coupling to both L1 and L2. The resolver functions as a miniature rotating figure-eight loop antenna pattern and the

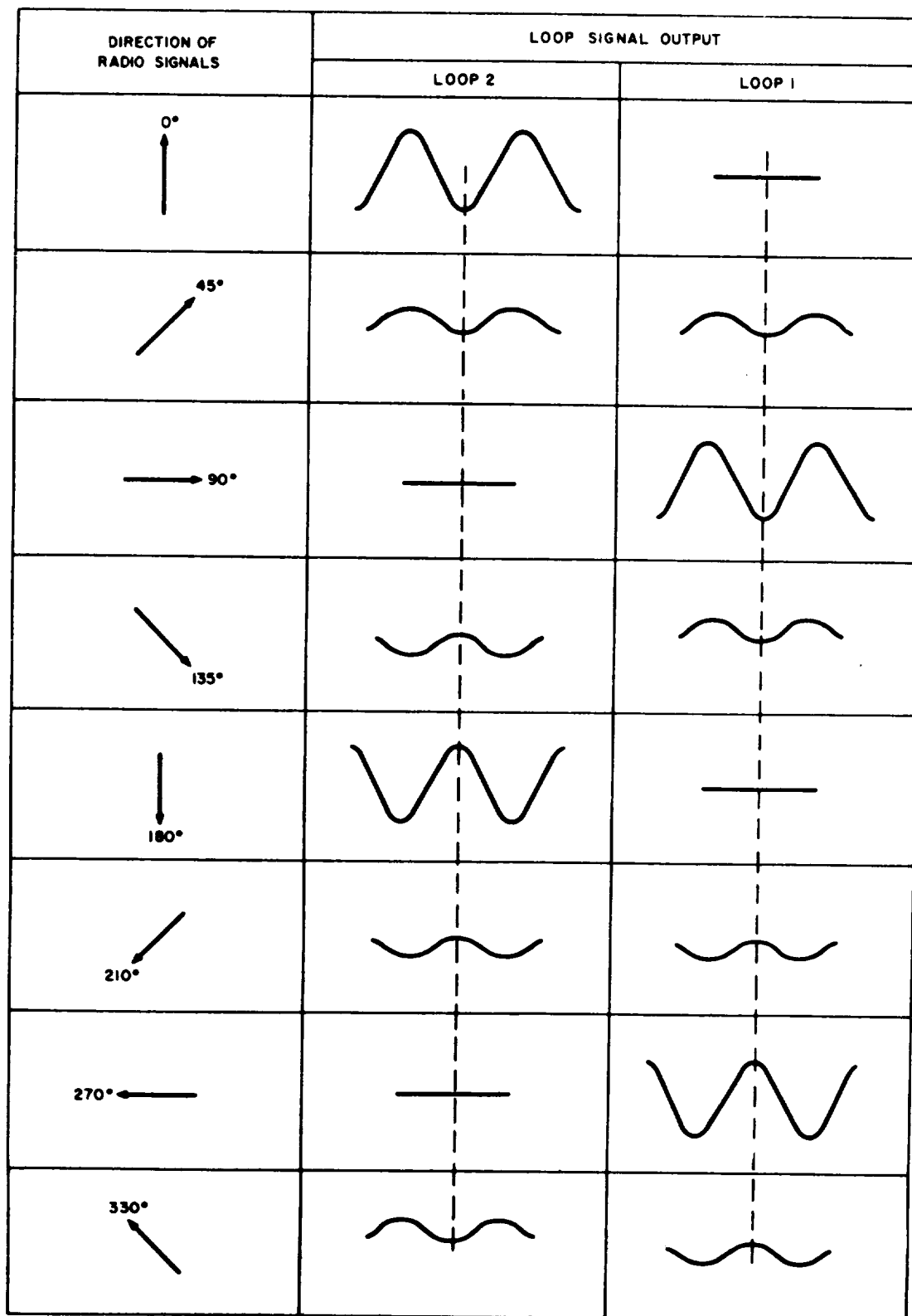

TM 5826-22S-35-4

Figure 1-2 Relative phase and magnitude of loop antenna output signals.

phase of RF output shifts 180° as the null points are crossed, accomplishing identical results as a rotating loop antenna. Figure 1-2 shows the relative phase and magnitude of loop antenna signals for different radio station bearings.

b. The rotor winding output signal of resolver B3 is connected in push-pull to the grounded center tap primary of RF transformer T1, T2, or T3, depending on the position of frequency range and function switch wafer S1-F. Switch S1 is motor-driven through an autopositioner system (para 1-24). Rear switch wafer S1-G, switches the proper center-tapped secondary windings of T1, T2, or T3 to variable tuning capacitor C1-B and the base of Q1. Front switch wafer S-IG, connects unused transformer secondary windings to B+. Trimmer capacitors C2, C3, and C4 adjust frequency ranges at the high end of the range and slug adjustments in RF transformer secondaries set the low end of ranges. Resistors R1 and R2 supply bias to Q1 through the transformer secondaries and rear switch wafer S1-G. The resolver RF output signal of Q1 is applied to second RF amplifier stage Q3 through a phase shift network.

1-6. Phase Shift Network and Second RF Amplifier (fig. 5-4)

a. In the adf mode of operation, the resolver RF is amplified by first RF amplifier Q1, developed across T21, and applied to the base of the second RF amplifier Q3 through C159. The phase of the signal on the base of Q3 must lag the phase of the input signal by 90° . This action is accomplished in the 190- to 400-kc range by the combined phase shift of T21, C159, and C161; and in the 400- to 850-kc range of the combined phase shift of T21, C159, and C162; and in the 850- to 1,750-kc range by the combined phase shift of T21 and C159. The 90° phase lag is required to insure that the input RF signal is either exactly in phase, or 180° out-of-phase, with the signal from the sense antenna. The signal on the base of Q3 is amplified and applied to the balanced modulator (para 1-7).

b. In loop operating mode, rear switch wafer S1-E shorts out the phase shift network to avoid signal attenuation. The phase of RF signal is not important because the sense antenna is not used. Base and emitter bias for Q3 is established by resistors R4 and R98.

c. In the ant mode of operation, the supply voltage is removed from RF amplifiers Q1 and Q3 so the resolver RF is not passed. Thermistor RT2 stabilizes bias and transistor gain.

1-7. Balanced Modulator (fig. 5-4)

a. Since a resolver develops a figure-eight RF pattern with two nulls spaced 180° apart, it is necessary to change this pattern to a cardioid pattern having one null and thus remove the ambiguity of two nulls. If a nondirectional sense antenna RF signal is employed in cooperation with the loop signal, then a suitable phase comparison system can determine which is the correct null and whether the radio station is either to the right or left of the true null. This is partially accomplished with a balanced modulator in which the resolver RF output signal is modulated by a 110-cps audio signal and whose output contains only upper and lower 110-cps sidebands with the RF carrier absent. The phase of these sidebands depends on the phase of resolver RF output signal which changes phase by 180° as the resolver rotor rotates past each null in the figure-eight pattern. Combining the 110-cps sidebands with the fixed phase of an RF carrier signal furnished by the sense antenna will produce two 110-cps amplitude modulated waveforms 180° out-of-phase with each other.

b. In figure 5-4, the amplifier resolver RF signal from Q3, is applied to the anodes of diodes CR15 and CR16, through isolating capacitors C11 and C12. A 110-cps modulating signal of one phase is also impressed on the anode of CR15 through R64 and rear switch wafer S1-D. Variable resistor R10 balances the modulator output circuit by compensating for slightly different values of resistances in each leg of the bridge circuit. A 110-cps modulating signal 180° out-of-phase (phase 2), is impressed on

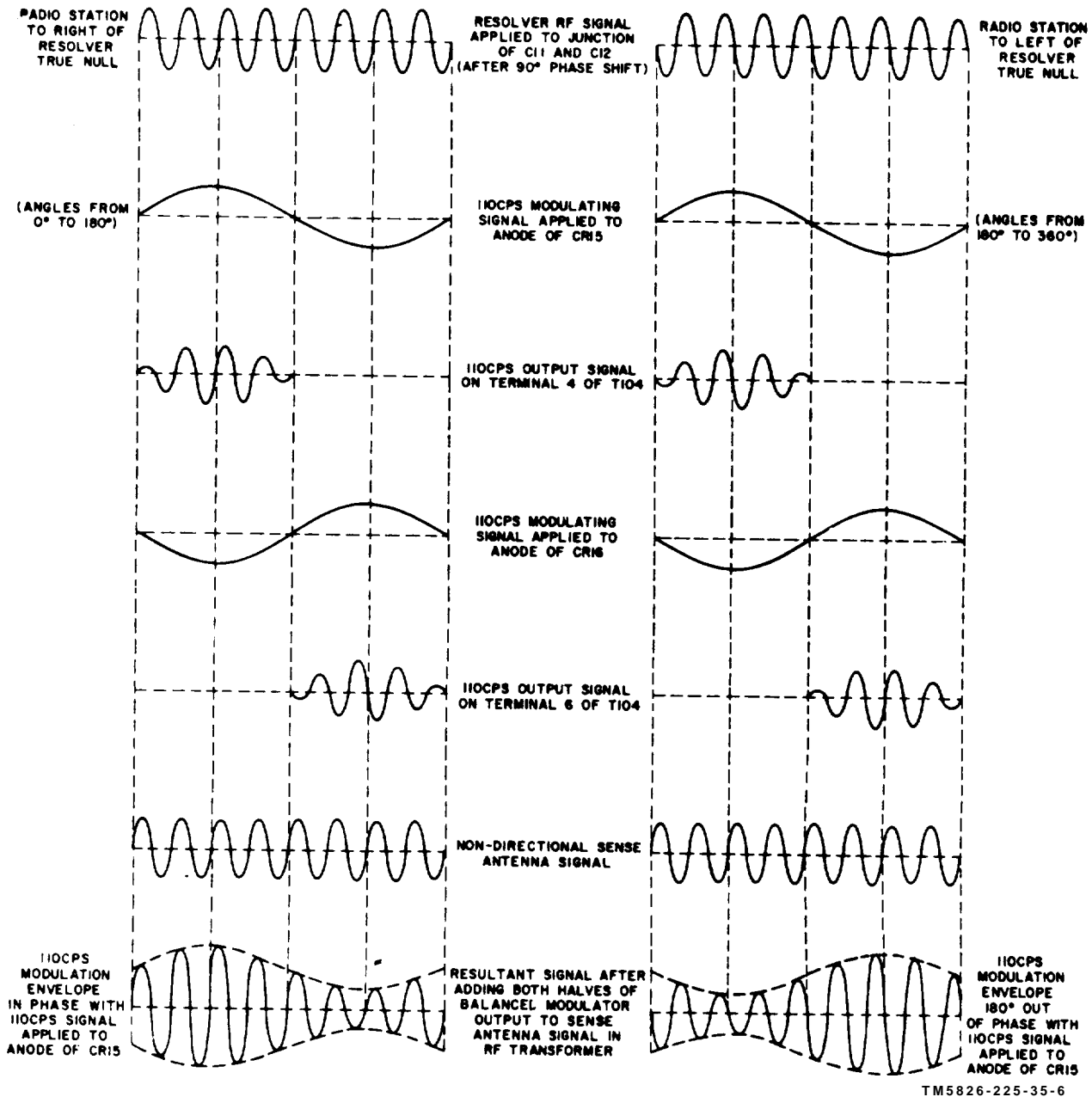

Figure 1-3. Balanced modulator waveforms.

the anode of CR16 through R8 and front switch wafer S1D. For ease of discussion, the cathodes of CR15 and CR16 are assumed to be connected through R9 and R10 to opposite ends of center-tapped RF transformer T104.

c. Not considering the RF carrier signal, diode CR15 is forward-biased during the positive half cycle of the 110-cps signal, and diode CR16 is reverse-biased from the other 110-cps signal applied in phase opposition. During the

next cycle, conditions are exchanged with diode CR15 reverse-biased and CR16 forward-biased. For the first set of conditions, a positive-going RF carrier signal will aid conduction in CR15, but not in CR16. The 110-cps signal of opposite phase are applied to the diodes in push-pull while the single-phase RF carrier signal is applied in series of single-ended fashion. Due to this relationship of signals, the carrier signal on terminal 4 of T104 will be equal in magnitude to that appearing on terminal 6; however, the two signals will be 180° out-of-phase and will cancel in the primary of T104 yielding a 110-cps suppressed carrier signal (110-cps sidebands) in the secondary of T104. If the 110-cps signal is negative on CR15 and positive on CR16, a positive going carrier signal will cause conduction in diode CR16 and not in CR15. This will result in another set of 110-cps sidebands 180° out-of-phase with the previous set of 110-cps sidebands.

d. The waveforms in figure 1-3 shows signal polarities at the input and output of CR15 and CR16 when the radio station RF signals source (from sense antenna) is either to the right or left of the resolver apparent null. The 110 cps on terminal 4 of T104 (extreme left in fig. 1-3) appears for one positive cycle of resolver RF output signal for a radio station RF signal source from 0° to 180° (to right) away from the resolver true null. The 110-cps signal on terminal 4 of T104 shown to the right in figure 1-3, appears 180° later for a radio station RF source from 180° to 360° away from (to the left) of resolver null.

e. Combining the variable phase 110-cps sidebands with a nondirectional sense antenna fixed phase signal, yields the lower waveforms shown in figure 1-3. It will be observed that for a radio station RF signal source to the right of resolver null, the resolver and sense antenna RF signals are in phase. For a radio station to the left of resolver null, the resolver and sense antenna signals are 180° out-of-phase. The output of diode CR15 (fig. 5-4) into the secondary of T104 is positive going when the sense antenna signal is positive, and negative when the latter is negative. Hence the sense antenna and 110-cps signals add to yield an outward 110-cps

modulation envelope as shown in figure 1-3. The output of diode CR16 into the secondary of T104 is opposite in phase to the sense antenna signal and subtracts to yield an inward 110-cps modulation envelope. Ultimately, at the output of the servo amplifier furnishing power for driving a two-phase servomotor geared to the resolver, the phase relationship of the 110-cps modulation envelope will determine which direction the resolver will rotate to a null.

f. If any radio station audio modulating the resolver RF signal is present, it will not pass through the balanced modulator (adf operation). Audio modulation comes over the sense antenna RF carrier. In manual direction finding mode (loop), rear switch wafer S1-E shorts out the 90° phase shift network (fig. 5-4) and applies the resolver RF signal to Q3 directly. Switch wafer S1-D removes the two 110-cps signals and segment X of front switch wafer S1-E shorts out CR15 and R9 comprising one half of the balanced modulator. The resolver RF signal and any modulation present, passes through RF transformer T104. In loop mode, the sense antenna is not used. In antenna operating mode, only the sense antenna signal is used and the resolver signal is disconnected.

1-8. Sense Antenna Input Network (fig. 1-4)

a. In adf operating mode, the balanced modulator 110-cps sidebands are applied in push-pull to the primaries or RF transformers T104, T105, or T106, through segments of rear switch wafer S1-0, depending on the frequency range selected. The sense antenna signal may be connected to either pin A or pin F of connector J1 depending on the capacity of the sense antenna and its cabling. If the sense antenna and cabling has a capacity of 270 micromicrofarads, pin A of J1 is used. Under this condition, the sense antenna signal is applied to terminal 2 of a transformer secondary through L25 and switch wafers S1-R and S1-C. Coupling inductances L25, L28, and L30, supply the necessary impedance for the 190-to 850-kc frequency range. In loop operating mode, the sense antenna input is grounded through switch wafer S1-N. Rear switch

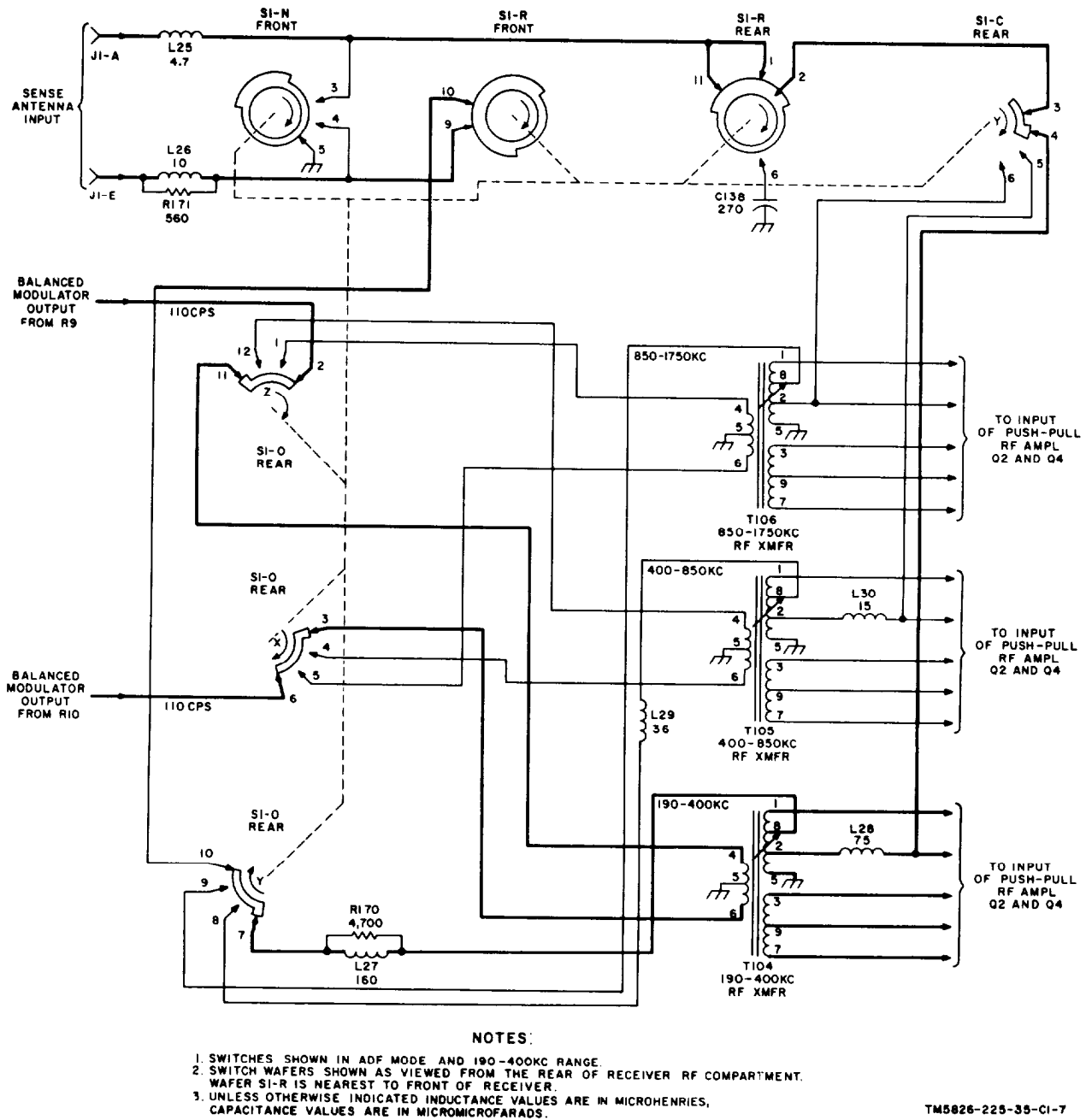

Figure 1-4. Sense antenna and balanced modulator signal mixing network, schematic diagram.

wafer S1-R substitutes C138 in place of the antenna to prevent any detuning effects.

b. If the sense antenna and cabling has a capacity of 150 micromicrofarads, pin E of

J1 is used. The sense antenna signal is then impressed on terminal 8 (a higher impedance tap from ground) of an RF transformer through switch wafers S1-R (front) and S1-

0 (rear). Inductor L26 in combination with L27 and L29, furnish the necessary impedance for these frequency ranges. The 110-cps amplitude modulated sense antenna RF carrier signal appears on terminals 3, 7, and 9 of the transformer secondary (T104, T105, or T106) and is applied in push-pull to a push-pull RF amplifier.

c. In antenna operating mode, only the sense antenna is used and no signal appears on the RF transformers primaries. In loop operating mode, switch wafer S1-N grounds the sense antenna inputs and the resolver RF output signal, shunted on one side of the balanced modulator (fig. 5-4), appears as a single-ended signal on segment Z of rear switch wafer S1-0. This RF signal is applied to terminal 4 of a switched transformer primary.

1-9. Push-Pull RF Amplifier

(fig. 5-5)

a. The balanced modulator 110-cps sidebands applied in push-pull to the primary winding of T104, T105, or T106 are mixed with the sense antenna signal in the transformer secondary windings. Front switch wafer S1-C shorts unused secondary windings to ground. Segment X of rear switch wafer S1-C switches tuning capacitor C1-A to different sets of secondary windings for tuning the sense antenna input circuit. Trimmer capacitors C16, C17, and C18, set the high frequency end of the ranges, and adjustable slugs in the transformer windings set the low end of ranges.

b. The composite 110-cps modulated sense antenna RF carrier signal appears in push-pull on terminal numbers 3 and 7 or the RF transformer secondary winding selected, and is applied to the bases of Q2 and Q4 through segments of Z rear switch wafers S1-C and S1-N. Segment Y of rear switch wafer S1-N switches base bias voltage to Q2 and Q4 through a centertap on the transformer secondary. In either loop or antenna operating mode, RF gain is manually controlled with a dc bias derived from the RF gain potentiometer located in the control unit. This dc voltage is applied through R117 to the emitter circuits of Q2 and Q4. In adf operation, the

dc bias is fixed and RF gain cannot be manually controlled. In all operating modes, base and emitter voltages are controlled by an age voltage applied through R14 and R135. Balance adjustment R136 balances emitter currents of Q2 and Q4. The push-pull RF output signals of Q2 and Q4 are applied to the center-tapped primary of T107, T108, or T109.

1-10. Mixer Input Tuned Circuits (fig. 5-6)

a. To achieve the proper selectivity and bandpass over each frequency range, the push-pull RF amplifier and mixer stages are coupled through pairs of RF transformers. Coupling between transformer pairs T107 and T10 or T109 and T12 is determined by capacitors C152 and C96, respectively. These capacitors have the effect of making the response curve on each side of resonance either wider or sharper. Inductor L8 between T108 and T11 serves a similar purpose. Coupling between transformer pairs is at a low impedance and not susceptible to electrical interference from external sources.

b. Since all transformer pairs are essentially identical, only one pair (T107 and T10) is discussed. The slug-tuned secondary of T107 sets the low frequency end of the 190- to 400-kc range for the single-ended output of the push-pull RF amplifier. Trimmer capacitors C23 and fixed capacitor C90, determine the high end of the 190- to 400-kc range. Variable capacitor C1-D (tuning) tunes the RF amplifier output over the frequency ranges. Segment Z of rear switch wafer S1-P switches C1-D to T107, T108, or T109. Front switch wafer S1-P shorts unused transformer secondary windings to ground.

c. The RF signal, coupled from T107 to the slug-tuned primary of T10, appears on the secondary winding of T10 and is applied to mixer Q5 through C29 and segment X of front switch wafer S1-I. This switch wafer switches mixer Q5 to the output of T10, T11, or T12. The adjustable slug in T10, sets the low end of the 190- to 400-kc frequency range, and capacitors C26 and C93 set the high frequency end. Variable capacitors C1-C (tuning) tunes

the mixer input over the frequency ranges. Segment Y of front switch wafer S1-I switches C1-C to the primaries of transformers T10, T11, and T12. Rear switch wafer S1-I shorts unused transformer primary windings to ground.

1-11. Local Oscillator
(fig. 5-7)

a. Local oscillator Q6 and associated parallel resonant tuned circuits oscillates at a frequency 142.5 kc higher than the 190- to 1,750-kc RF carrier signal. The oscillator operates as a Hartley oscillator with feedback from collector to emitter through tapped coils L3, L4, or L5 as selected by segments X and Z of front switch wafer S1-J. Rear switch wafer S1-J shorts unused oscillator coils to ground. Each parallel resonant oscillator circuit has an adjustable slug-tuned RF coil for setting the low end of the frequency ranges and a trimmer capacitor for adjusting the high end of frequency ranges. In some instances fixed capacitors are used for padding the low and high end of frequency ranges. Segment Y of front switch wafer S1-J switches variable capacitor C1-E (tuning) for tuning each parallel resonant circuit.

b. Oscillator Q6 receives emitter bias and reverse base bias through R127, R20, R19, and R18. The base of Q6 is partially grounded for RF by capacitor C10. Changes in emitter current reflect on the base bias, causing collector-to-emitter feedback to have the same results as positive feedback from a collector to base. The oscillator RF output signal is applied to the base Q5 mixer off through coupling capacitor C31 and isolating resistor R17.

1-12. Mixer
(fig. 5-7)

Mixer Q5 mixes the local oscillator frequency of 332.5 to 1,892.5 kc with the 190- to 1,750-kc RF signal and provides a difference frequency of 145.2 kc which is the intermediate frequency (IF). This frequency contains 110-cps modulation from the balanced modulator and any audio modulating the sense antenna RF carrier signal (assuming adf operation).

1-12 Change 1

The collector of Q5, is coupled through a tap on IF transformer T13. Transformer T13 is fixed-tuned to a center frequency of 142.5 kc and has sufficient bandwidth to pass all the sidebands. The 142.5-kc output of T13 is applied to first IF amplifier Q7 through IF gain adjust variable resistor R90 which sets maximum signal level. Transistor Q5 receives emitter and base bias voltage through R126, R16, R15, and R21. Base and emitter bias voltage filtering is provided by capacitors C115 and C 33.

1-13. IF Amplifiers

a. *First and Second IF Amplifiers (fig. 1-5).* The 142.5-kc signal from mixer Q5 passes through capacitor C110, is amplified by first IF amplifier Q7, and applied through fixed tuned IF transformer T14 and capacitor C48 to second IF amplifier Q8. The R166 to output from Q8 is applied through fixed tuned IF transformer T15 and capacitor C51 to third IF amplifier Q9. Transformers T14 and T15, have a resonant frequency of 142.5 kc with sufficient bandwidth to pass all of the audio sidebands. In all operating modes of the direction finder set, the gain of Q7 and Q8 is controlled by agc voltage applied to the bases through R24 and R26, respectively. This voltage becomes more positive for decreasing gain or less positive (more negative) for increasing gain. In loop and antenna operating modes, the gain of Q7 and Q8 in addition to being controlled by an agc circuit, can also be manually controlled by voltage derived from the control unit gain control. This voltage, applied through low-pass filter L12 and C113, controls both emitter and base bias of Q7 and Q8. In adf mode, only audio gain can be manually controlled.

b. *Third, Fourth, and Fifth IF Amplifiers (fig. 5-8).* The circuitry of IF amplifiers Q9, Q10, and Q11 is similar to the first and second IF amplifiers, with the exception that amplifier gain is fixed with emitter and base bias voltages and cannot be controlled automatically or manually. After the 142.5-kc signal has been amplified in the second IF amplifier, it is further amplified by Q9, Q10, and Q11, and

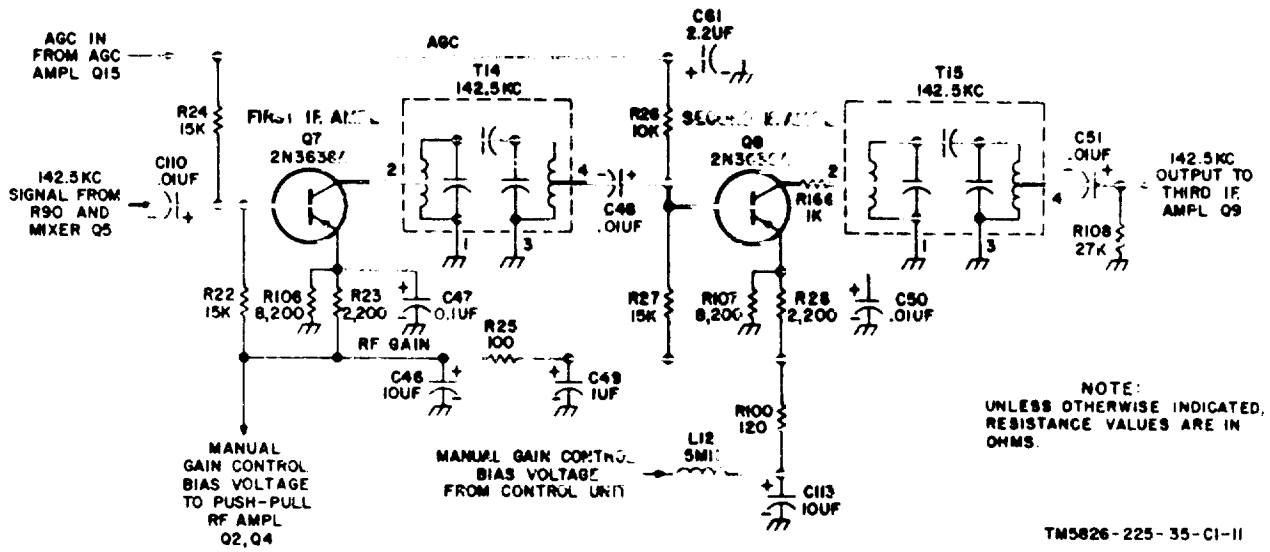

Figure 1-5. First and second IF amplifier stages, schematic diagram.

applied to the audio detector (para 1-14). At the output of IF transformer T17, a 142.5-kc signal is rectified by meter rectifier CR10 and applied through resistor R40 to tuning meter M301 in the control unit for signal level indication. A second 142.5-kc signal, taken from T17, is used for developing age voltage (para 1-16).

1-14. Bfo, Detector, and Limiter, (fig. 1-6)

a. *Beat Frequency Oscillator.* Bfo is an electron-coupled, crystal-controlled oscillator with a fixed operating frequency of 142.5 kc. The feedback to sustain oscillation is from the collector to base through crystal Y1 and capacitor C89. Crystal Y1 and inductor L11 comprises the tank circuit. At the resonant frequency of 142.5 kc, the phase shift of the collector-to-feed-base feedback signal is sufficient to cause oscillation. When the control unit bfo switch is turned on, +16.7 volts dc supplies emitter and base bias voltages to Q21, turning it on. The 142.5-kc output signal is heterodyned with the IF amplifier output frequency in the audio detector. As the receiver is tuned for

zero-beat, the IF frequency shifts a few kilocycles about its nominal 142.5-kc center frequency.

b. *Audio Detector and Limiter.* The IF amplifier output signal and bfo output signal (if the bfo is on), pass through impedance network Z1 to the snode of audio detector CR1. Impedance network Z1 is fixed-tuned with a bandwidth sufficient to pass the bfo frequency and the IF frequency shift caused by tuning the receiver. In addition, Z1 provides impedance matching. Diode CR1 passes the positive half cycles of the audio originally modulating the IF frequency. Capacitor C56 bypasses the IF frequency. The low-pass filter, comprising R36, C57, R37, C157, and L22, filters the audio signal applied to the audio amplifier. Since diode CR1 only passes positive half cycles, the anode of audio limiter CR2 will likewise be positive. The cathode of CR2 also becomes positive with a lower amplitude of signal because of voltage divider R38 and R39. When positive-going audio signals peak occur, the anode of CR2 becomes more positive and its cathode less positive (more negative), causing CR2 to conduct through R39 and limit the audio signal.

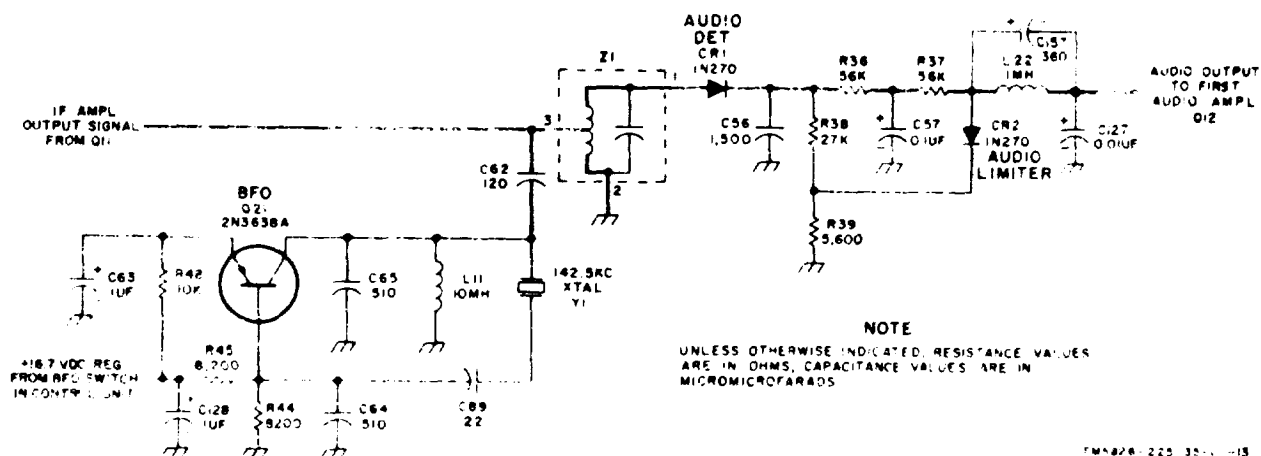

Figure 1-6. Adio detector, limiter, and bfo, schematic diagram.

1-15. Audio Amplifiers

(fig 1-7)

a. Audio amplifiers Q12, Q13, and Q14 amplify the audio signals to a level of approximately 100 milliwatts for the aircraft interphone system. After detection, the audio signal is amplified by Q12 and applied through C84 and af gain adjust potentiometer R82, to the base of Q13. After further amplification by Q13 and Q14, the audio signal from output transformer T20 is attenuated through audio gain potentiometers in the control unit and applied to the interphone system. The output impedance is a constant 600 ohms. In loop operating mode, rear switch wafer S1-L connects capacitor C111 in shunt with terminals 5 and 3 of output transformer T20 to reduce audio output level for sharper aural nulls.

b. Emitter and base bias voltages for Q12 are established by resistors R80, R79, and R78. Resistor R85 furnishes emitter bias for Q13, and base bias is established by voltage divider R84, R82, and R83. Transistor Q14 receives forward base bias voltage through divider R87 and R88. The primary of T20 is the collector load impedance for Q14.

1-14 Change 1

1-16. Automatic Gain and Receiver Muting

(fig. 1-8)

a. Automatic gain control voltage is applied to the bases of the push-pull RF amplifier and first and second IF amplifiers. This voltage is derived by rectifying both the 110-cps variable phase signal developed in the balanced modulator (para 1-7) and any audio from a radio station modulating the receiver IF frequency. The rectified voltage is amplified through a dc amplifier and then used as a gain control voltage.

b. The 142.5-ke signal at the output of IF transformer T17 is superimposed on a positive dc voltage introduced through voltage divider R41 and R42. This dc voltage in addition to providing forward bias for age rectifier CR3, also biases the base of NPN transistor Q16 in the forward direction. After rectification or detection by CR3, positive half-cycles of audio frequencies, including 110 cps up through voice frequencies, appear on the base of Q16. The total positive dc voltage level at the base of Q16 increases as the IF amplifier signal level increases. This increases the

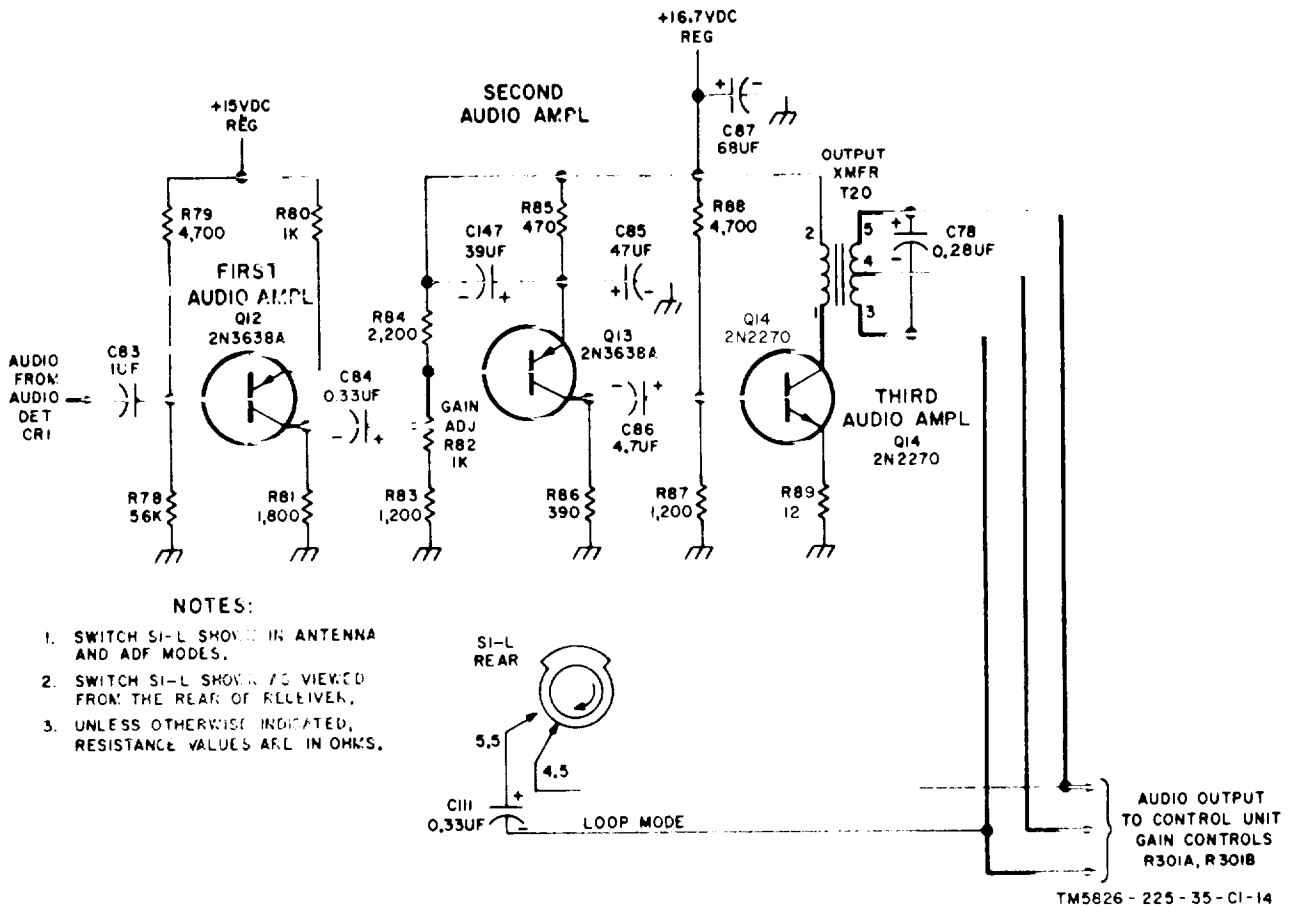

Figure 1-7. Audio amplifier, Schematic diagram,

forward base bias and collector current of Q16. The voltage drop through temperature stabilizing thermistor RT3 and R96 reduces the collector voltage of Q16, which in turn reduces forward bias on the base of Q15. As a result, the collector voltage of Q15 rises in a positive direction, biasing the bases of Q2, Q4, Q7, and Q8 more positive and decreasing gain. Resistor R46 and the emitter-to-collector resistance of Q15 functions as a voltage divider for the bases of the controlled transistors. Decreasing the base bias of Q15, decreases the voltage drop through R47 and R46 resulting in a higher collector voltage. If the IF amplifier output signal level drops, less forward base bias appears on Q16 and its collector voltage will rise driving Q15 into saturation. The increased emitter current and voltage

drop through R47 and R46 will reduce the collector voltage and positive base-bias on the controlled stages, resulting in higher gain. No audio signals appear in this circuit since they are bypassed to ground through capacitor C60. Transistor Q16 also serves as an emitter follower supplying a 110-cps signal for the synchronous filter (para 1-17).

c. When either the control unit function switch or range switch is set to a different position, operation of range and function switch driving motor B2 would ordinarily inject noise into the receiver circuits if a muting circuit was not used. Operating motor B2 applies +27.5 volts dc through muting rectifier CR5 and resistor R116 to base of Q16, driving Q16 into saturation. This reduces forward base

bias on Q15, resulting in a higher agc voltage. The noise produced by motor B2 is then eliminated.

1-17. 110-Cps Variable Phase Signal and Synchronous Filter (fig. 1-9)

a. The 110-cps variable phase signal and other audio frequencies modulating the 142.5-kc IF amplifier frequency, are detected by age rectifier CR3 and applied to the base of first age amplifier Q16. In addition to serving as an age rectifier for audio frequencies (para 1-16), diode CR3 also detects the 110-CPS variable phase modulation envelope originally developed in the balanced modulator (para 1-7). The 110-cps signal output of CR3 appearing in the same phase on the emitter of Q16, is applied through R145, C75, R66, and C125 to the servoamplifier furnishing power for the servo motor geared to a resolver. Since undesirable audio frequencies other than 110 cps may be present, a 110-cps synchronous filter is used to remove these frequencies.

b. Transistors Q19 and Q20 operate as an electronic switch gated and synchronized by two opposite phases of 110-CPS sine wave signals de-

rived from a 110-CPS oscillator. The synchronous filter causes the junction connection of capacitors C76 and C77 to assume the characteristics of an LC filter tuned to a center frequency of 110 cps. There is maximum signal transfer at 110 cps with response falling off at frequencies above or below this frequency.

c. The phase of the 110-CIM signal applied through capacitors C76 and C77 to the collectors of Q19 and Q20 may be in-phase, or out-of-phase, with either one of the 110-cps signals applied to the bases of Q19 and Q20. Assume that phase 1 on the base of Q20 is positive-going, and phase 2 on Q19 is negative-going. Every half cycle, these phases will change while the 110-cps variable phase signal may or may not change phase at the same time. If the 110-cps variable phase signal on capacitor C77 is positive-going and in phase with phase 1 of the 110-cps signal on the base of Q20, transistor Q20 will conduct current from emitter to collector and charge capacitor C77 until either phase 1 of the 110-CPS signal reverses or the 110-cps variable phase signal changes phase. During the charging cycle, the emitter-to-collector resistance of Q20 is low, and the current flowing from negative (ground) to positive

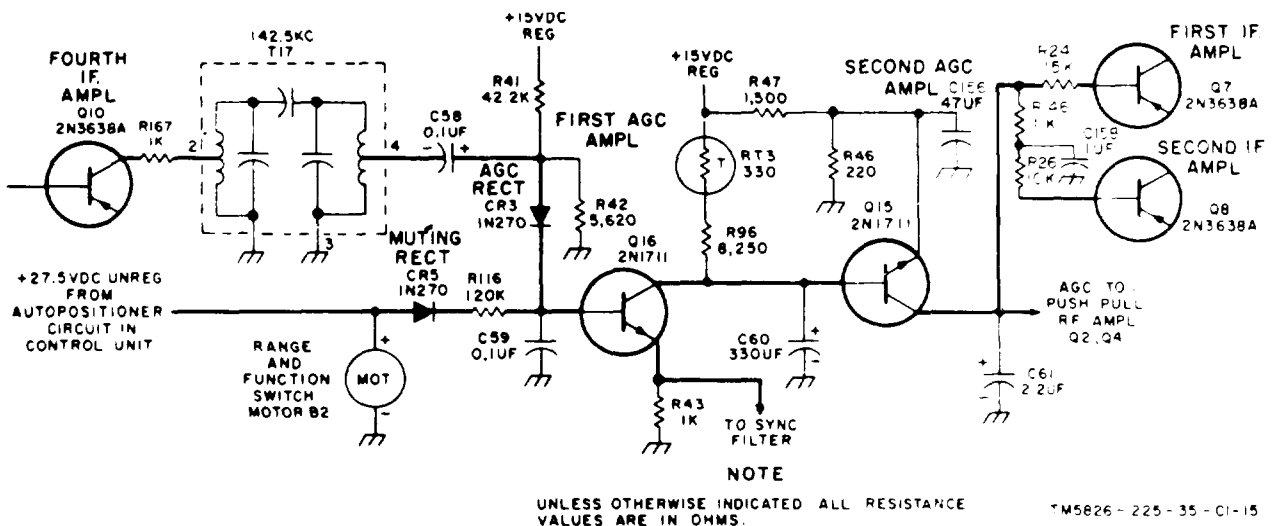

Figure 1-8. Receiver agc and muting circuit, schematic diagram.

causes the collector-to-capacitor junction connection to swing negatives at the same potential as capacitor C77 charges up to.

d. In the half cycle where the base of Q20 is negative, the emitter-to-collector resistance of Q20 is high. The collector and signal ends of capacitor C77 are negative, but the capacitor cannot discharge through the high resistance to ground. After several charging cycles, capacitor C77 is fully charged and the resistance through C77 and Q20 to ground is then high to 110 cps: When the base of Q20 is negative, the base of Q19 is positive. The emitter-to-collector resistance of Q19 is low when the 110-cps signal end of capacitor C76 is negative, permitting C76 to charge from negative to positive through Q19. Under this condition, the collector-to-capacitor junction of Q19 assumes a positive potential. After capacitors C76 and C77 are charged, the

synchronous filter presents a high resistance to ground for the 110-cps variable phase signal derived from the balanced modulator.

e. Assume that a 220-cps audio signal and 110-cps variable phase signal are both applied to capacitors C76 and C77. The phase condition of signals will be such that transistor Q19 will present a low resistance to ground for a full half cycle of the 220-cps signal with Q20 presenting a high resistance to ground for 110 cps. Adding the positive half cycles of the 220-cps and 110-cps signals will result in a charging voltage greater than capacitor C76 was originally charged to. The partial discharge of capacitor C76 through Q19 to ground will cause the collector of Q19 to swing negative. When the negative half cycle of the 220-cps signal subtracts from the positive half

cycle of the variable phase 110-cps signal, capacitor C76 will lose some of its original charge. The charge acquired by capacitor C76 at the start and end of any complete cycle of the 220-cps signal will remain the same, because the charging voltage will increase for a positive half cycle and decrease for the negative half cycle. Capacitor C76 and transistor Q19 presents a low impedance to ground for 220 cps because current constantly flows through C76 and Q19. During the negative cycle of the 110-cps variable phase signal, Q19 will present a high resistance to ground and Q20 a low resistance. The synchronous filter presents a low resistance to ground for any frequency above or below 110 cps while presenting a high impedance to 110 cps. As the undesired frequency approaches 110 cps, the synchronous filter becomes less effective.

1-18. Resolver Servo Amplifiers
(fig. 5-9)

a. Servo amplifiers Q17, Q18, Q24, and Q25, supplying power to servo motor B5, receives the 110-cps variable phase modulation envelope originally developed in the balanced modulator (para 1-7) as a result of modulating the resolver RF carrier output signal with 110 cps.

The phase and magnitude of the 110-cps signal is an exact replica of variations in phase and signal output of the resolver, which in turn depends on the location of a radio station and whether the resolver rotor apparent null is either to the right or left of the loop antenna rf signal source. As servo motor B5 rotates, resolver B3 is driven toward a null; and as the resolver rotor approaches null, the amplitude of rotor RF output signal and percentage of 110-cps modulation developed in the balanced modulator is reduced, slowing down motor B5. When null is reached, the resolver RF output signal and 110-cps modulation, drops to a minimum and servo motor B5 stops rotation. The resolver rotor null is then facing the radio station.

b. In figure 5-9, the 110-cps variable phase signal applied to the base of first servo amplifier Q17 will start at zero time increasing in amplitude in a positive direction for a radio station from 0 to 90 degrees to the right of resolver null and decrease in amplitude from 90 to 180 degrees. For a radio station to the left of resolver null from 180 to 360 degrees, the 110-cps signal will start at zero time (180 degrees) increasing and decreasing in am-

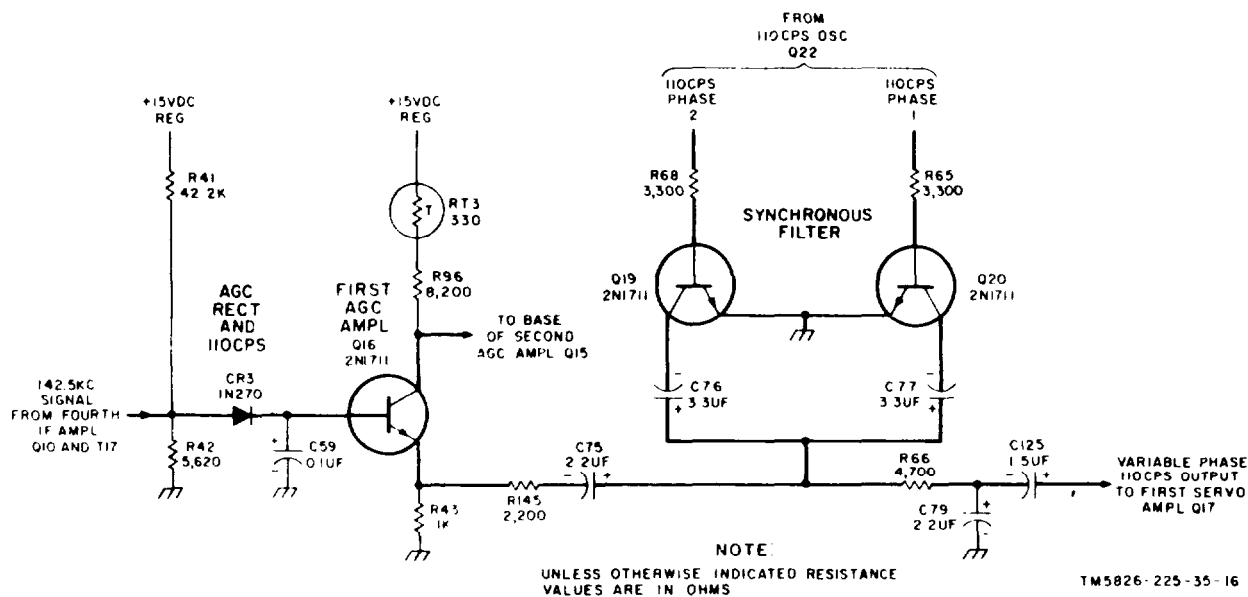

Figure 1-9. Synchronous filter, schematic diagram.

plitude in a negative direction. The phase of the signal follows the angular direction of a radio station.

c. Transistor Q17 receives emitter bias through resistor R129 and base bias through voltage divider R67 and R69. The 110-cps signal appearing on the collector of Q17, 180 degrees out of phase with that appearing on the base, is applied to second servo amplifier Q18 through phase shifter R130 and C80. Resistor R130 and capacitor C140 act as a low-pass filter. In adf operating mode, emitter and base bias voltages for Q18 are supplied through rear switch wafer S1-K. In either loop or antenna operating mode, base and emitter voltages are removed and no signal passes through Q18.

d. The 180-degree phase shifted signal on the collector of Q18 appears in the same phase on the base of one NPN transistor comprising one half of the push-pull servo amplifier, and in opposite phase on the other NPN transistor. Actually, the original 110-cps input signal of Q17 is shifted in phase by 90 degrees through T18 and other circuit components. The collectors of Q24 and Q25 are coupled to servo motor B5 through the center-tapped control-phase winding. A fixed phase 110-cps voltage is applied to the reference phase winding. Capacitor C68 shifts the phase of this voltage approximately 90 degrees. If the voltage phase on the control winding of B5 lags the reference voltage by 90 degrees, servo motor B5 will run in a counterclockwise direction. Conversely, if the phase of control voltage leads the reference voltage by 90 degrees, B5 will run in a clockwise direction. When a positive going 110-cps signal appears on the base of Q24, Q25 will receive a negative going signal. Transistor Q25 will then be cut off with Q24 conducting current through the control winding of motor B5, causing it to run in one direction. Reversing the phase of signals on Q24 and Q25 will run B5 in the opposite direction. Capacitor C69 tunes the control winding of motor B5 to 110 cps.

e. In both adf and loop operating modes, base and collector voltages for Q24 and Q25 are supplied through front switch wafer S1-K. In antenna operating mode, these voltages are removed. In loop mode (manual direction finding), switch wafer S1-L grounds one end

of the primary winding of T18. The other end of the primary winding of T18 is connected to the control unit loop switch. Positioning the loop switch to the left or right, applies either one of two 110-cps signals 180 degrees out of phase with each other to the primary of T18. A 110-cps signal of the proper phase is amplified by either Q24 or Q25 and runs servo motor B5 in the direction desired. Servo motor B5 is geared to resolver B3 and synchro control transmitter B4 through two gear trains. Synchro B4 follows resolver B3 and transmits bearing data to a synchro receiver type of bearing indicator in the aircraft. The rotor winding of synchro B4 receives 26-volts, 400-cycle ac from a de-to-ac inverter located in the receiver mount. The Radio Receiver R-1391/ARN-83, CPN 522-2587-015, utilizes an ADF HUNT CONTROL R131 in the loop servo amplifier Q17 output circuit. The control is used to adjust the amount of ADF needle activity (fluctuation about the actual bearing indication).

1-19. 110-cps Oscillator and Amplifier (fig. 1-10)

u. The 110-CPS oscillator Q22 supplies two separate phases of 110-cps signals for the 110-cps synchronous filter (para 1-17) and for using the control unit loop switch to manually rotate the receiver in loop mode (para 1-18). The 110-CPS amplifier Q23 provides single-phase, 110-CPS voltage for energizing the reference phase winding of resolver servo motor B5 (fig. 5-9).

b. Transistor oscillator Q22 is a modified Hartley oscillator. The feedback necessary to sustain oscillation is established from collector to base through impedance network L32, C151, and C153. The grounded center-tapped inductor L32 provides a 180-degree phase shift in collector output signal at the 110-CPS resonant frequency established by the parallel resonant tuned circuit of L32, C151, and C153. The 110-cps signal fed back to the base of Q22 through C9 and L24 is of the proper phase to cause oscillation. The 110-CPS oscillator operates in adf and loops modes only. In antenna mode, rear switch wafer S1-K removes emitter and base bias voltages. The 110-cps collector output signal of Q22 is amplified by 110-cps amplifier Q23 to supply sufficient current for

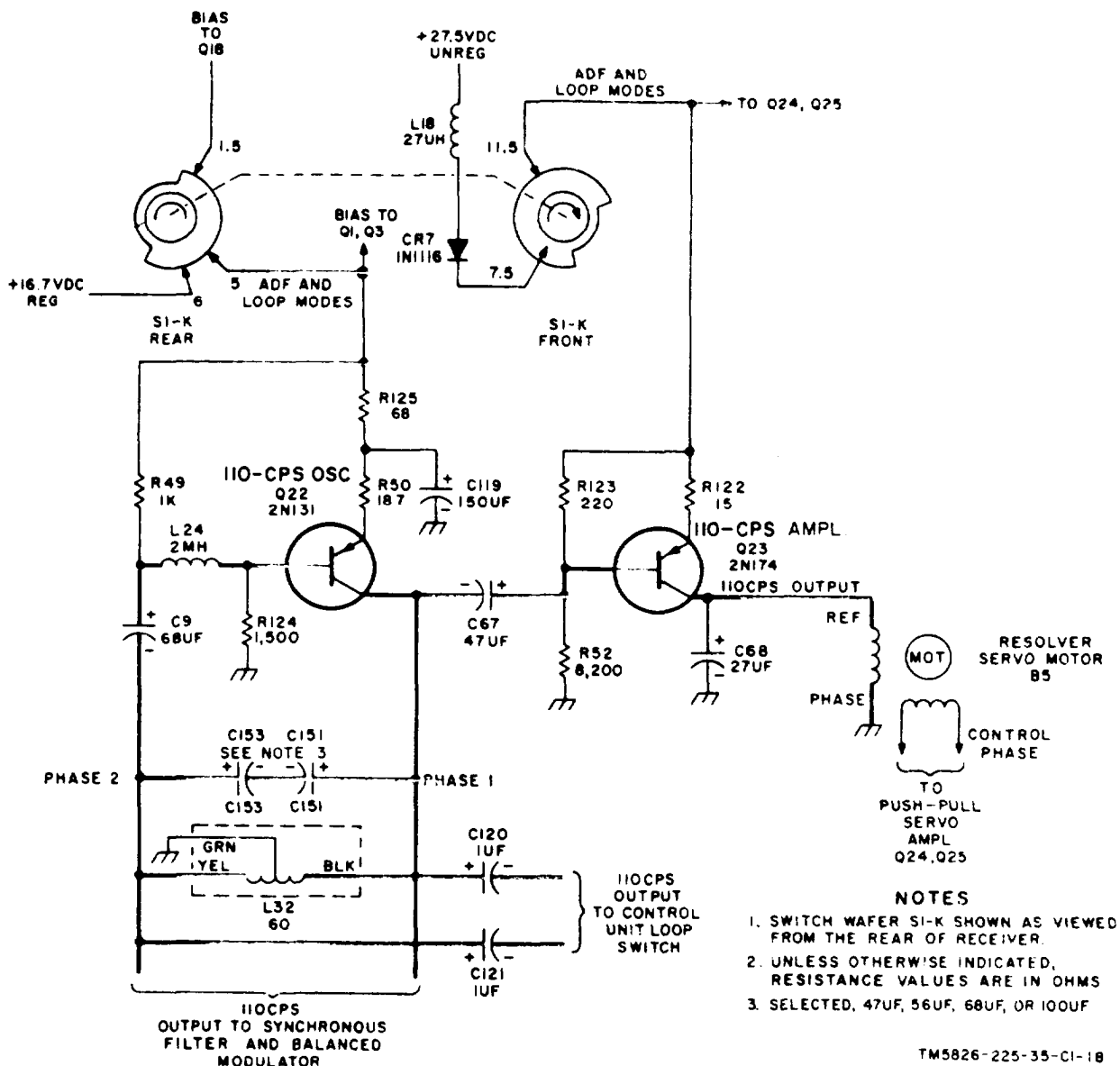

Figure 1-10. 110-cps oscillator and amplifier,

energizing the reference phase winding of resolver servomotor B5. Front switch wafer S1-K removes bias voltages in antenna operating mode.

1-20. Tuning Servoamplifiers (fig. 1-11)

a. The receiver is remotely tuned over each

frequency range by a five-section variable capacitor positioned by a closed-loop servo-system receiving synchro signals from the control unit. The control unit TUNE knob is geared to a synchro control transmitter whose rotor winding is excited by a 26-volt, 400-cps source. The synchro stator windings are connected to the stator windings of tuning syn-

chro B1. As the control unit synchro rotor is positioned, it couples and decouples one or more stator windings inducing magnetic fields that, when added algebraically, produce a resultant magnetic field in synchro B1 with the same phase and direction as developed in the control unit synchro rotor. The stator of synchro control transformer B1 is the primary and the rotor is the secondary. The rotor of synchro B1 is driven by motor generator set MG1. Therefore the rotor output signal is proportional to the angular difference between actual rotor position and electrical zero or null. There are two nulls spaced 180° apart and as the rotor turns past each null, the rotor output signal will change phase.

b. Positive- and negative-going rotor output signals of high amplitudes are limited by diodes CR6 and CR9. The amplitude limiter does not conduct on low amplitude signals. This insures maximum amplifier input sensitivity at the low voltage null points while preventing high amplitude signals (away from null) from overdriving and servoamplifier. The limited signal is amplified by transistors Q26 and Q27 and applied to Q28 and Q29 through T19.

c. The signals on terminals 3 and 5 of the transformer T19 secondary winding are in phase. If a positive-going, 400-cps signal appears on the collector of Q27, negative-going signals will appear on terminals 3 and 5. The signals on terminals 3 and 6 are of opposite phase. During the half cycle that the base of transistor Q28 is forward biased into conduction, the base of Q29 is reverse biased into nonconduction. Transistor Q28 then presents a low resistance from emitter to collector, while Q29 presents a high resistance. Because of the negative signal on terminal 5 of T19, the junction of Q29 collector and resistor R62 are near ground potential. Transistor Q28 conducts current through the control phase winding of the servomotor, capacitor C74, and resistor R62 causing motor rotation. During the half cycle that Q28 receives a negative-going signal, Q29 receives a positive-going signal. Due to the totem pole configuration of Q28 and Q29, the collector of Q29 will re-

ceive sufficient dc voltage through the internal resistance of Q28. The current through Q29 will run the motor in the opposite direction.

d. The phase of the voltage in the motor control winding either leads or lags the reference-phase voltage by 90° . The direction of servomotor rotation (and rotor of B1), changes as the control-phase voltage shifts from a leading phase to a lagging phase relative to the reference phase voltage. The change in the direction of motor rotation and change in phase occurs as the synchro rotor turns past null. Due to the followup system of gears between the servomotor and synchro, the synchro rotor will be driven until the angular difference between its rotor null position and orientation of magnetic field in the stator winding becomes zero. This will occur when both the control unit and receiver tuning synchro rotors are at the same position. To prevent hunting about the null positions, a tachometer generator feedback signal, which is proportional to servomotor speed, is applied through variable resistor R111 to the base of Q26. This feedback voltage is always 180° out-of-phase with the amplifier input signal. Diode CR7 protects Q28 and Q29 from a reverse in aircraft dc voltage source polarity. Variable capacitor C1 and synchro B1 are coupled through a one-to-one ratio gear train.

1-21. Voltage Regulator (fig. 1-12)

a. The voltage regulator, in addition to suppressing line voltage transients from the aircraft dc power source, provides correct operating voltages to all transistors requiring these voltages. Regulation is accomplished with a PNP transistor, and Zener diodes.

b. Transistor Q30 operates as a series regulator and transistor Q31 as a current control amplifier for Q30. The voltage drop through series regulator Q30 is a function of its internal resistance which increases with reverse base bias and decreases with forward base bias. The collector and emitter of transistor Q31 are connected in parallel with the base and collector of Q30. Zener diode CR4 provides

a forward base bias reference voltage for Q31 approximately 1 volt higher than its emitter voltage. If the nominal 16.7-volt output of series regulator Q30 tends to rise, the emitter bias of Q31 will also increase; which, in turn, will increase the positive collector voltage of Q31 and apply a higher reverse base bias on transistor Q30. The internal resistance of Q30 will then increase, lowering the collector output voltage. If the regulated output voltage drops, the emitter bias of Q31 will be less than

the forward base bias, causing the positive collector voltage of Q31 to become less positive (more negative). The base of PNP transistor Q30 will be forward-biased and its internal resistance will also decrease, causing an increase in collector output voltage. Zener diode CR11 regulates the 15-volt dc output. A potentiometer across the regulated 15-volt dc output provides control for first resolver servoamplifier Q17 bias voltage. Diode CR7 protects the power supply from reversed input voltage polarity.

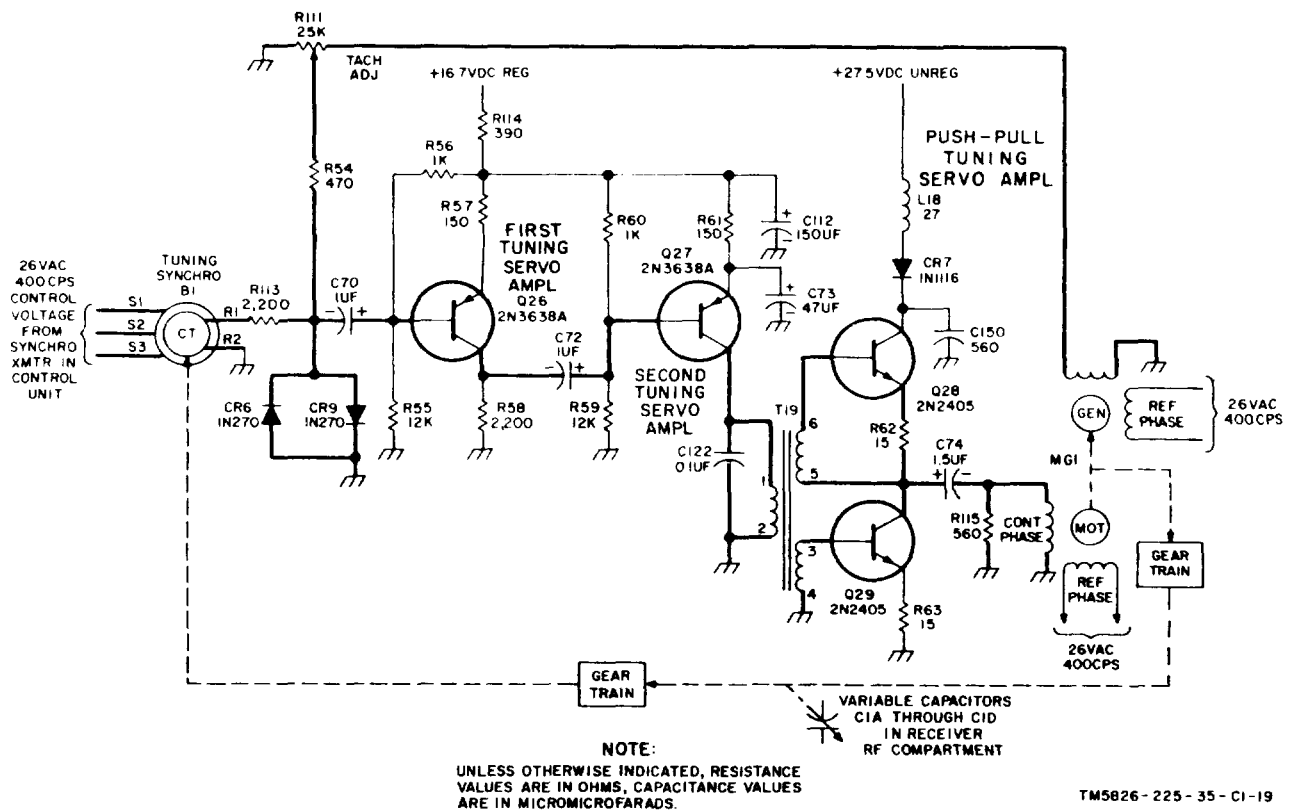
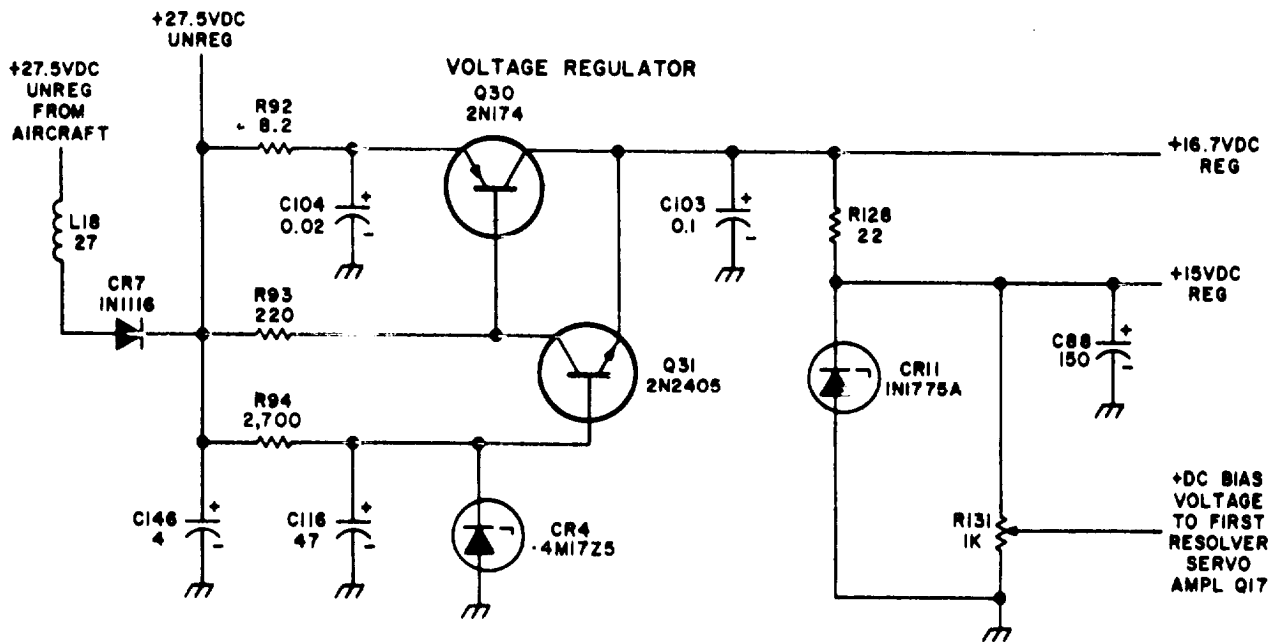

Figure 1-11. Tuning servoamplifiers, schematic diagram.



NOTE:
UNLESS OTHERWISE INDICATED, RESISTANCE VALUES ARE IN OHMS,
CAPACITANCE VALUES ARE IN MICROFARADS,
INDUCTANCE VALUES ARE IN MICROHENRYS.

TM 5826-225-35-C1-20

Figure 1-12. Regulated dc power supply, schematic diagram.

Section III. DETAILED FUNCTIONING OF ADDITIONAL EQUIPMENTS

1-22. General

Radio Receiver R-1391/ARN-83 is the main operational unit of Direction Finder Set AN/ARN-83. Detailed functioning of the receiver is covered in section II of this chapter. The remaining components of Direction Finder Set AN/ARN-83 are Inverter Power, Static CV-2128/ARN-83, Mounting MT-3605/ARN-83, Antenna AS-1863/ARN-83; and Direction Finder Control C-6899/ARN-83. For detailed functioning of these components (except Mounting MT-3605/ARN-83), refer to paragraphs 1-23, 1-24, and 1-25. Mounting MT-

inverter), therefore is not included. Figure 1-16 is an interconnecting cabling diagram of Direction Finder Set AN/ARN-83.

1-23. Inverter, Power, Static CV-2128/ARN-83 (fig. 1-13)

The inverter circuit changes 27.5 volts dc to 26 volts, 400 cps ac for motor generator MG1 and synchro B4 in the receiver and B301 in the control unit. The inverter comprises 400-cps oscillator Q1 coupled to a push-pull amplifier

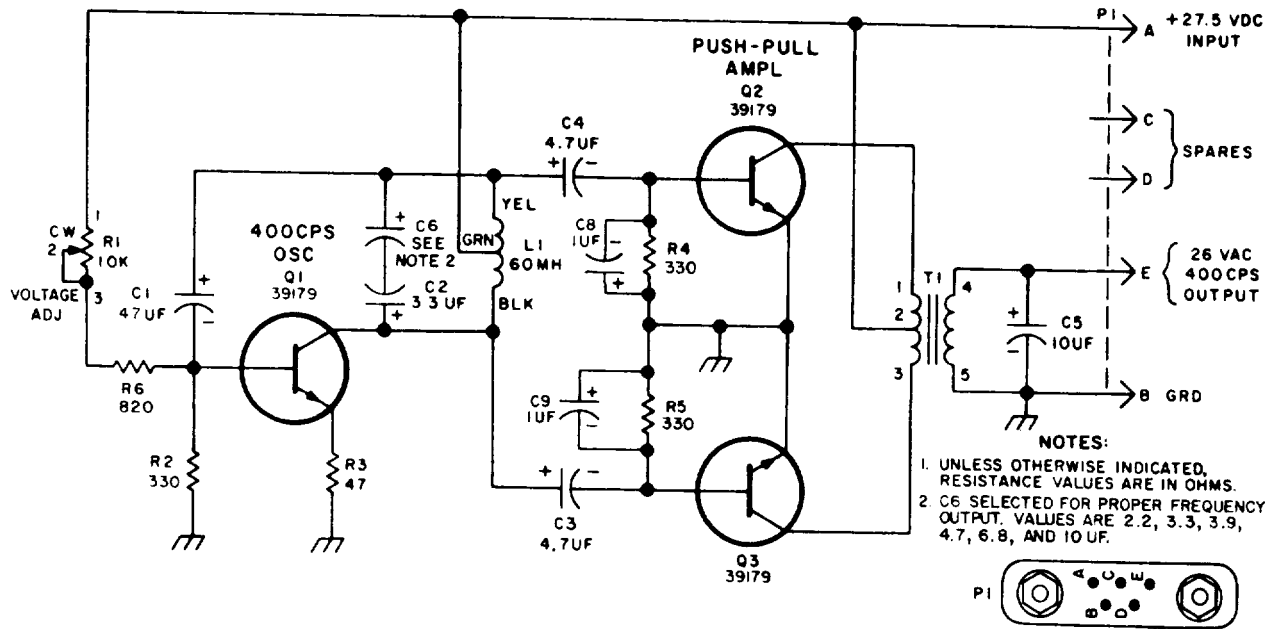
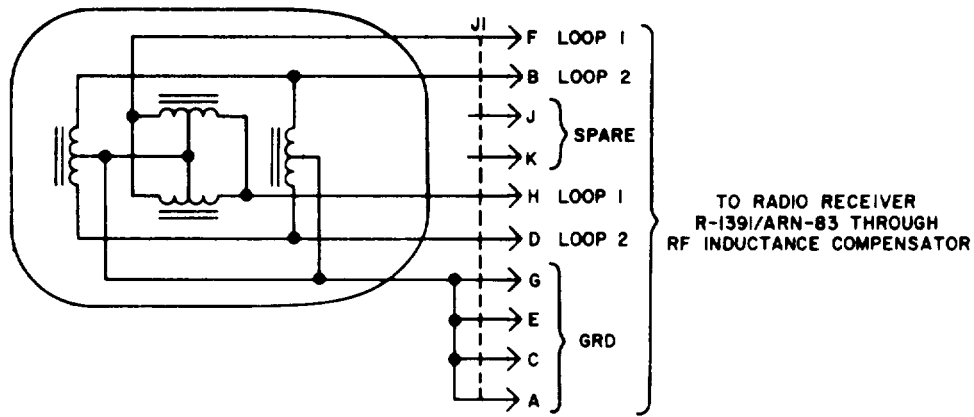

Figure 1-13. Inverter, Power, Static CV-2128/ARN-83, schematic diagram.

TM5826-225-35-CI-21
 3. REVISION HISTORY

ITEM	CHANGE	AT CI NUMBER
R6	2700Ω TO 1800Ω	69123
R4, R5	820Ω TO 330Ω	73395
R7, R8	1Ω RESISTOR ADDED	73395
R6	1800Ω TO 820Ω	73395



1. LOOP 1 PARALLEL TO LONGITUDINAL AXIS OF AIRCRAFT.
LOOP 2 PERPENDICULAR TO LOOP 1.
2. DETAIL OF JI.

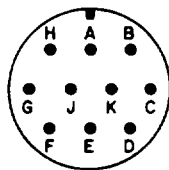

TM5826-225-35-33

Figure 1-14. Antenna AS-1863/ARN-83, schematic diagram.

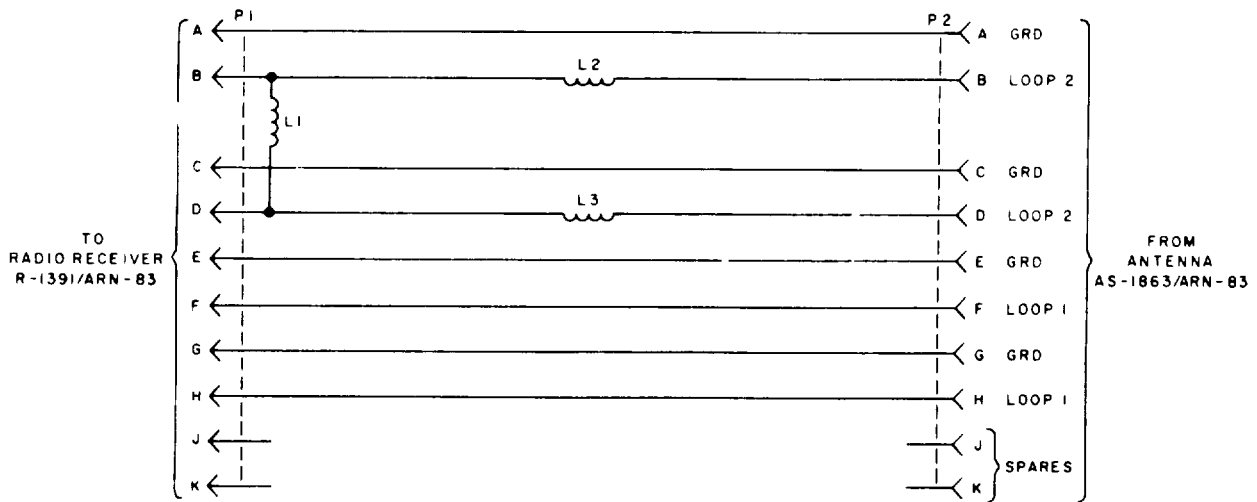

NOTE:

1. COMPONENT VALUES VARY WITH INSTALLATION.
2. DETAIL OF CONNECTORS.

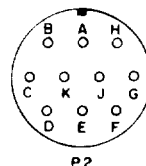
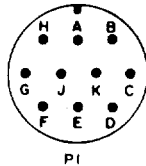

TM5826-225-35-40

Figure 1-15. Typical RF inductance compensator, schematic diagram.

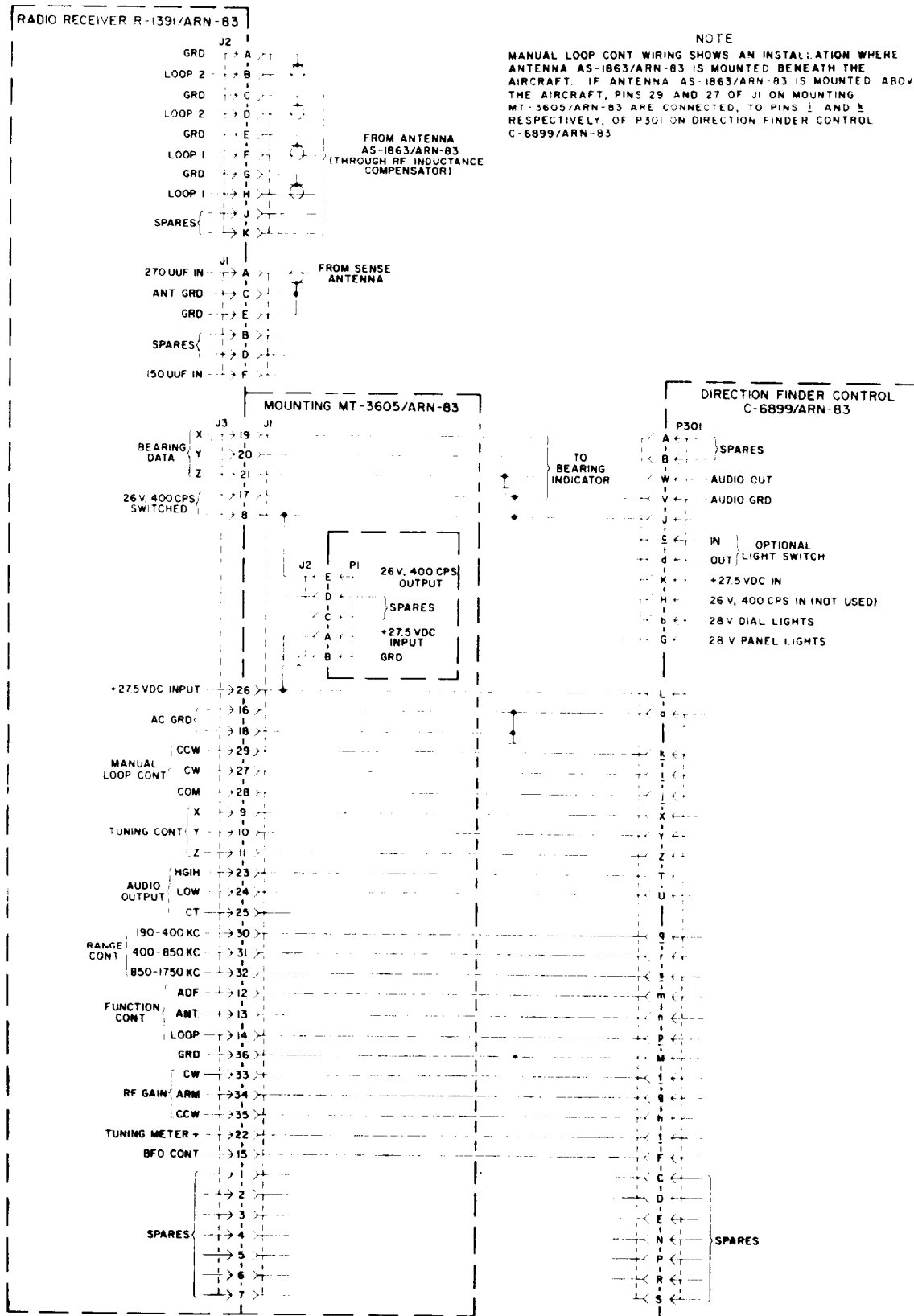

NOTE
 MANUAL LOOP CONT WIRING SHOWS AN INSTALLATION WHERE ANTENNA AS-1863/ARN-83 IS MOUNTED BENEATH THE AIRCRAFT. IF ANTENNA AS-1863/ARN-83 IS MOUNTED ABOVE THE AIRCRAFT, PINS 29 AND 27 OF J1 ON MOUNTING MT-3605/ARN-83 ARE CONNECTED TO PINS 1 AND 2 RESPECTIVELY, OF P301 ON DIRECTION FINDER CONTROL C-6899/ARN-83

Figure 1-16. Direction Finder Set, AN/ARN-83, interconnecting cabling diagram.

TM5826-225-35-41

consisting of Q2 and Q3. Transistor Q1 oscillates with positive collector-to-base feedback introduced by the parallel resonant tank circuit comprising capacitors C20 and C6 and center-tapped inductor L1. At the resonant frequency of 400 cps, the tank circuit presents an impedance that applies a signal to the base of Q1 180° out-of-phase with the collector output signal. A signal passing from the base to the collector is shifted 180 degrees and, adding the tank circuit 180° phase shift, results in positive feedback to the base of Q1. The two opposite phases of the 400-cps signals are amplified by push-pull amplifier Q2 and Q3 and applied to transformer T1. When transistor Q2 receives a positive-going oscillator signal, Q3 receives a negative-going signal. During the next half cycle, signal polarities are exchanged. The secondary of T1 steps up the ac signal to 26 volts. The frequency of oscillation is adjusted by variable resistor R1 which supplies base voltage to Q1.

1 -24, Antenna AS-1863/ARN-83
(fig. 1-14)

Antenna AS-1863/ARN-83 consists basically of four ferrite-cored coils, two of which are

parallel to the longitudinal axis of the aircraft and two are perpendicular to this line. Each set of physically parallel coils is connected in parallel to provide maximum gain. The antenna provides the basic information necessary to determine the direction of the received signals. Refer to paragraph 1-5 for a discussion on how this is accomplished. An RF inductance compensator is required between the loop antenna and the receiver to compensate for the deflection of arriving radio signals by the fuselage of the aircraft. For this reason the RF inductance compensator is selected during installation. Figure 1-15 is a schematic diagram for a typical RF inductance compensator.

1-25. Direction Finder Control
C-6899/ARN-83

Detailed functioning of the control unit is contained in section IV of this chapter. Section IV describes interunit circuit functioning. Figure 5-11 is the schematic diagram for the control unit.

Section IV. INTERUNIT CIRCUIT FUNCTIONING

1-26. General

Interunit functions are included in this section to provide an understanding of certain interrelations between the control unit and receiver in various types of operation. Such knowledge will enable maintenance personnel, when troubleshooting, to sectionalize troubles to a defective unit and, in some cases, to localize trouble to a defective part within a unit. Circuit functioning of components in the control unit and receiver is discussed only where individual circuits are interconnected in a common circuit,

1-27. Function and Frequency Range Selection

(fig. 5-12)

a. General. Function and frequency range

selection in the receiver is accomplished through the interunit autopositioner circuit illustrated in figure 5-12. The function and range-switching mechanism in the receiver consists of a motor-driven, multisection switch combining both function and range selection into one ganged switch. Since the control unit function switch has three operating mode positions (ADF, ANT, and LOOP) requiring three frequency range positions of range switch S304 for each operating mode, it requires nine positions of the receiver motor-driven switch to select all operating modes and frequency ranges. In the receiver, switch wafers S1-M through S1-R are 12-position switches having nine effective switch positions over three sectors or quadrants of the switches (leaving three blank positions). Each switch wafer is divided into three equal areas or sectors with

each third sector representing three frequency ranges in a particular operating mode. There is a blank position between each operating mode representing no function or mode. It should be noted that switches S1-M, S302, and S304, have half positions as well as full positions.

b. Function Selection. Switch S1-M, a combination frequency range and function switch, is a position-seeking switch, seeking the positions at which the control unit function and range switches are set. The wide, projecting area of rear switch wafer S1-M, covers four positions (representing three ranges and one blank position) for each function. This projecting area will be positioned within the appropriate switch quadrant depending on where the control unit function switch is positioned. When function switch S302 is set to the ADF position, +27.5 volts is applied through contacts 9.5 and 11 of rear switch wafer S302B and contacts 11 and 9 or 10 of front switch wafer S302B. This voltage is connected to motor B2 through contacts 2 or 6 and 5 of rear switch wafer S1-M, causing motor B2 to run. When motor B2 rotates switch S1 clockwise until contacts 2 and 6 of rear switch wafer S1-M are open (the position shown in fig. 5-12) it is positioned in the adf operating sector activating the circuits of this mode (represented by the open wire connection of front switch wafer S302B). Motor B2 is stopped through the braking action of a ground supplied by resistor R308, through front switch wafer S304 and front switch wafer S1-M. Setting function switch S302 to the ANT position, applies +27.5 volts to two of the operating mode wires (adf and loop) while leaving the third mode wire (antenna) open. The voltage applied to B2 through rear switch wafer S1-M rotates S1 to the antenna mode sector disconnecting all sources of +27.5 volts. Setting the function switch to loop position, applies motor operating voltage over the adf and antenna mode circuits while leaving the third circuit (loop) open and accomplishing the same results as for the other operating modes.

c. Range Selection. Setting range switch S304 to the 400- to 850-kc range, applies +27.5

volts over the 190- to 400-kc and 850- to 1750-kc circuits while leaving the 400- to 850-kc circuit open. The voltage applied over the 190- to 400-kc circuit and through front switch wafer S1-M to motor B2 rotates switch S1 clockwise. When the switch rotor reaches contact 3.5 (half position) motor B2 will stop rotation because of the absence of voltage on the 400- to 850-kc circuit (removed by switch S304). During motor and switch rotation, movement of the rotor tab of front wafer S1-M from contact 2.5 to contact 3.5 meets a position where no voltage is applied to motor B2. To prevent the motor from stopping when switching frequency ranges, voltage is supplied through three small rotor tabs on rear switch wafer S1-M. In a similar manner, contact 1.5 of the front switch wafer supplies motor voltage for function switching when the rear switch wafer of S1-M rotates to a blank position. Selecting any frequency range always applies +27.5 volts over two circuits, while leaving the desired circuit open. The positive side of motor B2 is connected to a muting circuit which silences the receiver during function and range switching. All control signals between the control unit and receiver pass through connections in the receiver mount and airframe cabling.

1-28. Receiver Tuning (fig. 5-13)

The receiver is tuned over each frequency range by multisectioned variable capacitor C1 which is positioned by a servomechanism remotely controlled from the control unit TUNE control. When control unit function switch S302 is moved from OFF to ADF, ANT, or LOOP position, a 26-volt 400-cps source is applied to the rotor winding of tuning synchro control transmitter B301 and the reference phase windings of motor generator MG1. The rotor of synchro B301 is geared to the TUNE control and rotating the rotor of B301 induces currents into the stator windings of B301, which result in magnetic fields of the same phase and direction in the stator windings of B1. The rotor of synchro B1 then follows the rotor of synchro B301 for any setting of the TUNE control. The 26-volt, 400-cps source required for synchro

excitation and MC1, is derived from a dc-to-ac voltage inverter located in the receiver mount. All electrical connections between the control unit and receiver are made through the receiver mount and airframe cabling.

1-29. Manual Loop Control (fig. 5-14)

a. The direction finder set uses a servo-driven resolver functioning as a goniometer instead of the conventional rotating loop antenna used in some adf systems. A goniometer generates a rotating figure-eight loop antenna pattern identical to that produced by a rotating loop antenna. The aircraft bearing indicator follows the goniometer rotor position and indicates the azimuth or direction in which a loop antenna would point to if it could rotate. A loop switch on the control unit enables the operator to position the goniometer and bearing indicator manually for either manual direction finding or to check the precision of bearing indication in adf operating mode. This is accomplished by observing the precision in which the bearing indicator pointer returns to its original bearing indication after the goniometer rotates past a null position. When manual direction finding mode is desired, the operator sets the control unit function switch to LOOP position.

b. In figure 5-14, two phases of 110-CPS signals derived from the receiver 110-CPS oscillator Q22 are applied to LOOP switch S303. Switch S303 has two positions right or left, with spring return to its center or grounded position. In the first position left or right, the magnitude of the 110-CPS signals are attenuated by resistors R306 and R307. These two switch positions are slow speed positions, providing a slower speed of goniometer rotation than the second switch position left or right. When switch S303 is in its center position, the servoamplifier manual loop control signal path is grounded, preventing spurious signals from affecting adf operation. Positioning switch S303 either right or left applies either phase 1 or phase 2 (180° out-of-phase with phase 1) to servoamplifier input transformer T18. When the control unit function switch is set to LOOP position, switch S1-L grounds terminal 1 of

transformer T18 and the collector of second resolver servoamplifier Q18. Terminal 2 of T18 is then used as the servoamplifier input Phase 1 of the 110-cps signal applied to push-pull resolver servoamplifier Q24 and Q25 causes clockwise rotation (to right) of resolver B3 functioning as a goniometer, and phase 2 of the 110-CPS signal causes a counterclockwise rotation (to left). Synchro transmitter B4 and the aircraft bearing indicator follows resolver B3.

c. When manual goniometer rotation is desired while operating in adf mode, the control unit function switch is set to ADF position. Switch S1-L, operating through the control unit and receiver autopositioner circuit (para 1-27), removes the ground from the collector of Q18 (fig. 5-14). Normally in adf operation, the collector voltage and current path of Q18 is through grounded LOOP switch S303 and the primary winding of T18. Positioning LOOP switch S303 either right or left opens the collector circuit and thus disables adf operation. The resistance of R133 is sufficient to prevent Q18 from receiving collector voltage while providing a ground return for T18. These circumstances permit manual goniometer rotation in adf operating mode. All electrical connections between the control unit and receiver are made through the receiver mount and airframe cabling. For resolver servo amplifier circuit details refer to paragraph 1-18.

1-30. Manual Audio and RF Gain Control

When the direction finder set is operated as an automatic direction finder (adf), audio gain is controlled by dual gain potentiometers in the control unit. The RF gain cannot be varied manually. In antenna and manual direction finding modes, RF gain is controlled by a potentiometer ganged to the audio gain potentiometers. Audio gain cannot be varied.

a. *Manual Audio Gain Circuit (fig. 5-15).* The receiver audio output from transformer T20 is applied through connections in the receiver mount and airframe cabling to control unit function switch S302, which is shown in ADF position. Variable resistors R301-A and R301-B, in conjunction with resistors R304

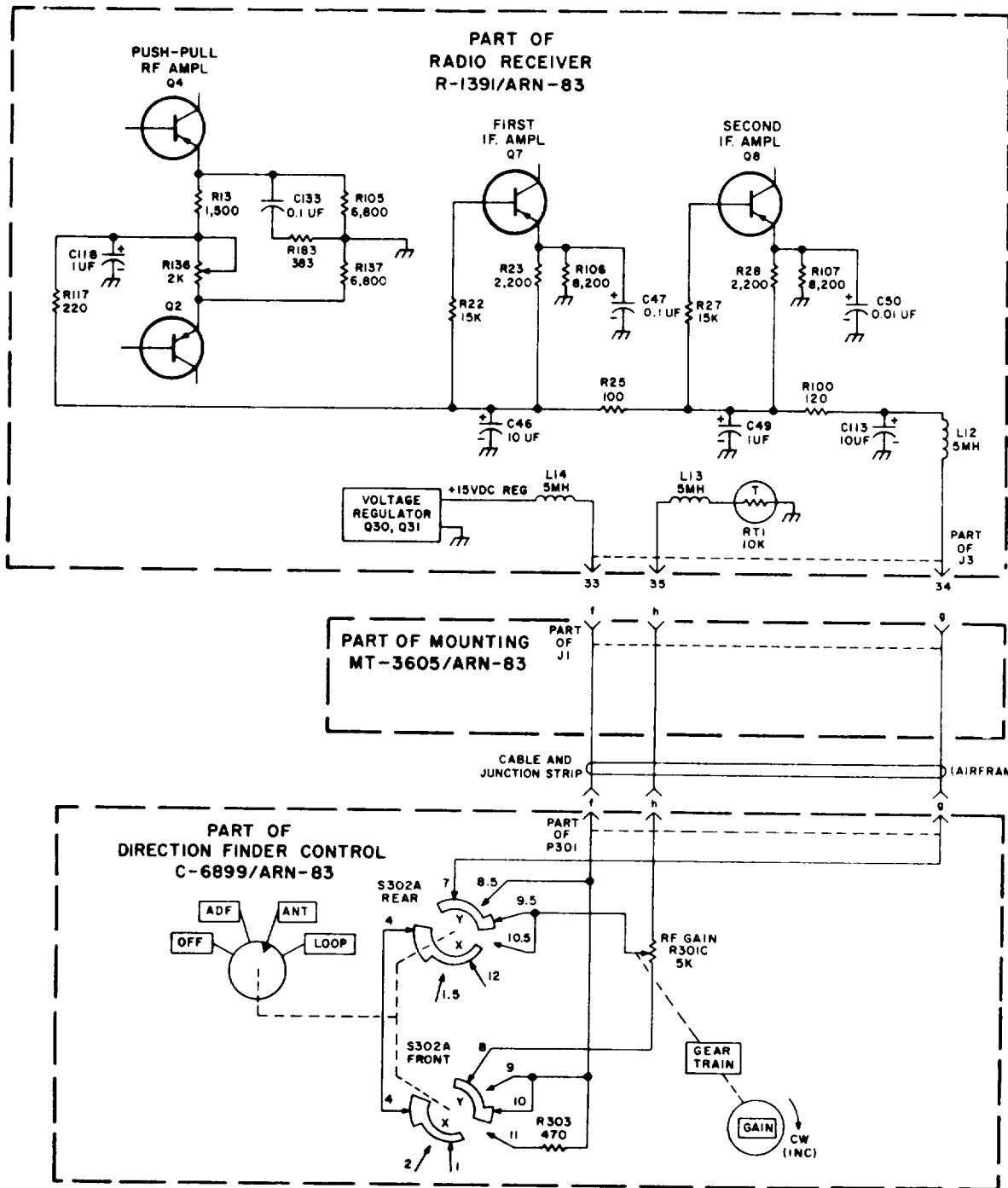

- NOTES:
1. UNLESS OTHERWISE INDICATED, RESISTANCE VALUES ARE IN OHMS, INDUCTANCE VALUES ARE IN MICROHENRYS.
 2. SWITCH S302 SHOWN AS VIEWED FROM SIDE FACING CONTROL KNOB.
 3. RF GAIN CONTROL R301C GANGED WITH AUDIO ATTENUATORS R301A, R301B.
 4.  INDICATES EQUIPMENT MARKING.

TM5826-225-35-CI-26

Figure 1-17. Manual RF gain control system, schematic diagram.

and R305, forms a bridged-T attenuator which presents a constant 600-ohm output impedance to the aircraft interphone system. This impedance value matches the aircraft voice range filter network impedance. When function switch S302 is set to either ANT or LOOP, the variable resistors are shorted out by contacts 4 on the front and rear wafers of S302-A. In LOOP operating mode, switch wafer S1-L, connects capacitor C11 in parallel with terminals 3 and 4 of output transformer T20. This reduces the audio output level so that sharper aural nulls may be obtained during manual direction finding. It should be noted that turning the GAIN control clockwise rotates R301 counterclockwise.

b. *Manual RF Gain Control Circuit (fig. 1-17).* In antenna and manual direction finding mode, only RF gain can be varied manually. This is accomplished by varying the bias on two IF amplifier stages and on the push-pull RF amplifier. An increase in positive bias voltage decreases gain. When function switch

S302 is set to either ANT or LOOP, +15 volts dc is attenuated by variable resistor R301-C and applied as bias voltage to transistors Q2, Q4, Q7, and Q8. The network comprising thermistor RT1 and resistor R118 stabilizes bias voltages by temperature compensation. In the LOOP position of switch S302, resistor R303 decreases RF gain to compensate for the increase in gain caused by switching out certain signal attenuating networks in the receiver RF stages during loop operation, thus, RF gain is practically the same in either antenna or loop operating modes for the same RF gain control setting. In adf mode, variable resistor R301-C is bypassed through switch S302 applying + 15-volt bias without attenuation. It should be noted that turning the GAIN control clockwise, rotates R301 counterclockwise.

1-31. Receiver Bfo Switching
(fig. 1-18)

The control unit BFO-OFF switch controls

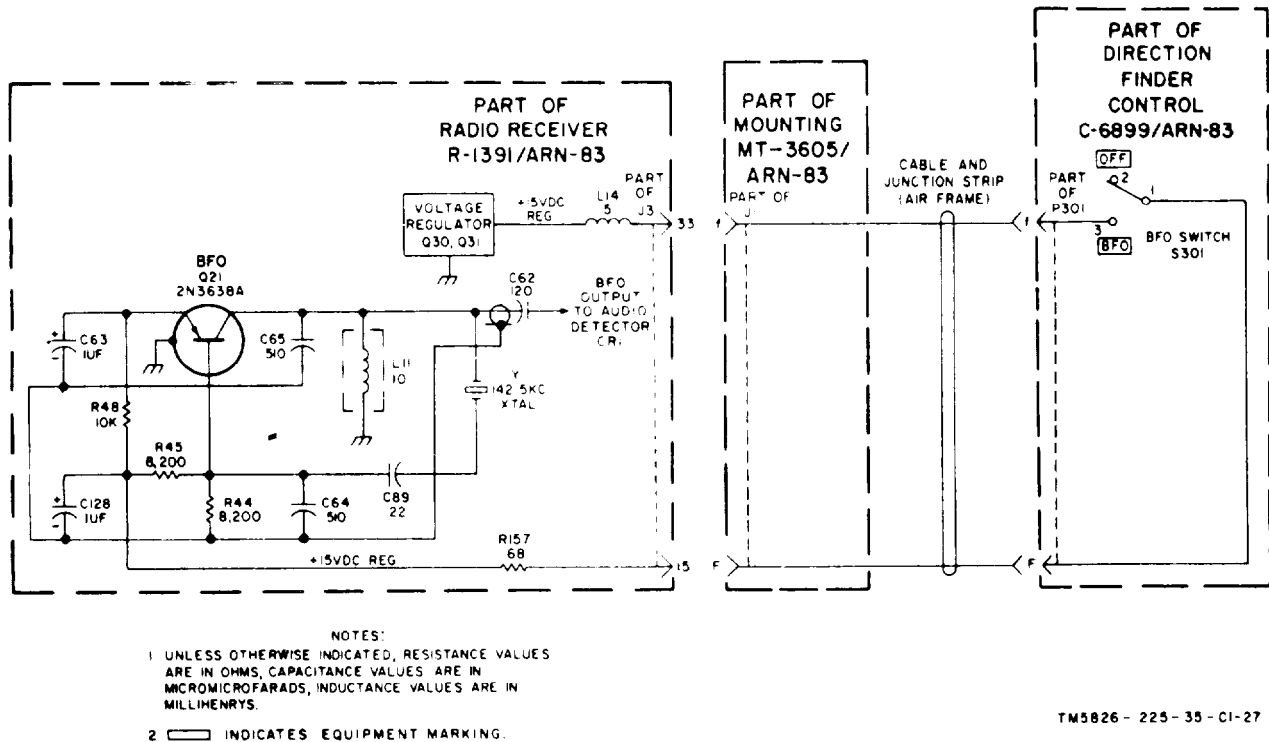

Figure 1-18. Bfo control circuit, schematic diagram.

operation of bfo Q21 by supplying or removing emitter and base bias voltages. A regulated source of + 15 volts dc is connected to one side of BFO-OFF switch S301. Setting the switch of BFO, applies proper bias voltages to Q21 causing it to oscillate. When the BFO-OFF switch is set to OFF, bias voltage is removed and transistor Q21 cannot oscillate. The bfo is used for tuning to zero beat when receiving continuous wave (cw) signals. For bfo circuit functioning, refer to paragraph 1-14.

**1-32. Receiver Tuning Meter
(fig. 1-19)**

Tuning meter M301 mounted on the control

unit front panel is a dc microammeter requiring 100 microampere of current for full-scale deflection. The negative side of M301 is grounded and the positive side is connected to the cathode of meter rectifier CR10 through a low-pass filter comprising R40, L15, C117, and C114. The current flowing through M301 is the half wave, rectified, positive cycles of signal present at the output of IF transformer T17. This current is proportional to the amplitude of IF amplifier signal and reaches maximum amplitude when the receiver is tuned to the RF carrier of a radio station. The receiver is tuned for maximum tuning meter indication.

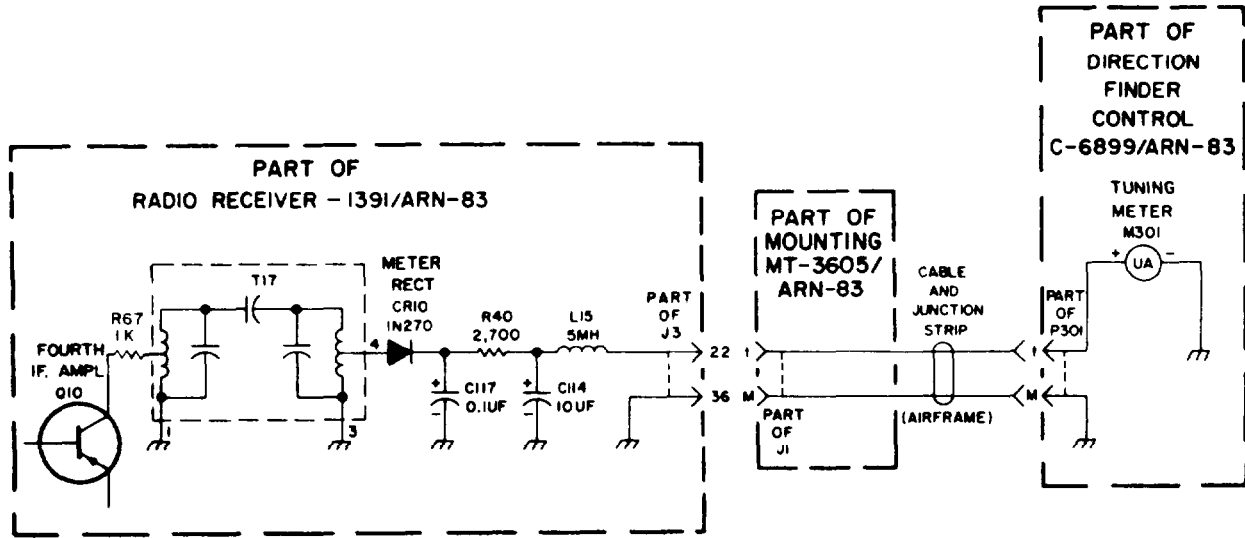

TM5826-225-35-C1-28

Figure 1-19. Receiver tuning meter, schematic diagram.

CHAPTER 2

TROUBLESHOOTING

Section 1. GENERAL TROUBLESHOOTING TECHNIQUES

2-1. General

The direct support, general support, and depot maintenance procedures in this manual supplement the procedures outlined in the operator's and organizational maintenance manual. The systematic troubleshooting procedure, which begins with the operational and sectionalization checks that can be performed at an organizational level, is carried to a higher level in this manual. Sectionalizing, localizing, and isolating techniques used in the troubleshooting procedures are more advanced.

2-2. Organization of Troubleshooting Procedures

a. *General.* The first step in servicing a malfunctioning direction finder set is to sectionalize the fault. Sectionalization means tracing the fault to a unit or circuit. The second step is to localize the fault. Localization means tracing the fault to a defective part responsible for the abnormal condition. Some faults, such as burned-out resistors, and arcing and shorted transformers or motors, can often be located by sight, smell, and hearing. The majority of fault, however, must be isolated by checking voltages and resistances.

b, Sectionalization. Listed below is a group of test arranged to reduce unnecessary work, and to aid in tracing trouble in a malfunctioning direction finder set, Direction Finder Set AN/ARN-88 consists of five units; the control unit the receiver, the mounting, the inverter, and the loop antenna. The first step is to locate the unit or units at fault by the following methods:

(1) *Visual inspection.* The purpose of visual inspection is to locate faults without testing or measuring circuit. Indications on the aircraft heading indicator and on the control unit tuning meter or other visual signs should be observed during all operating modes, and an attempt should be made to sectionalize the fault to a particular unit.

(2) *Operational tests.* Operational tests frequently indicate the general location of trouble. In many instances, the tests will help in determining the exact nature of the fault. The intermediate preventive maintenance checks and services chart (TM 11-5826-225-12) contains a list of operational checks which helps to sectionalize troubles to a unit.

c. *Localization.* After the trouble has been sectionalized (*b* above), the methods listed in (1) through (3) below will aid in localizing the trouble to a circuit, stage, or mechanical system in the suspected unit.

(1) *Troubleshooting chart.* Tuning meter and bearing indicator indications or lack of indications and operational checks provide a systematic method of localizing trouble to a circuit, stage, or mechanical system. The trouble symptoms listed in the troubleshooting charts (paras 2-5d and 2-9b) will provide additional information for localizing trouble.

- (2) *Signal substitution.* Signal substitution procedures for the receiver (para 2-6) enable the repairman to localize a trouble quickly to a receiver circuit or stage. An RF signal generator, audio oscillator, and oscilloscope are units of test equipment (para 2-3e) that may be used in signal substitution procedures. Observe the caution notice in paragraph 2-6a and follow the signal substitution procedures (para 2-6) closely so that damage to transistors may be avoided.
- (3) *Stage-gain charts.* The receiver stage-gain charts (para 2-7) will help locate difficult troubles that produce weak signals and should be used when performing the signal substitution procedures.

d. *Isolation.* After the trouble has been localized (c above), the methods in (1) through (5) below will help in isolating the trouble to a defective circuit element.

- (1) *Waveform analysis.* Voltage readings taken in some cases are difficult if not impossible to analyze because these voltages vary with circuit conditions (equipment operation). For these circuits, waveforms must be taken and compared with the waveforms provided.
- (2) *Voltage measurements.* This equipment is transistorized. When measuring voltages, use tape or sleeving (spaghetti) to insulate the entire test prod, except for the extreme tip. A momentary short circuit can ruin the transistor. For these voltage measurements, use Multitester ME-26/U (vtvm) or the equivalent.
- (3) *Resistance measurements.* To avoid transistor damage, make resistance measurements in this equipment only as necessary.

Caution: Before using an ohmmeter to test in transistor circuits, check the open circuit voltage across the ohmmeter test leads. Do not use the ohmmeter if the open circuit voltage ex-

ceeds 1.5 volt. Since the Rx1 range normally connects the ohmmeter internal battery directly across the test leads, the excessively high current (50 ma or more) may ruin some transistors in the circuit. For a safe current that will not damage transistors, use the Rx100 range of Multi meter TS-352/U.

- (4) *Test points.* All wiring in this equipment is from point-to-point. The wiring and component junction connections are supported by insulated standoff terminal studs. Any of these terminals may be used as a test point as required. No test jacks are provided. The terminal studs used for testing and troubleshooting in the receiver are shown on the main schematic diagram (fig. 5-10 or 5-10.1) as TP1, TP2, ect .
- (5) *Intermittent troubles.* In all of these tests, the possibility of intermittent troubles should not be overlooked. If present, this type of trouble may often be made to appear by tapping or jarring the equipment. Make a visual inspection of the wiring and connections.
- (6) *Resistor and capacitor color code diagrams.* Resistor and capacitor color code diagrams (figs. 4-11 and 5-1) are provided to aid maintenance personnel in determining the value, voltage rating, and tolerance of capacitors and resistors.

2-3. Test Equipment Required

The following chart lists test equipment required for troubleshooting Direction Finder Sot AN/ARN-83 and the associated technical manuals.

Caution: The receiver and inverter circuits are transistorized. Use all precautions to avoid transistor damage.

- a. Never connect test equipment (other than multimeter and vtm's) outputs directly to a transistor circuit; use a coupling capacitor.

b. Make test equipment connections with care so that shorts will not be caused by exposed test equipment connectors. Tape or sleeve (spaghetti) test prods or clips as necessary to leave as little exposed as needed to make contact to the circuit under test.

c. The aircraft 28-volt dc source (or its equivalent) normally used is recommended as the source of power when servicing this transistorized equipment. *Observe polarity.* Polarity reversal may damage the transistors or electrolytic capacitors in the circuits. This equipment requires a negative ground. If a battery eliminator is used as the 27.5-volt dc supply, it must have good voltage regulation and low ac ripple. Good regulation is important

because the output voltage of a supply having poor regulation, may exceed the maximum voltage rating of the transistors in the equipment being tested. A battery eliminator with poor ac filtering will create a false indication of poor filtering in the equipment being tested.

d. The direction finder set must be turned off before switching the battery eliminator on or off. The transient voltages developed by switching the battery eliminator on and off, may exceed the "punch-through" rating of transistor. Also, make certain that either a 600-ohm dummy load or a normal load (such as a headset) is connected to the direction finder set audio output before applying power.

e. Test Equipment Required.

Test equipment	Technical manual	Common name
Rf Signal Generator AN/URM-25 ()	TM 11-5551	Signal generator
Audio Oscillator TS-382/U *	TM 11-6625-261-12	Audio oscillator
Multitester ME-26/U	TM 11-6625-200-12	Vtvm
Multimeter TS-352/U *	TM 11-5527	Multimeter
Oscilloscope AN/USM-140 *		Oscilloscope
Output Meter TS-585/U	TM 11-5017	Output meter
Frequency Meter AN/USM-26 () *	TM 11-5057	Counter
Transistor Test Set TS-1836/U	TM 11-6625-539-15	Transistor tester
Test Set, Direction Finder Set AN/ARM-93	TM-11-6225-821-12	Test set
Electronic Maintenance Kit TK-100/G		
Electronic Maintenance Kit TK-105/G		
Headset		

* Or equivalent. Refer to Maintenance Allocation Chart in TM 11-5826-225-12.

Section II. TROUBLESHOOTING RADIO RECEIVER R-1391/ARN-83

2-4. Test Setup

All bench tests of the receiver, require connections to a 27.5-volt dc power source; Test Set, Direction Finder Set AN/ARM-93; and various other types of test equipment depending on the particular test. To prepare the receiver for tests, loosen the dust cover retaining screws (fig. 2-1) and slide the receiver out of its dust cover. Remove the gear train cover and the RF shield. Make the test setup as described below.

a. *Confections.*

- (1) Connect the receiver and test set as shown in figure 2-2, Use the pendant cable, the sense antenna adapter cable, and cable W3 from the test set.

- (2) Connect the output meter to the AUDIO OUT terminals on the test set.
- (3) Connect the R.F. OUTPUT X-MULT output connector of the signal generator to the SIGNAL GENERATOR connector on the test set. Use cable W2 of the AN/ARM-93.
- (4) Set the switch on the sense antenna adapter to 150PF.
- (5) After making certain the test set DC POWER switch is off, connect the dc power source to the test set. If the aircraft dc source is not available, use a battery eliminator capable

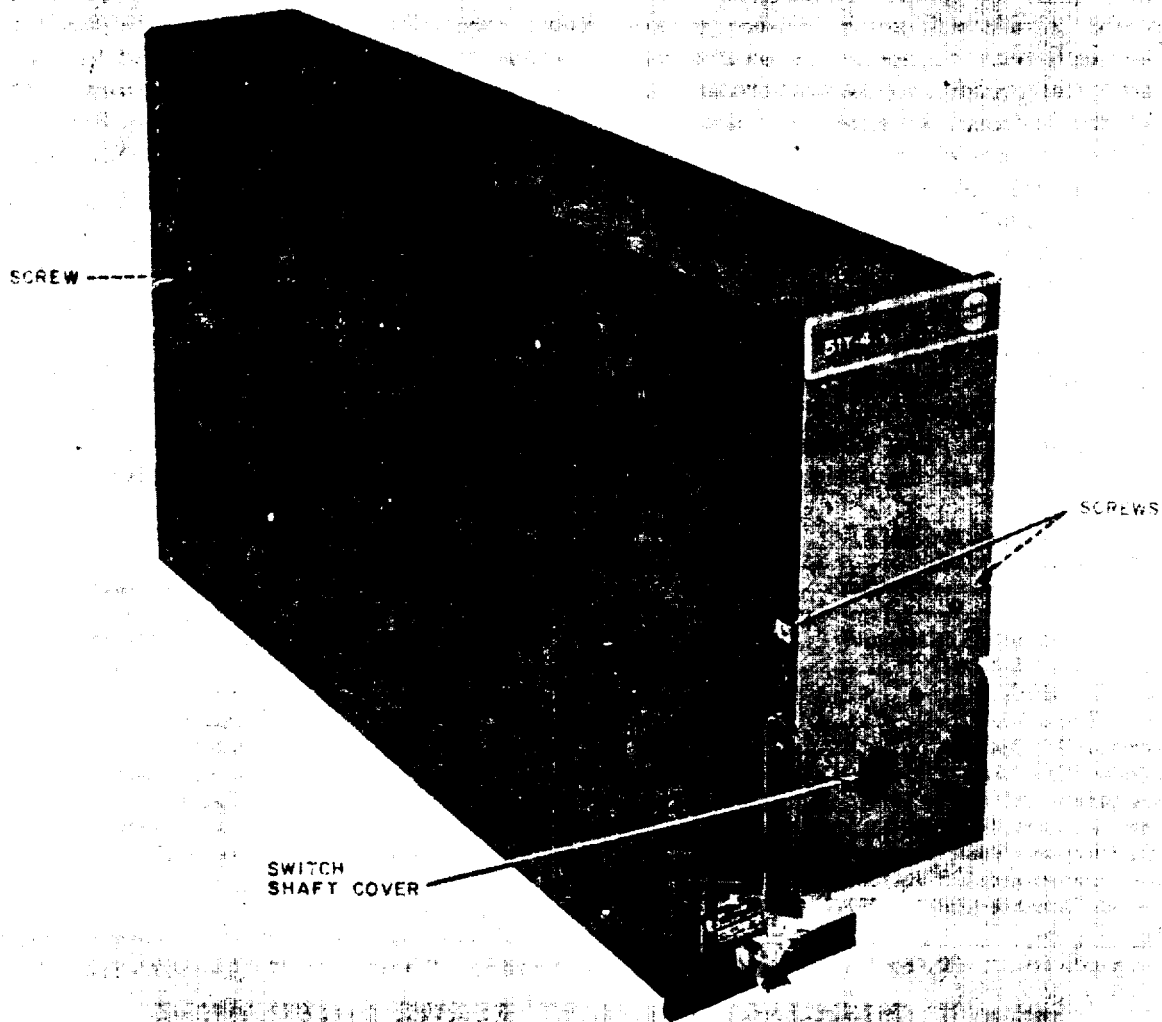

TM5826-225-35-29

Figure 2-1. Receiver, dust cover retaining screws location,

of supplying 27.5 volts dc at 3 amperes.

b. **Test Equipment.** The test set has circuitry for simulating the loop and sense antennas and provisions for rotating the apparent loop antenna magnetic field 360° in either direction. A bearing indicator and phone jack are also provided. The test setup shown in figure 2-2 is a preliminary troubleshooting test setup. Test connections will vary from test to test.

2-5. Localizing Troubles

a. **General.** The troubleshooting chart (d below)

contains procedures for localizing troubles to the af, IF, and RF sections of the receiver, and for localizing troubles to a stage within the various section. Parts location is indicated in figures 2-3 through 2-16.1. Depending on the nature of the operational trouble symptom, one or more of the localizing procedures will be necessary. When use of the procedures results in localization of trouble to a

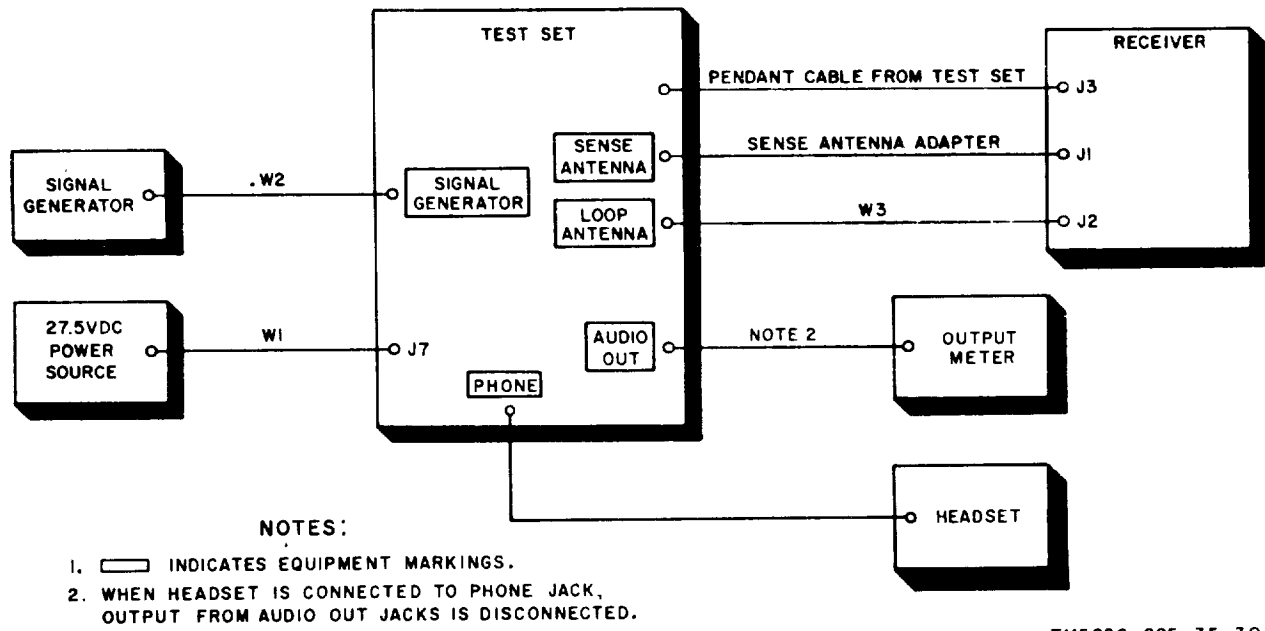

TM5826-225-35-30

Figure 2-2. Receiver test setup.

particular stage, use the techniques outlined in paragraphs 2-6 through 2-8 to isolate the trouble to a particular part.

b. *Use of Chart.* The troubleshooting chart in this manual supplements the operational checks and troubleshooting instructions included in TM 11-5826-225-12. If operational checks in TM 11-5826-225-12 have resulted in reference to a particular item of the chart, start with this referenced item.

c. *Conditions for Tests.* All checks outlined in the chart are to be conducted with the receiver connected to Test Set, Direction Finder Set AN/ARM-93 as indicated in figure 2-2. Unless otherwise indicated in the chart, set the control unit, test set, and signal generator controls as follows:

(1) *Test set.* Set the test set controls as follows:

<i>Control</i>	<i>Position</i>
RECEIVER-	
CONTROL _____	RECEIVER
GONIO DRIVE	OFF
DC POWER -----	ON

(2) *Control unit.* Set the control unit controls as follows:

<i>Control</i>	<i>Position</i>
BFO-OFF _	OFF
Function switch	ANT
Range switch -----	190-400
TUNE -----	200 kc
GAIN	Maximum clockwise position

(3) *Signal generator.* Tune the signal generator to 200 kc and set the controls for an RF output signal of 50 microvolt, modulated 30 percent at 400 cps.

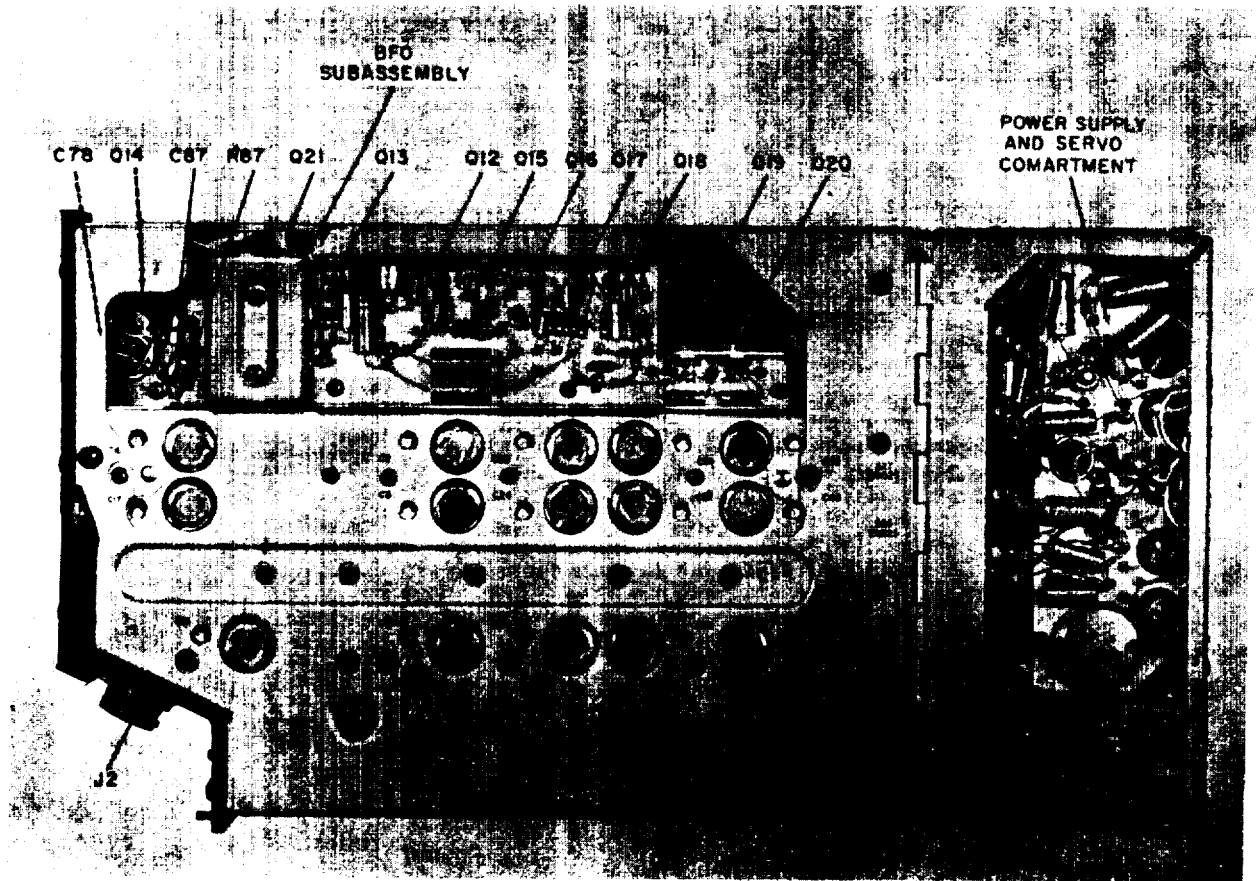
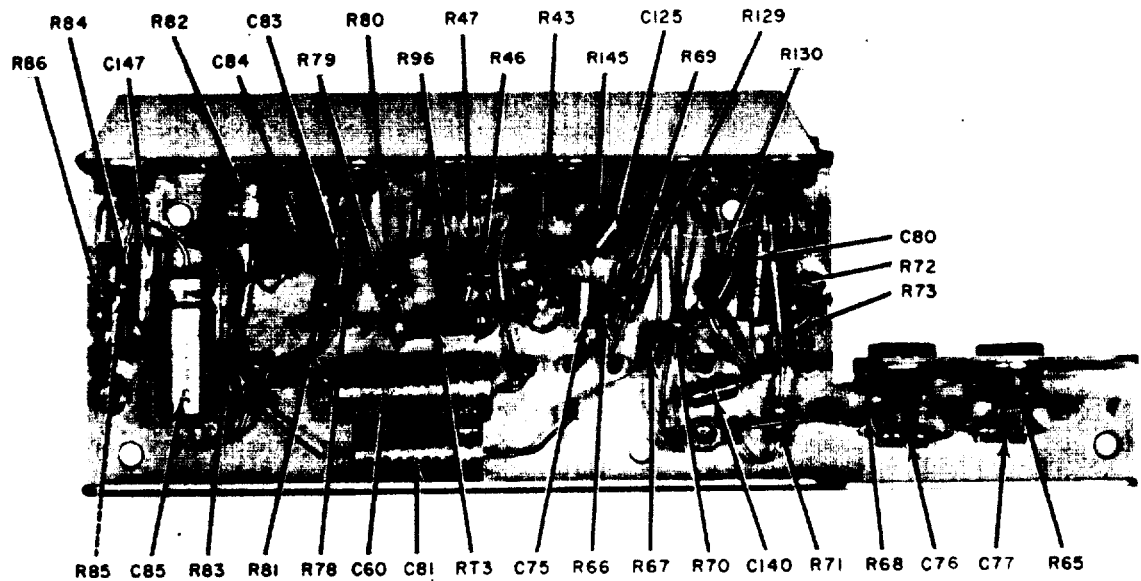
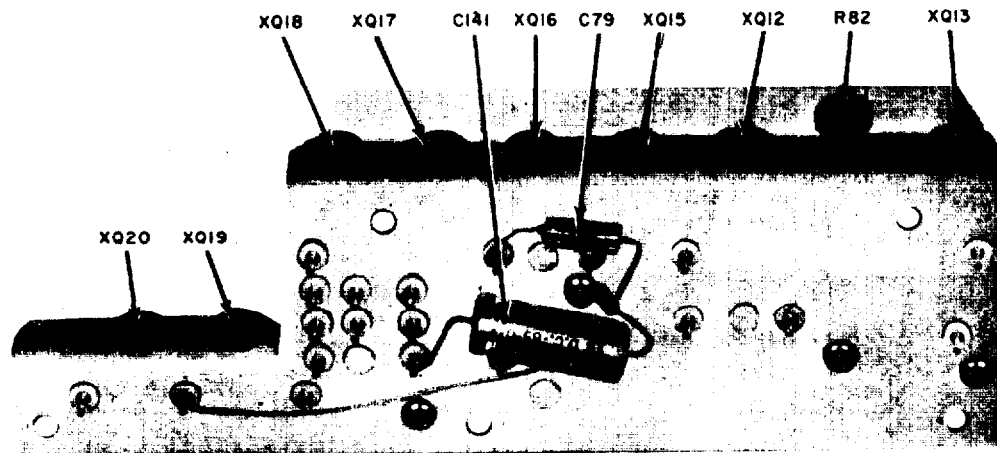

Figure 2-3. Receiver, right side view.



A. FRONT VIEW



B. REAR VIEW

TM5826-225-35-32

Figure 2-4. Audio frequency amplifier assembly.

Change 5 2-7

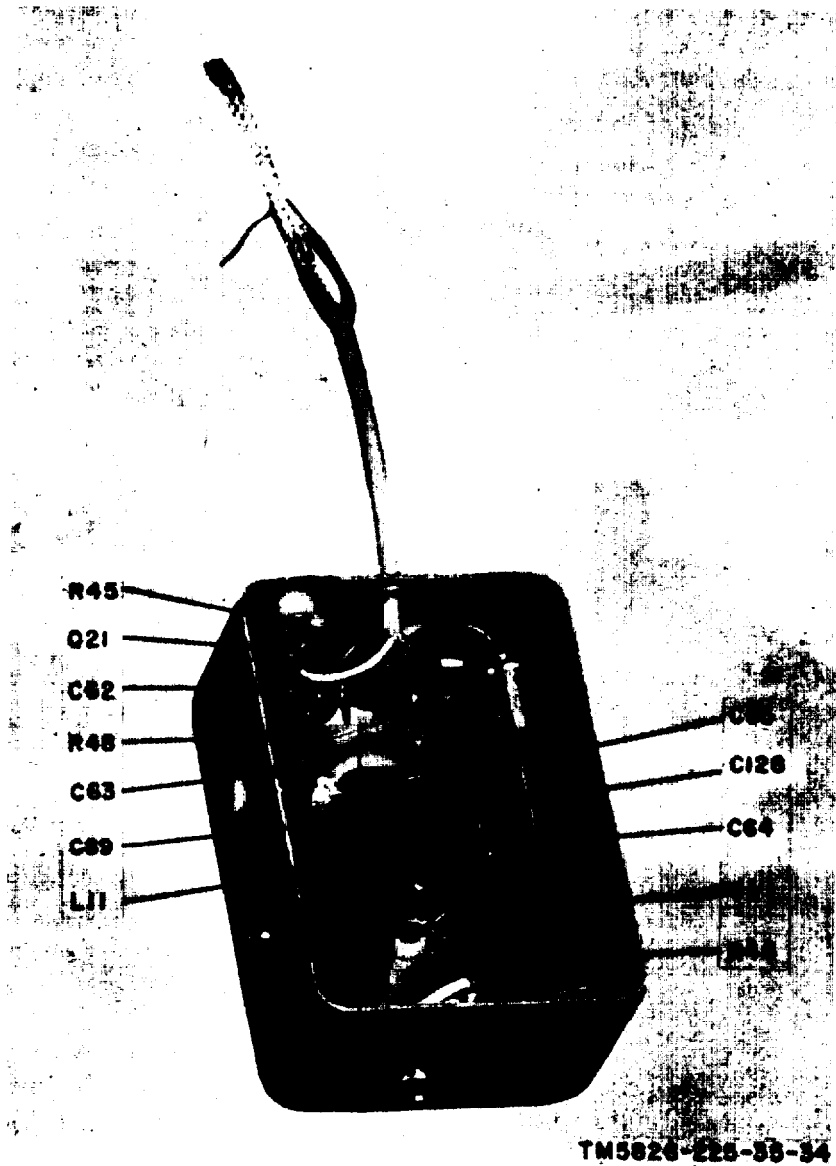

Figure 2-5. Bfo subassembly.

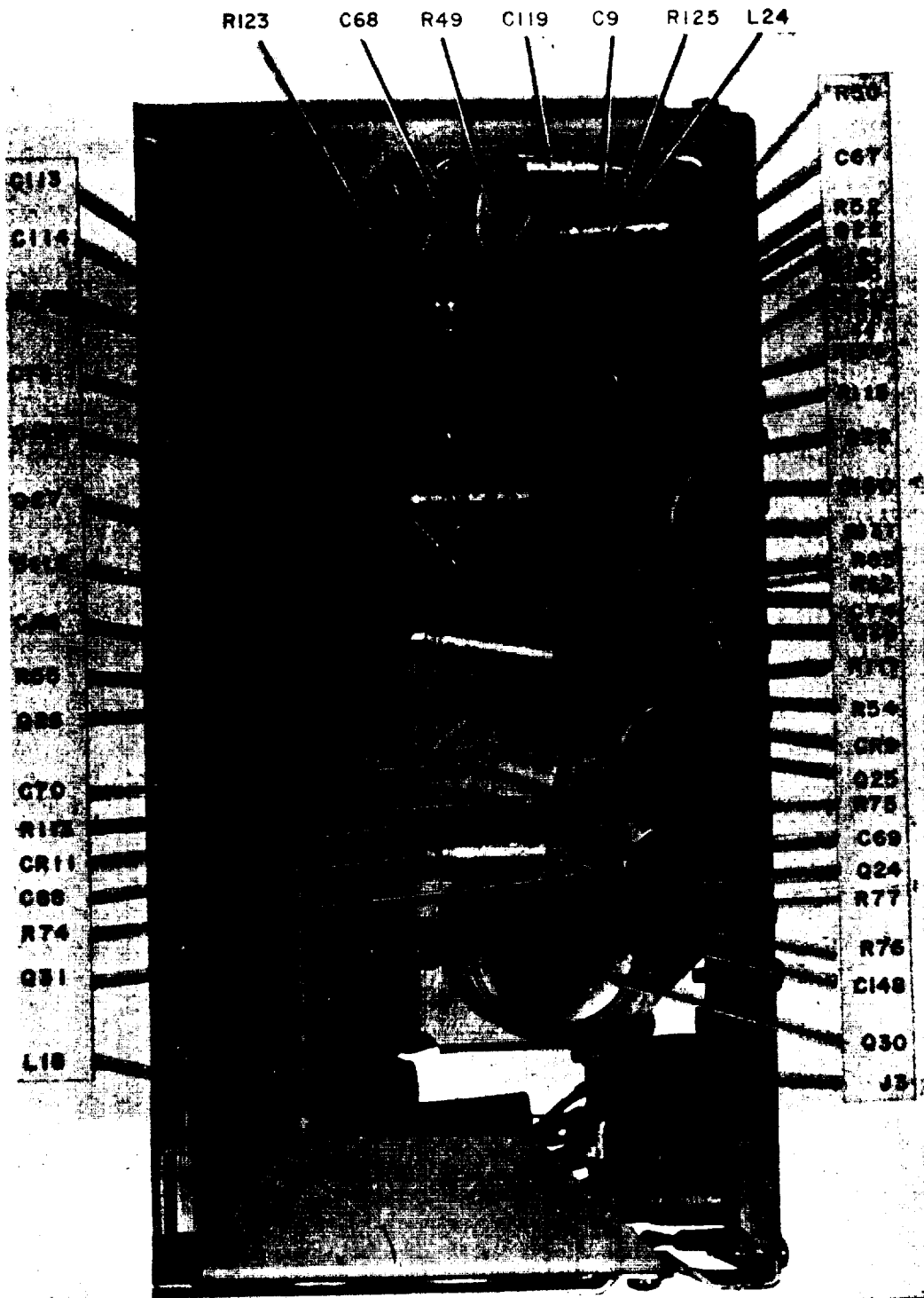

Figure 2-6. Power supply and servo compartment, right side view.

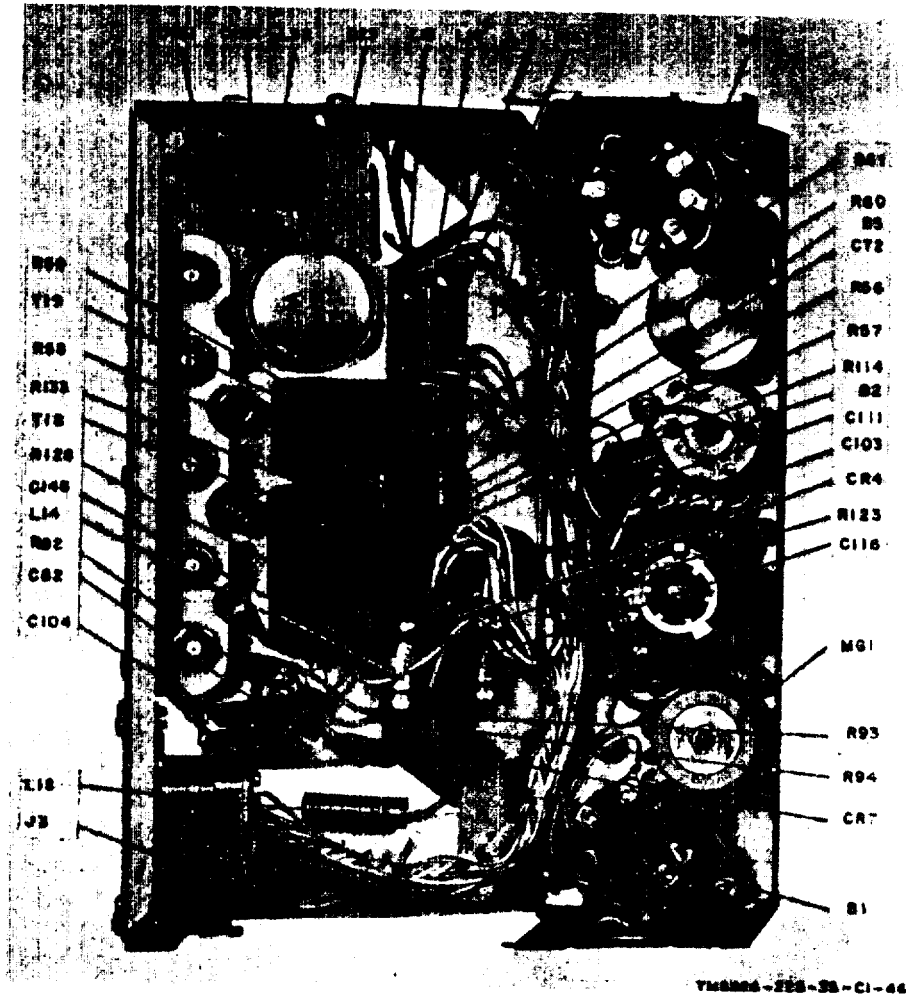
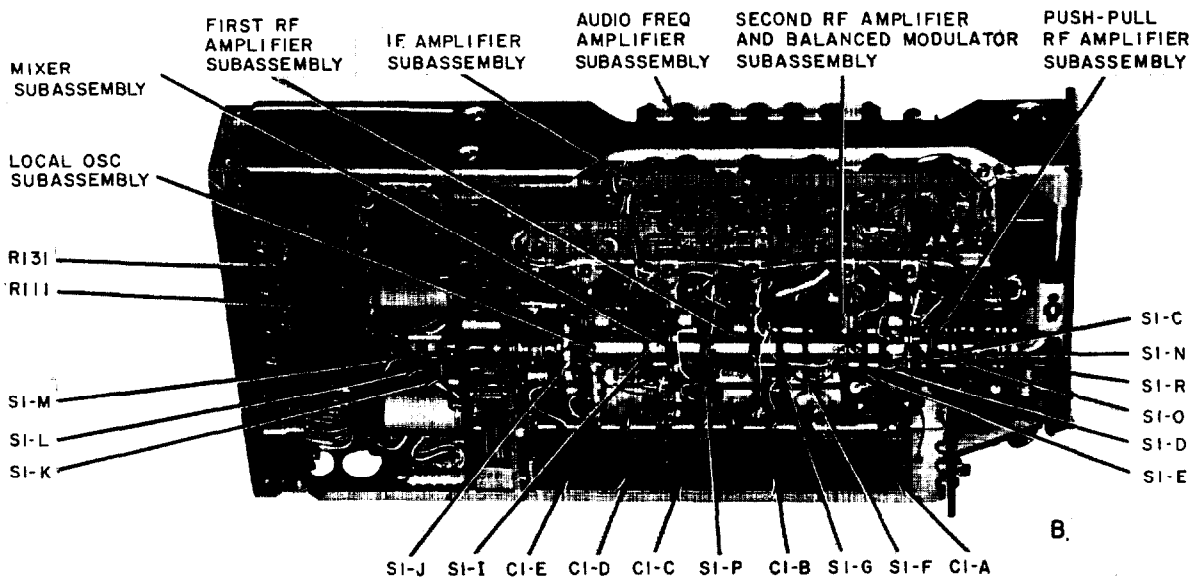
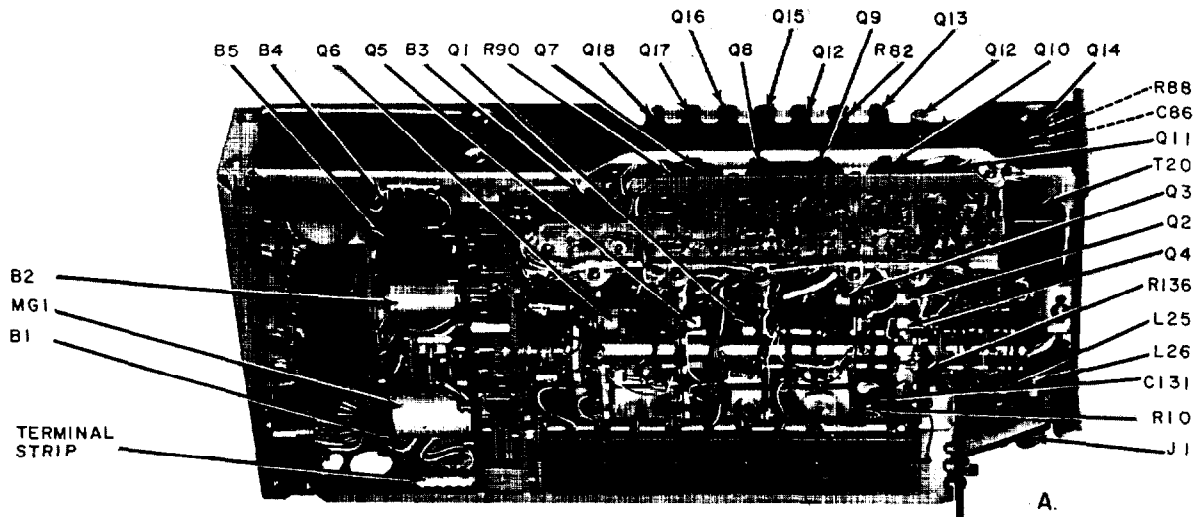

Figure 2-7. Power supply and servo compartment, rear view.



TM5826-225-35-36

Figure 2-8. Receiver, left side view with gear train cover and RF shield removed.



Figure 2-9. First RF amplifier subassembly.

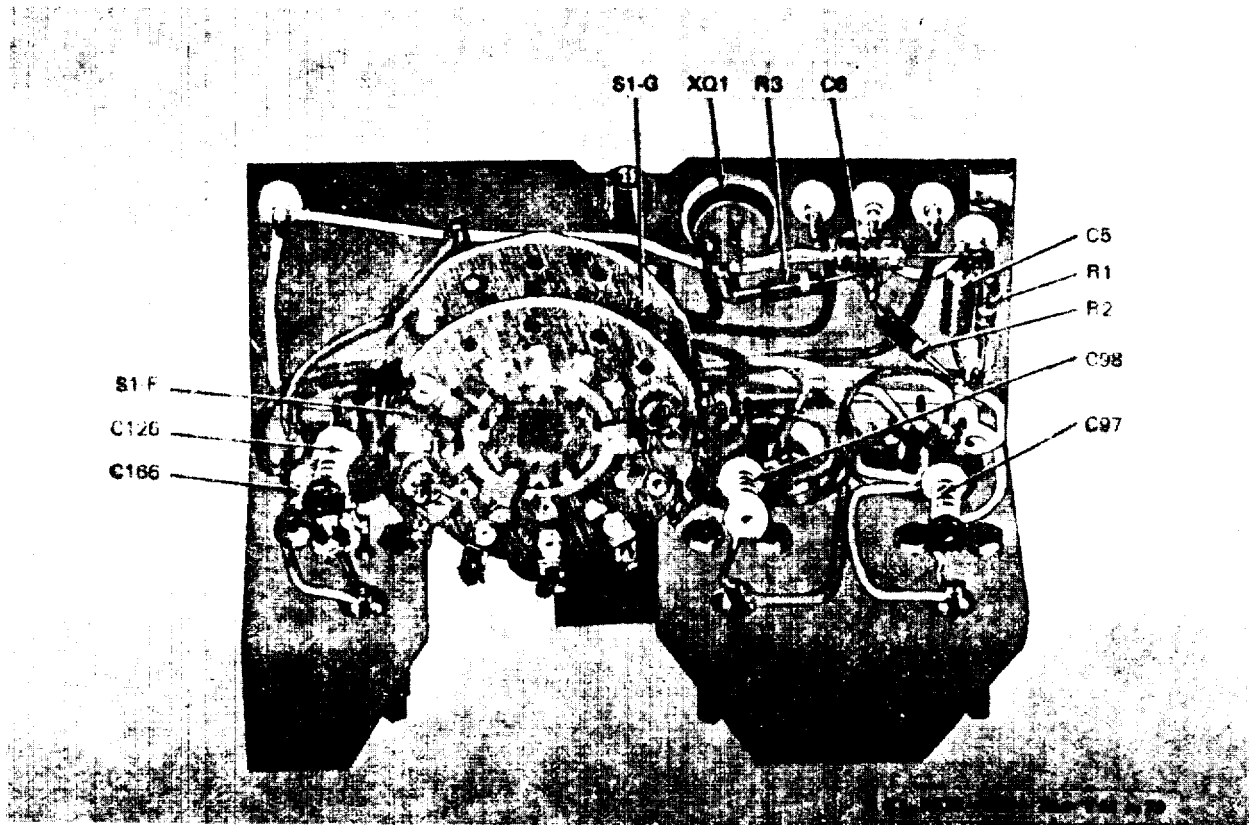

*Figure 2-9.1 First RF amplifier subassembly,
front view (MCN 1084 and above).*

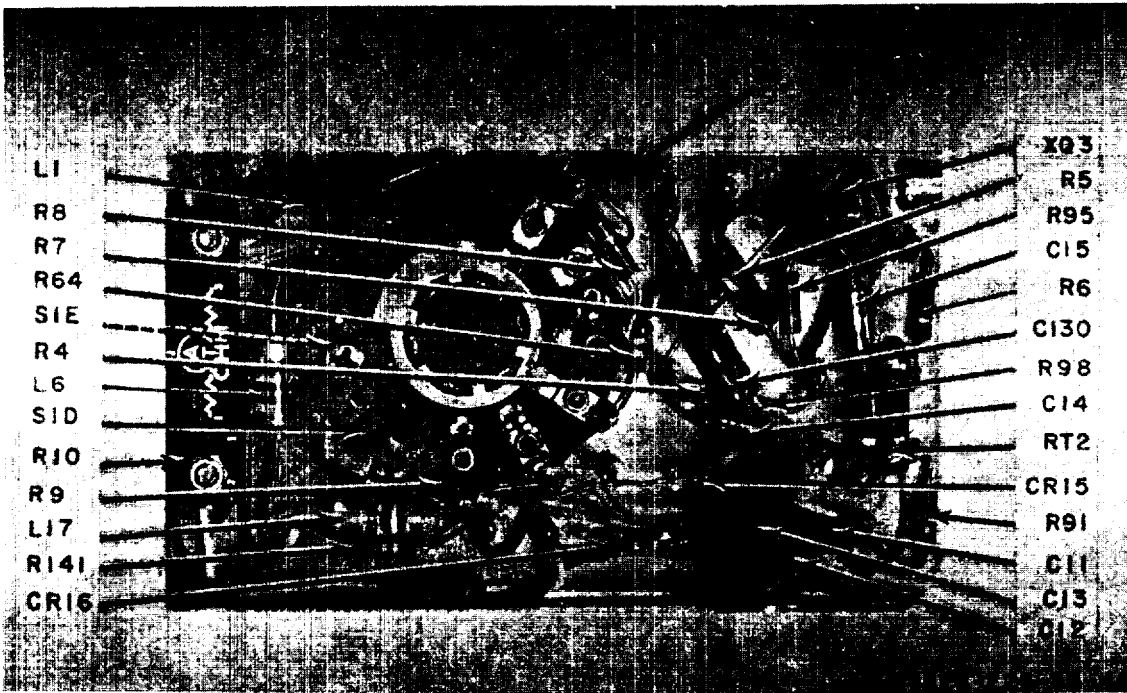

Figure 2-10. Second RF amplifier and balanced modulator subassembly.

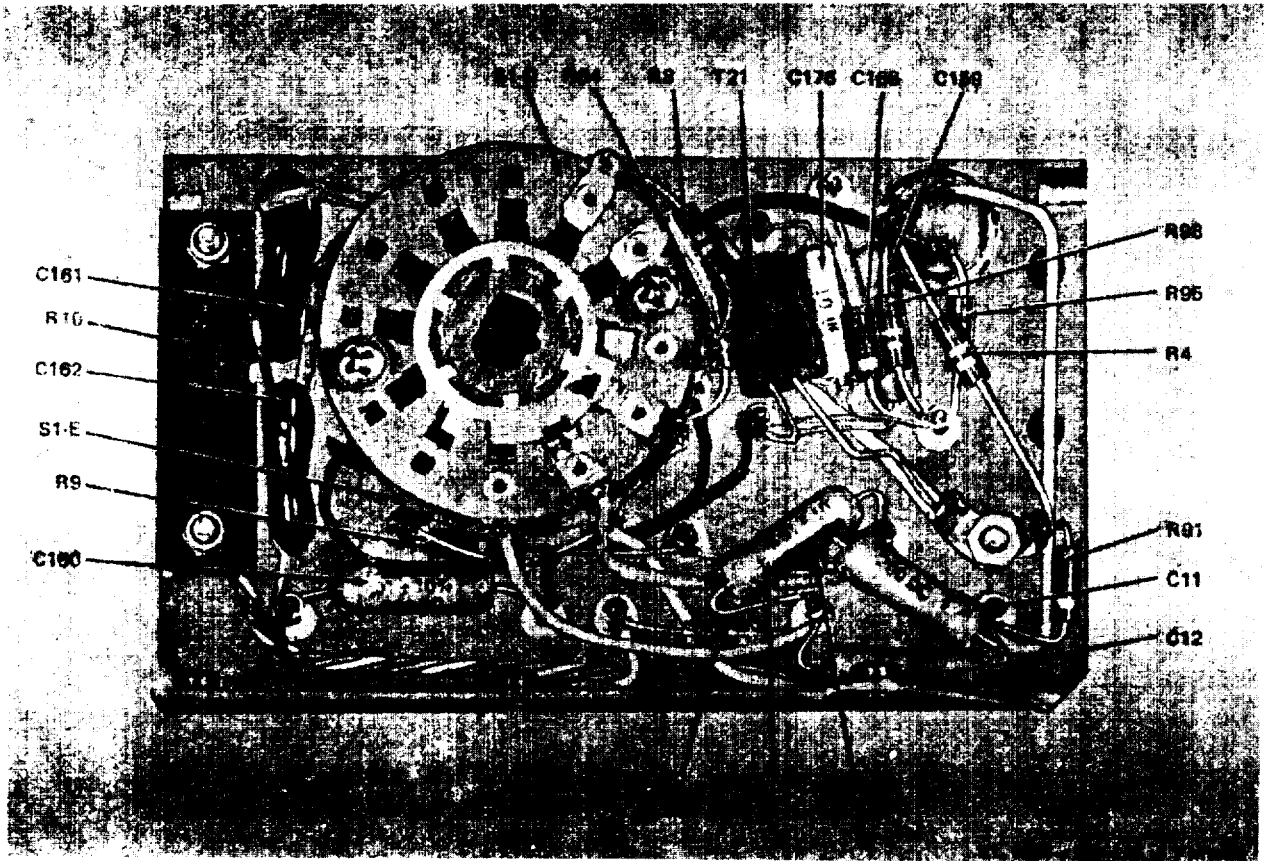

Figure 2-10.1 Second RF amplifier and balanced modulator subassembly (MCN 1084 and above).

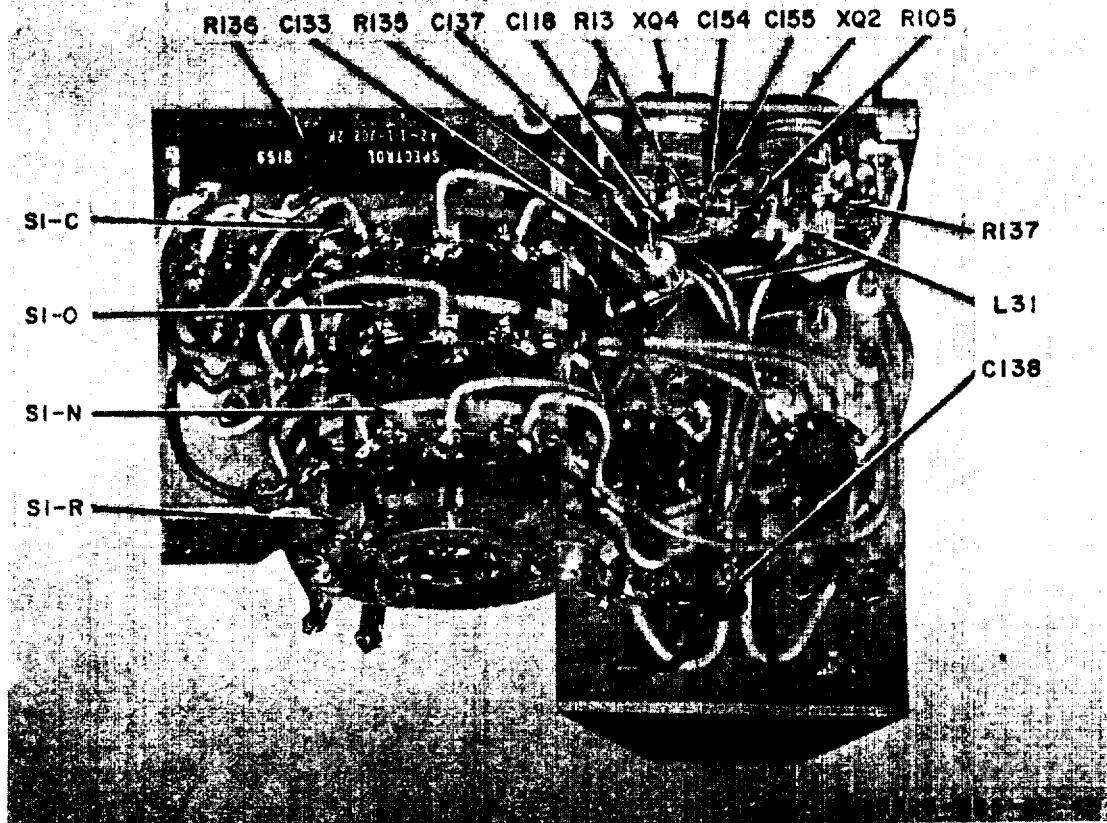
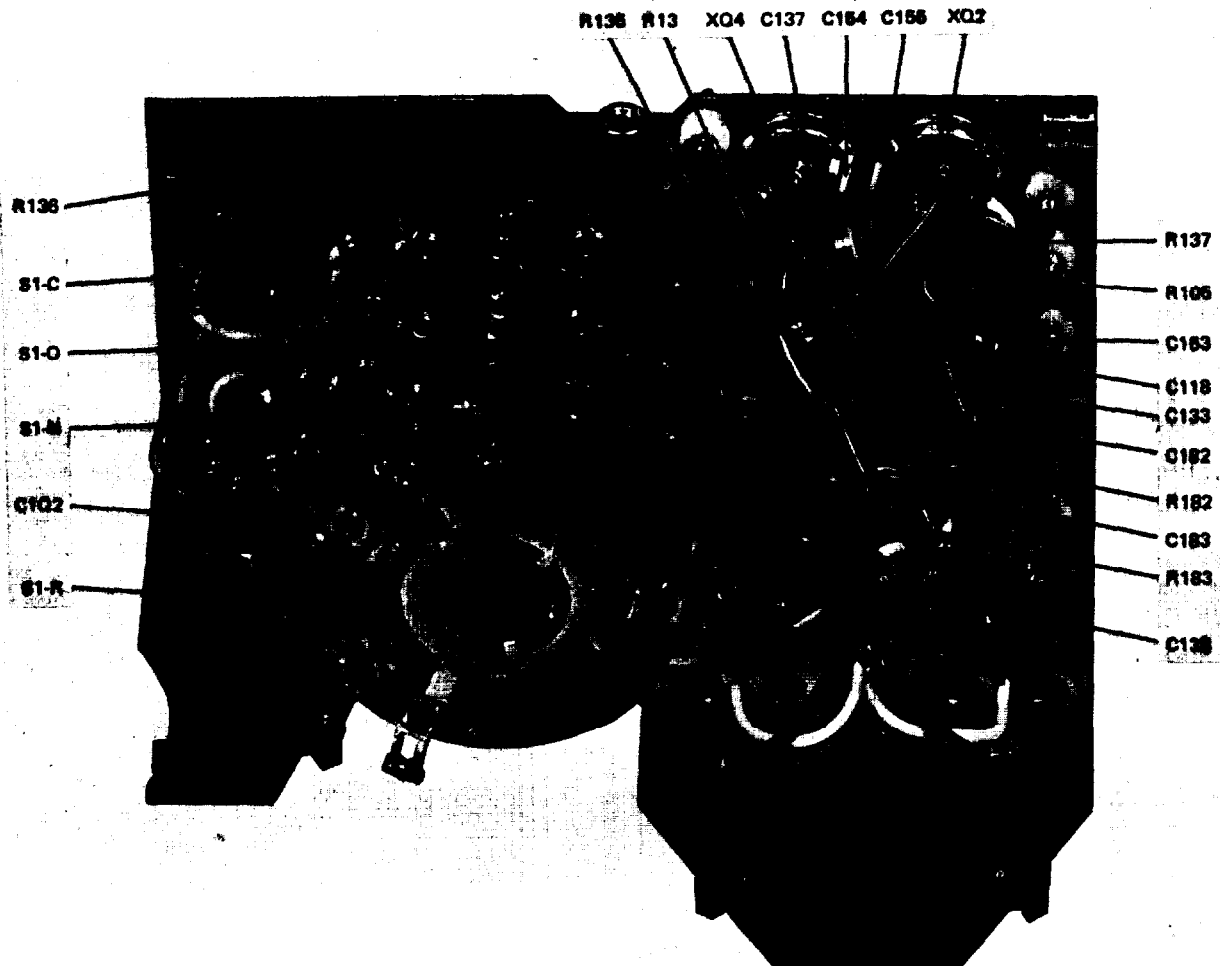

Figure 2-11. Push-pull RF amplifier subassembly, front view.



KL 5826-225-35-TM-81

Figure 2-11.1 Push-pull RF amplifier subassembly, front view (MCN 1084 and above).

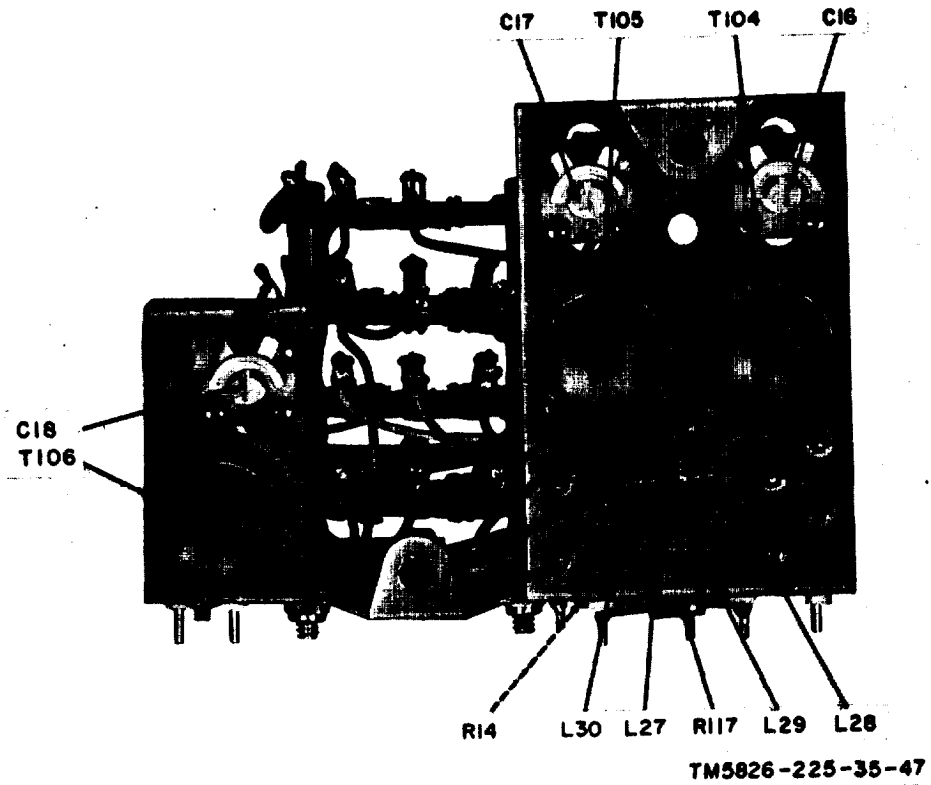
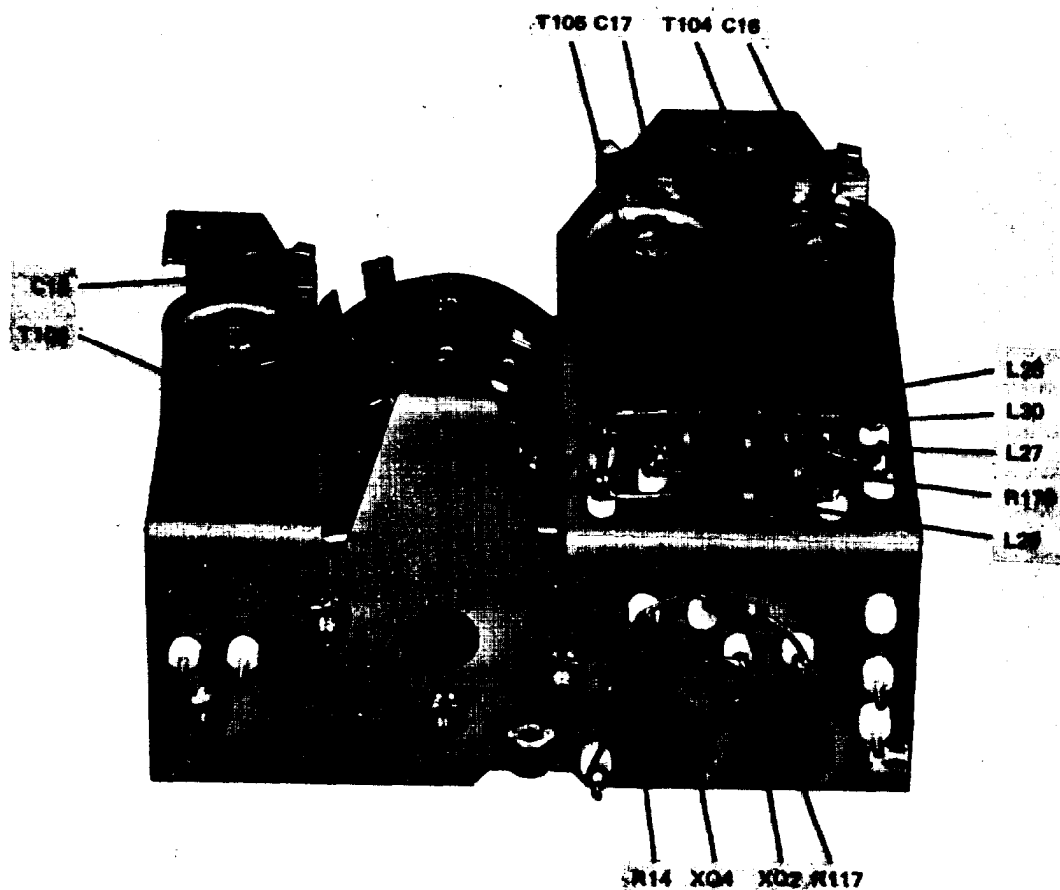
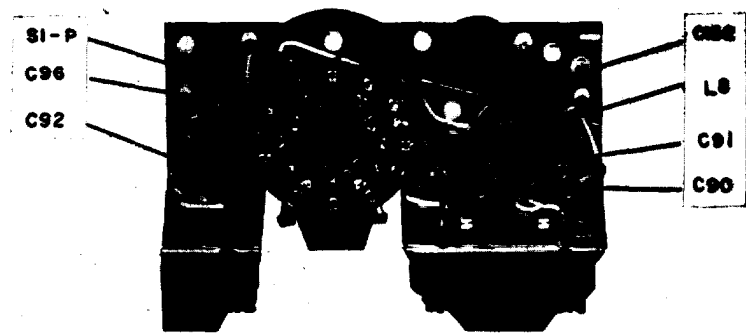

Figure 2-12. Push-pull RF amplifier subassembly, side view.



EL 5826-225-35-TM-02

Figure 2-12.1 Push-pull RF amplifier subassembly, side view (MCN 1084 and above).



A. FRONT VIEW

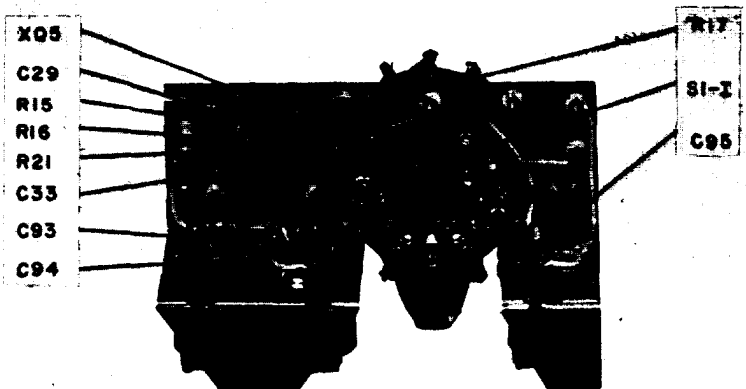

B. REAR VIEW

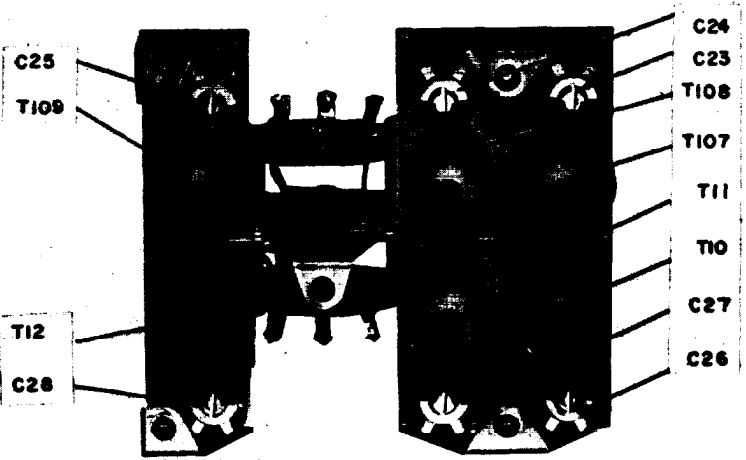

C. RIGHT SIDE VIEW

TM5826-225-35-38

Figure 2-18. Mixer assembly.

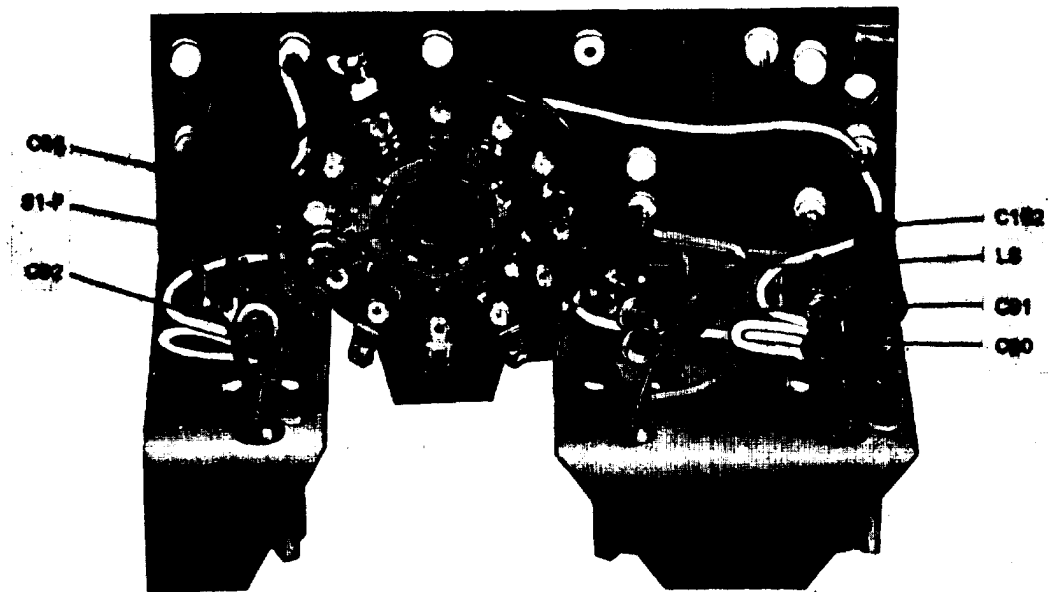

EL 5826-225-35-TM-83

Figure 2-13.1 Mixer assembly, front view
(MCN 1084 and above).

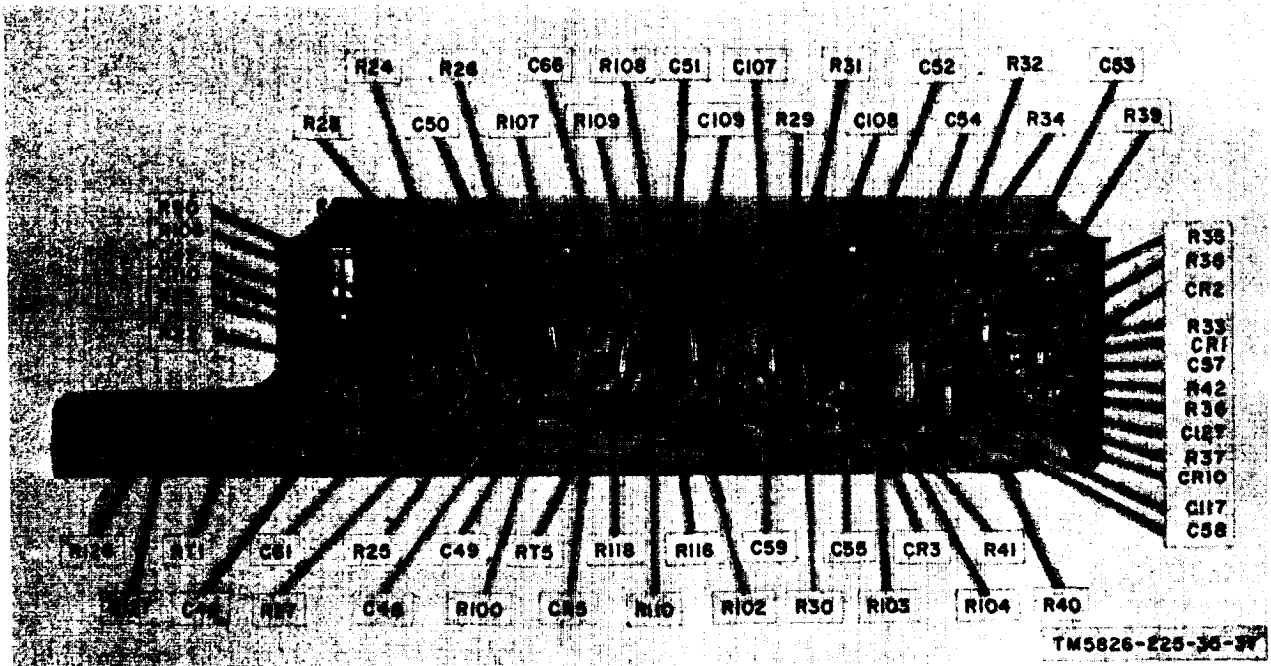
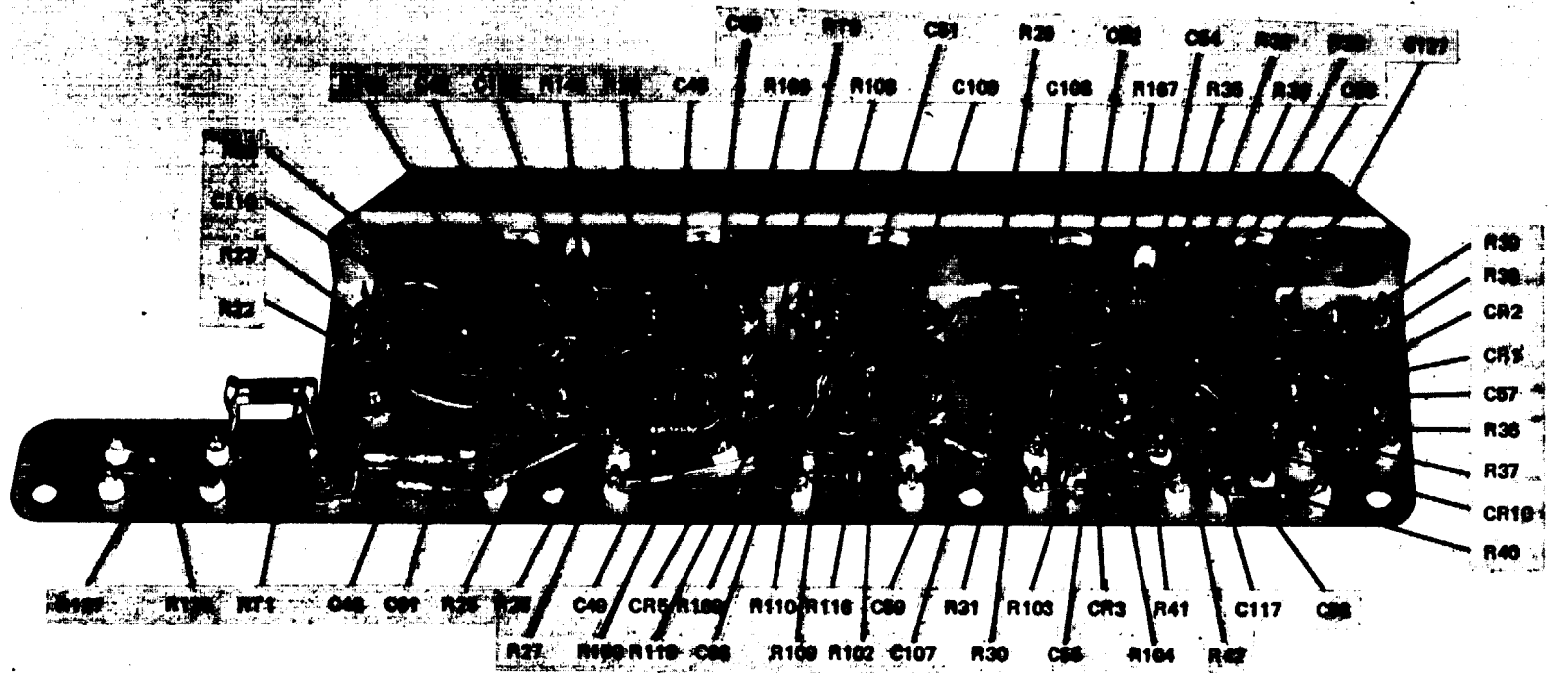

Figure 2-14. IF amplifier subassembly front view.



EL 5826-225-35-TM-84

Figure 2-14.1 IF amplifier subassembly, front view (MCN 1084 and above).

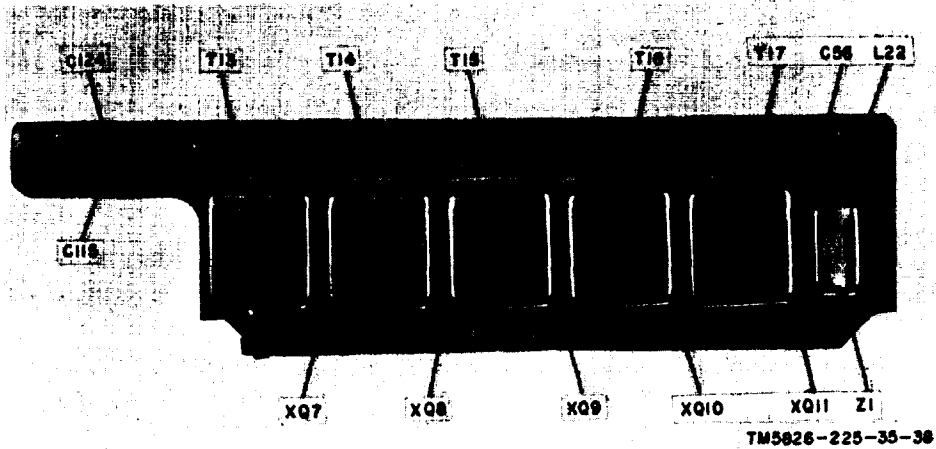

Figure 2-15. IF amplifier subassembly, rear view.

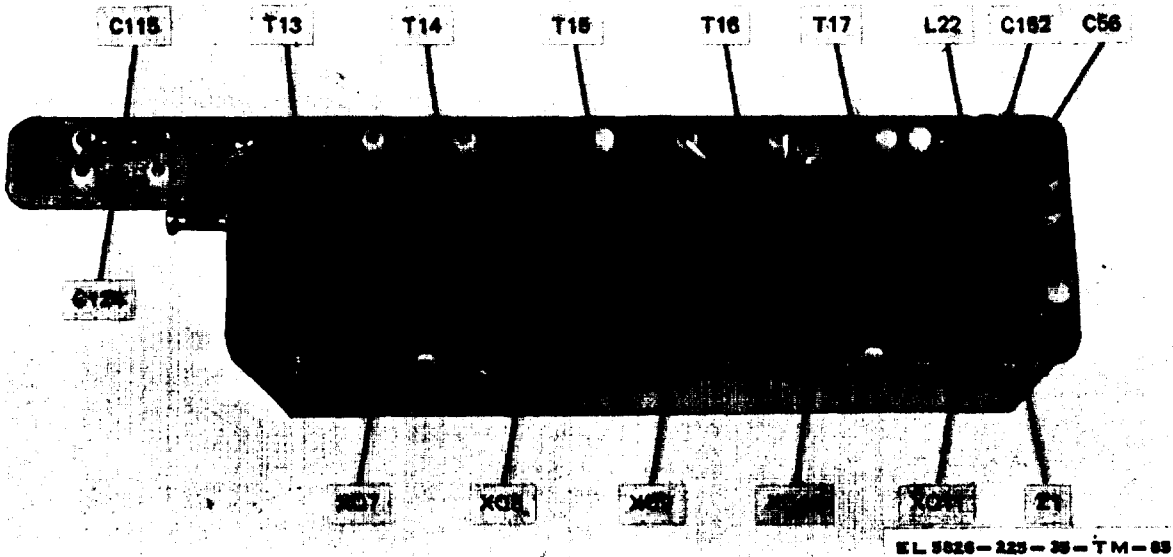
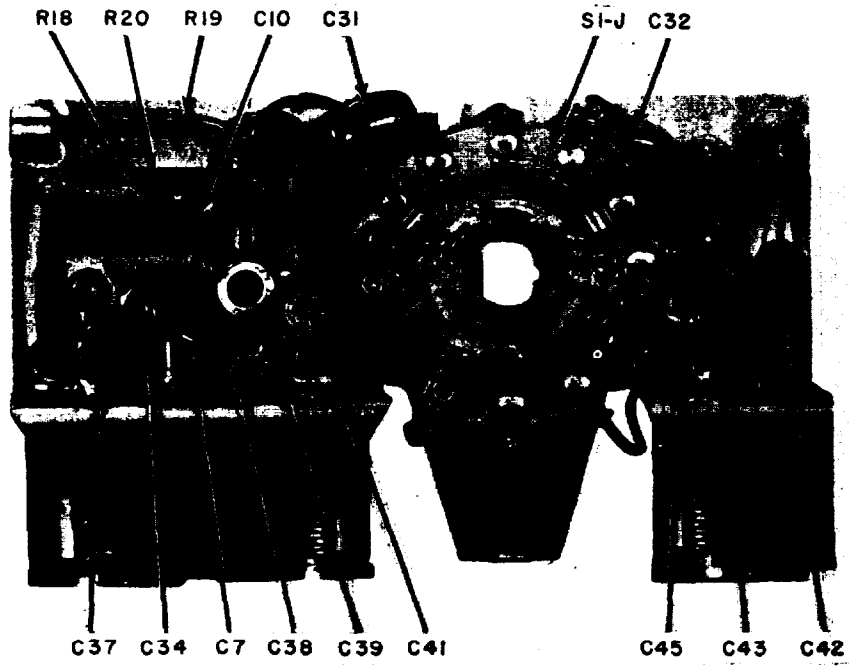
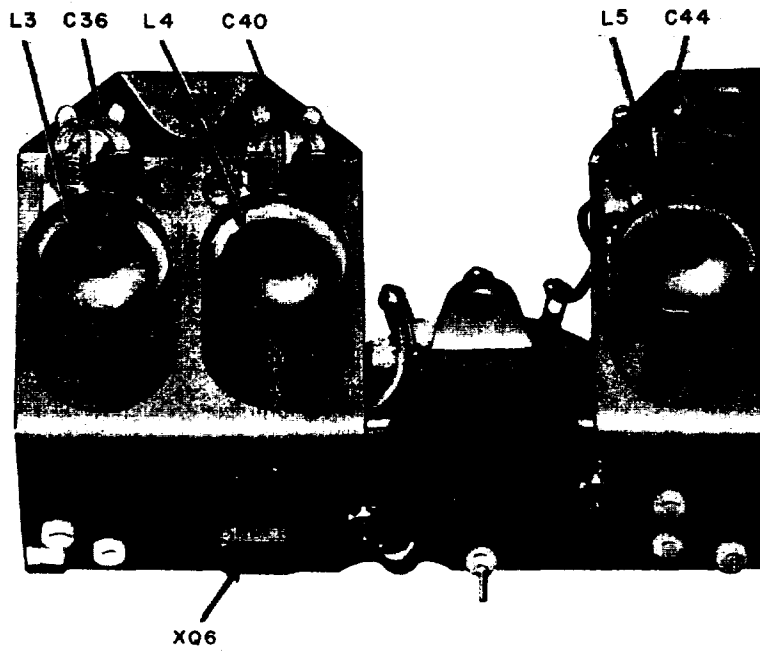

Figure 2-15.1 IF amplifier subassembly, rear view (MCN 1084 and above).



A. REAR VIEW



B. SIDE VIEW

TM5826-225-35-42

Figure 2-16. Local oscillator subassembly.

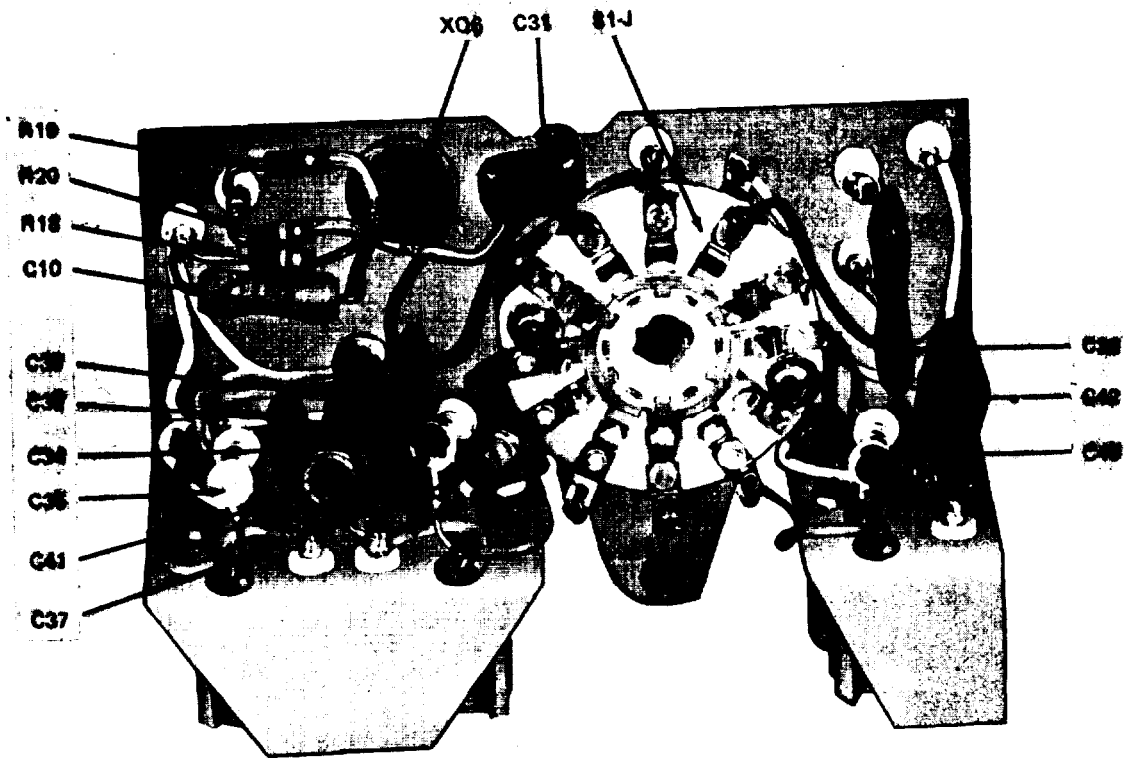

EL 5826-225-35-TM-86

Figure 2-16.1 Local oscillator assembly, rear view
(MCN 1084 and above).

d. Receiver Troubleshooting Chart.

	Indication	Probable trouble	Procedure
1	No audio output but control unit tuning meter indicates signal strength.	Defective audio output stage First or second audio amplifier stage defective. Audio detector defective ---- Network Z1 defective _____ Fifth IF amplifier defective.	Remove power and check transistor Q14 (fig. 2-3) with Transistor Tester TS-1836/U. Make voltage measurements on audio output stage (fig. 2-17). Make continuity tests on audio output transformer T20 (para 2-9a). Remove power and check transistors Q12 and Q13 (fig. 2-4). Make voltage measurements on first and second audio amplifier stages (fig. 2-17). Using vtvm, check voltage output from cathode of audio detector CR1 (fig. 2-14 or 2-14.1) Check continuity of Z1. Check transistor Q11 (fig. 2-8), Make voltage measurements (fig. 2-17). Check transistor Q21 (fig. 2-3).
2	With control unit BFO-OFF switch to BFO, no beat notes can be heard in headset connected to PHONE jack on test set.	Bfo defective ---. -. ____	Make voltage measurements (fig. 2-17).
3	Audio output is normal but control unit tuning meter is inoperative.	Meter rectifier defective ____	Using vtvm, check dc output voltage of diode CR10 (fig. 2-14 or 2-14.1) ,
4	No audio output or tuning meter indication.	Regulated power supply defective. First, second, third, or fourth IF amplifier stage defective. Mixer stage _____	See item 9 Check transistors Q7, Q8, Q9, and Q10 (fig. 2-8). Make voltage measurements (fig. 2-17). Make continuity checks on IF transformers T14, T15, T16, and T17 (para 2-9a). Perform signal substitution tests (para 2-6). Make stage gain measurements (para 2-7). Check mixer Q5 (fig. 2-8). Make voltage measurements (fig. 2-17). Check continuity of T13 (para 2-9a). Check oscillator Q6 (fig. 2-8). Make voltage measurements (fig. 2-17).
5	Audio output missing on one or more frequent ranges,	Local oscillator stage defective. Switch wafer S1-J dirty--- Oscillator out of alignment . Automatic gain control circuit defective.	Make continuity checks on oscillator coils (para 2-9a). Clean switch contacts (fig. 2-8). Align oscillator (para 3-13).
6	Signal output varies		Using transistor tester, check agc amplifiers Q15 and Q16 (fig. 2-3).
7	First IF amplifier Q7		Using vtvm, check dc output voltage of agc rectifier CR3 (fig. 2-14 or 2-14.1) Make voltage measurements on agc amplifiers Q15 and Q16 (fig. 2-3).
R	Weak audio output on one or more frequency ranges.	Sense antenna input circuit or push-pull RF amplifier.	Check transistors Q2 and Q4 (fig. 2-8). Make voltage measurements (fig. 2-17).

Item	Indication	Probable trouble	Procedure
		Push-pull RF amplifier and mixer coupling network out of alignment. Sense antenna input network out of alignment. Switch wafers not making contact.	Align network (para 3-14). Align network (para 3-14), Check continuity through contacts of switch wafers S1-C, S1-0, S1-N, and S1-R (fig. 2-8)
9	Regulated power supply defective.		Check transistors Q30 and Q31 (fig. 2-6). Make voltage measurements (fig. 2-17).
10	Noise heard in headset connected in PHONE jack on test set when receiver switches frequency ranges.	Receiver muting circuit	While receiver switches frequency ranges, check positive dc voltage, on base of agc amplifier Q16 (fig. 2-3). Base voltage should rise sharply. If not, replace diode CR5.
11	Receiver does not switch frequency ranges or functions.	switch wafer S1-M not closing dc voltage circuit to motor B2.	While receiver switches frequency ranges, check for presence of +27.5 volts on contacts of rear switch wafer S1-M (fig. 2-8), Clean switch if necessary.
12	Receiver does not tune to a radio station.	Servo amplifier Q26, Q27, Q28, or Q29 defective.	Check transistors (fig. 2-6). Make voltage measurements (fig. 2-17).
13	Tuning servo does not hold station frequency,	Capacitor C74 coupled to control winding of tuning servo motor.	Check capacitor (fig. 2-6)
14	Tuning servo hunts	Tachometer feedback variable resistor R111 out of adjustment.	Adjust R111 (para 3-10).
<p><i>Note.</i> Unless otherwise indicated for items 15 through, 18, set control unit and test equipment controls as follows :</p> <p>(1) On the, test set, place DC POWER to ON, GONIO DRIVE to ON. and loop simulator control for an indication on LOOP SIMULATOR 90 degrees more. than indicated on HEARING INDICATOR.</p> <p>(2) Tune signal generator to 200 kc with an RF Output of 50 microvolts unmodulated.</p> <p>(.3) On the control unit, set function switch to ANT, range switch to 190-400, GAIN to maximum clockwise position, BFO-OFF to BFO, and TUNE for zero-beat on 200 kc. After zero-beat, set BOF-OFF to OFF and function switch to ADF.</p>			
15	When test set LOOP SIMULATOR control is set for 90-degree indication from indicated bearing BEARING INDICATOR rotates hut does not reach a null.	Loss of 110-cps reference phase voltage on reference winding of servo motor B5 because of defective 110-cps amplifier stage.	Using oscilloscope, check for waveforms on base and collector of Q23 (fig. 2-7). If present, compare waveforms taken with those shown in figure 2-18. Make voltage measurements on stage of Q23 (fig. 2-17). Using transistor tester, check Q23.

Item	Indication	Probable trouble	Procedure
16	Erratic operation of bearing indicator.	<p>110-CPS oscillator stage defective.</p> <p>Push-pull resolver servo amplifier stage.</p> <p>Balanced modulator balance adjustment variable resistor R10.</p> <p>Loss of 110 cps on balanced modulator by reason of switch wafer S1-D not making contact.</p> <p>First or second RF amplifier stage defective.</p> <p>Power supply variable resistor R131 out of adjustment (provides base and emitter bias voltages for first resolver servo amplifier Q17).</p> <p>110-cps oscillator or 110-CPS amplifier defective.</p> <p>Push-pull resolver servo amplifier stage.</p> <p>First or second resolver servo amplifier stage defective.</p> <p>Synchronous filter stage defective.</p> <p>First agc amplifier defective (emitter follower function drives synchronous filter).</p>	<p>Check continuity of reference winding of B5. Using transistor tester, check transistor Q22 (fig. 2-6).</p> <p>With oscilloscope, check waveforms on base and collector of Q22 (fig. 2-18).</p> <p>Make voltage measurements (fig. 2-17).</p> <p>Check continuity of coil L32 (para 2-9a).</p> <p>Check transistors Q24 and Q25 (fig. 2-6).</p> <p>Make voltage measurements on Q24 and Q25 (fig. 2-17).</p> <p>Adjust R10 (para 3-19).</p> <p>Check continuity through switch contacts of S1-4 (fig. 2-8). Clean contacts if corroded.</p> <p>Check transistors Q1 and Q3 (fig. 2-8).</p> <p>Make voltage measurements (fig. 2-17).</p> <p>Adjust R131 (fig. 2-8 and para 3-20).</p> <p>See item 15.</p> <p>See item 15.</p> <p>Check transistors Q17 and Q18 (fig. 2-8).</p> <p>Make voltage measurements (fig. 2-17).</p> <p>Check transistors Q19 and Q20 (fig. 2-3).</p> <p>Make voltage measurements (fig. 2-17).</p> <p>Using oscilloscope, check 110-CPS waveforms on bases of Q19 and Q20. Compare with waveforms in figure 2-18.</p> <p>Check transistor Q16 (fig. 2-3).</p> <p>Make voltage measurements (fig. 2-17).</p> <p>Using oscilloscope, check for presence of 110-cps on base and emitter of Q16.</p> <p><small>Note. Before continuing with items 17 and 18, set control unit function switch to LOOP. Modulate signal generator output signal with approximately 30 percent modulation. Using LOOP switch, rotate bearing indicator to aural null in headset.</small></p> <p>Check filter capacitors.</p>
17	Will not reach aural null (sound will not cut off).	<p>Voltage regulator filter capacitor defective.</p> <p>Voltage regulator zener diode CR4 or CR11, oscillating.</p>	<p>Using oscilloscope or ac range of vtm, check for ac ripple on collector of Q30 and base of Q31 (fig. 2-6).</p>

Item	Indication	Probable trouble	Procedure
18	Control unit LOOP switch rotates bearing indicator pointer in one direction only.	Audio amplifier Q12, Q13, or Q14 defective. Loss of 110-CPS reference phase voltage on resolver servo motor B5.	Check transistors (fig. 2-3). See item 15.

2-6. Signal Substitution

a. General. Signal substitution procedures help to localize trouble to a stage in the receiver. An externally generated signal is substituted for the signal normally present in each stage. The test equipment required for the tests in b through d below is listed in paragraph 2-3e. In the following tests, ground one side of the audio oscillator or signal generator to the receiver chassis and conned the output lead to the receiver test point indicated. When performing these tests, use the receiver main schematic diagram (fig. 5-10 or 5-10.1.) in conjunction with the parts location illustrations referenced in the following procedures.

Caution: All circuits in the receiver are transistorized. To avoid transistor damage, use tape or sleeving to cover the test leads except for the extreme end required for testing,

b. Audiofrequency Tests. Start these tests at the output of the last audio amplifier stage and work back toward the first stage (figs. 2-3 and 2-4). Turn variable resistor R82 fully clockwise.

- (1) Connect the receiver to Test Set, Direction Finder Set AN/ARM-93 as shown in figure 2-2, but do not connect RF Signal Generator AN/URM-25. Set the test set and control unit controls as indicated in paragraph 2-5c. The range switch and TUNE control may be set in any position.
- (2) Set Audio Oscillator TS-382/U to produce an audio output signal of 400 cycles at 5 volts rms.
- (3) Using a 10-microfarad capacitor in series with the audio oscillator output lead, connect lead to the collector of audio amplifier Q14.

- (4) Listen for audio output signal in headset. If no signal is heard, check audio output transformer T20 and capacitor C78.
- (5) Set audio oscillator output signal level to 850 millivolts and apply signal to the collector of Q13. Audio output from the headset should be as loud as obtained in (4) above. If no sound is heard or output is low, check transistor Q14 and associated base signal input circuitry.
- (6) Set audio oscillator output signal to 33 millivolts and apply signal to the base of Q13. Sound output should be equal to that obtained in (4). If no sound is heard or sound level is weak, check transistor Q 13 and associated circuit components.
- (7) Adjust audio oscillator for an output of 42 millivolts and apply signal to the base of transistor Q12. Sound output in headset should he equal to that obtained in (4). If not, check transistor Q12 and associated circuit components.

Note. After making the above tests, adjust the variable resistor R82 in accordance with the instructions in paragraph 3-17.

c. Intermediate Frequency Tests. Start the tests at the output of the last IF amplifier stage and work back toward the first IF stage (figs. 2-8 and 2-15 or 2-15.1). Turn variable resistor R90 (fig. 2-8) fully clockwise.

- (1) Use the test setup described in paragraph 2-6b (1).
- (2) Set RF Signal Generator AN/URM-25 for a 142.5-kc output signal modulated 30 percent at 400 cps. Adjust output signal level to 50 millivolts.

Using the 50-ohm probe, apply signal to test point TP2 (collector of Q11 and network Z1).

- (3) Listen for audio output signal in headset. If no sound is heard, check network Z1, audio detector CR1, audio limiter CR2, and associated circuit components.
- (4) Apply signal generator RF signal to the base of transistor Q11. Audio output signal level should increase. If no sound is heard or sound is low, check transistor Q11 and associated circuit components.
- (5) Apply signal to the base of Q10. Audio output signal should increase. If not, check transistor Q10, IF transformer T17, coupling capacitor C53, and associated parts.
- (6) Adjust signal generator for an output level of 15 millivolts. Apply signal to the base of Q9. If no sound is heard or sound output is low, check transistor Q9, IF transformer T16, coupling capacitor C108, and associated circuit components.
- (7) Using a jumper wire, ground agc test point TP3. Adjust signal generator output signal to 250 microvolt and apply signal to base of Q8. If no sound is heard in headset or output is low, check transistor Q8, IF transformer T15, coupling capacitor C51, and associated circuit components.
- (8) Adjust signal generator for an output level of 10 microvolt and apply signal to base of transistor Q7. If no sound is heard or sound is low, check transistor Q7, IF transformer T14, coupling capacitor C48, and associated circuit components.
- (9) Adjust signal generator output level to 100 microvolt and apply signal to the collector of Q5 through the 50-ohm probe. If audio output signal is low or absent, check IF transformer T13, variable resistor R90, coupling capacitor C110, and associated components.

Note. After making the above tests, adjust variable resistor R90 in accordance with the instructions in paragraph 3-17. Remove ground from agc testpoint TP3.

d. Radio frequency Tests. Start the radio-frequency tests at the mixer stage and work back toward the antenna inputs.

- (1) Unless otherwise indicated, use the test setup described in paragraph 2-6b(1).
- (2) Turn variable resistor R90 (fig. 2-7) fully clockwise. Ground age testpoint TP3.
- (3) Adjust signal generator for a 200-kc unmodulated output signal at a level of approximately 5 microvolts. Using 50-ohm probe, apply signal to testpoint TP4 connected to junction of capacitor C29 and contact number 3 of front switch wafer S1-I (figs. 2-8 and 2-13 or 2-13.1).
- (4) Set control unit BFO-OFF switch to BFO and function switch to ANT. Adjust TUNE control for zero beat in headset then turn BFO-OFF switch to OFF.
- (5) Adjust signal generator controls for an output signal modulated 30 percent at 400 cps. If no sound is heard, check mixer Q5 and associated circuit components.
- (6) Using 50-ohm probe in series with signal generator output lead, apply 200-kc RF signal to the base of RF amplifier 4 (figs. 2-8 and 2-11).
- (7) ^{or 2-11.1} If no sound is heard or sound is low, check transistor Q4 and stage circuit components. Check condition of switch contacts on wafers S1-P and S1-1. Check alignment of RF amplifier and mixer coupling network used on the 190- to 400-kc range (para 3-14). Check RF transformers T107 and T10.
- (8) Apply signal to the base of transistor Q2. If no sound is heard in headset, check transistor Q2 and associated circuit components. Check condition of switch contacts on wafer S1-P.

- (9) Set control unit and signal generator controls for using RF test signals on the 400- to 850-kc and 850- to 1750-kc ranges. For each test signal, set control unit BFO-OFF switch to BFO and tune for zero beat. Then set BFO-OFF switch to OFF. Using the 50-ohm probe, apply modulated signal to the base of Q4. If no sound is heard or sound output is weak on either frequency range, check the alignment of tuned circuit (para 3-14). Check RF transformers.
- (10) Use the test setup shown in figure 2-2 and described in paragraph 2-6b(1). Connect RF signal generator to input of test set. Do not use 50-ohm probe. Set signal generator for a 200-kc unmodulated output signal at a level of 50 microvolt.
- (11) Set control unit BFO-OFF switch to BFO and tune unit to 200 kc. Adjust signal generator for zero beat and then set BFO-OFF switch to OFF. Modulate signal generator 30 percent at 400 cps.
- (12) Listen for sound in headset. If sound is weak or missing, check condition of switch contacts on wafers S1-R, S1-N, S1-O, and S1-C. Check RF transformer T104 and alignment.
- (13) Set control unit and signal generator controls for using test signals on the 400- to 850-kc and 850- to 1750-kc ranges. For each test signal, set BFO-OFF to BFO and tune for zero beat. Then set BFO-OFF to OFF and modulate signal generator output signal.
- (14) Listen for sound in headset. If low or missing on any frequency range, check alignment (para 3-14) and RF transformer T105 or T106.
- (15) For the following radiofrequency tests, set control unit function switch to LOOP, GAIN control fully clockwise, and range switch to 190- to 400-kc range. Tune to 200 kc.
- (16) Using 50-ohm probe, connect signal generator output to the base of second RF amplifier Q3 (figs. 2-8 and 2-10 or 2-10.1).
Set signal generator for an unmodulated 200-kc output signal at a level of 50 microvolt.
- (17) Set control unit BFO-OFF switch to BFO and tune for zero beat. Then set BFO-OFF switch to OFF. Modulate signal generator 30 percent at 400 cps.
- (18) Listen for audio in headset. If low or missing, check transistor Q3 and associated circuit components.
- (19) Using 50-ohm probe, apply signal generator output signal to the base of first RF amplifier Q1 (figs. 2-8 and 2-9 or 2-9.1) Set signal generator for an output of 100 microvolt.
- (20) Listen for audio in headset. If low or missing, check transistor Q1 and associated circuit components. Check condition of switch contacts on wafers S1-D and S1-E. Check coils and associated components in 90-degree phase-shift network between switch wafers S1-D and S1-E.
- (21) Setting control unit and signal generator controls accordingly, listen for audio on the other two frequency ranges. If weak or missing, check switches and 90-degree phase-shift network.
- (22) Connect signal generator to input of test set (fig. 2-2). Do not use 50-ohm probe. Tune signal generator for a 200-kc unmodulated output signal at a level of 100 microvolt.
- (23) Set test set GONIO DRIVE switch to OFF. Adjust loop simulator control for an indication on the LOOP SIMULATOR that is 90 degrees more than the indication on the test set BEARING INDICATOR.
- (24) Set control unit function switch to ANT. Set BFO-OFF switch to BFO and tune signal generator for zero beat in headset. Set BFO-OFF to OFF and set function switch to ADF. Modulate signal generator output, signal 30 percent at 400 cps.

- (25) If audio output is low or missing, check condition of switch contacts on wafers S1-F and S1-G. Check RF transformer T1 and associated circuit. Check RF resolver B3.
- (26) Setting control unit and signal generator controls accordingly, listen for audio on the other two frequency ranges. If weak or missing, check RF transformer T2 or T3, and resolver B3.
- (27) Remove ground from agc test point TP3. Adjust variable resistor R90 as outlined in paragraph 3-17.

2-7. Stage-Gain Measurements

Use the techniques given in a through j below when either the receiver audio is abnormally low, or the bearing indicator has a slow response.

a. General Instructions. Connect the receiver and control unit to Test Set, Direction Finder Set AN/ARM-93 as shown in figure 2-2 and outlined in paragraph 2-6b (1). Unless otherwise instructed, do not connect RF Signal Generator AN/URM-25 to the test set. In addition to the test set and RF signal generator, Multitester ME-26/U and Audio Oscillator TS-382/U are also required for these tests. Verify operation of the test equipment by performing the steps outlined in the operation and maintenance sections of the technical manuals covering the test, equipment being used. Record the output level of the signal generator for each test and determine the gain of each stage. Stage gain is computed by dividing the input signal voltage applied to the following stage by the input voltage applied to the stage under test. Some transistor stages in various circuits of the receiver contribute little if any gain and in some instances a loss in gain. These stage gains or losses are shown in charts included in the following stage-gain measurement procedures. Use the main schematic diagram (fig. 5-10 or 5-10.1)

in conjunction with the parts location illustrations referred to.

b. Audio Amplifier Stages (figs. 2-3 and 2-4). Using a 10-microfarad coupling capacitor, connect the audio oscillator output between

chassis ground and points indicated in the *Test connection column* of the following chart. Adjust signal output put to 400 cps at a level to obtain the voltage indication specified in the *Input column*. Set vtm for measuring ac voltages in the appropriate voltage range and Connect ac probe of vtm between the points indicated and chassis ground. Compare the indications obtained on the vtm with those listed in the output column, If gain differs abnormally from that listed in the chart, use further isolating techniques (para 2-8) to determine the defective component within the stage.

Note. Turn variable resistor R82 fully clockwise. After making gain tests, adjust R82 (para 3-17).

Test connection		Volts or millivolts (rms)		Stage gain
Audio oscillator	vtm	Input	Output	
Base of Q14	Collector of Q14.	860 mv	5.2 volts	6
base of Q13	Collector of Q13.	33 mv	860 mv	26
Base of Q12	Collector of Q12.	42 mv	33 mv	0.78

c. IF Amplifier Stages (figs. 2-8 and 2-15 or 2-15.1).

Set vtm for measuring dc voltages from 0 to 5 volts. Connect positive test lead to the cathode of audio detector CR1 and negative test lead to the chassis. Turn variable resistor R90 fully clockwise. Using a jumper wire, ground agc testpoint TP3. Adjust RF signal generator for a 142.5-kc output signal, modulated 30 percent at 400 cps. Set output level to approximately 2.5 volts. Using the 50-ohm probe, connect output signal to the junction connection of network Z1 and the collector of fifth IF amplifier Q11 (labeled testpoint TP2 in fig. 5-10 or 5-10.1).

Adjust output level of signal generator until vtm indicates 5 volts dc. For this reference voltage level the signal generator RF output should not exceed 2.1 volts rms. When performing the stage gain tests in the following chart, start with the last IF amplifier stage and work back toward the mixer stage. Connect signal generator 50-ohm probe between chassis ground and points indicated in the Test connection column. For each stage-gain test, adjust signal generator output to the voltage specified in the

Input column. These voltages in the Input column are the signal voltage required to obtain an indication of 5 volts dc on the vtvm. If the voltage differ abnormally, check the IF transformers and if necessary, use further isolating techniques (para 2-8) to determine the defective component.

Test connection	Volts or milli-volts (rms)
Signal generator	Input
Collector of Q11	2.1 volts
Base of Q11	0.5 volt
Collector of Q10	3.0 volts
Base of Q10	67 mv
Collector of Q9	390 mv
Base of Q9	13.5 mv
Collector of Q8	76 mv
Base of Q8	270 uv
Collector of Q7	2.5 mv
Base of Q7	6.5 uv
Collector of Q5	110 uv

Note. After the above tests, remove ground from agc testpoint TP3. Adjust variable resistor R90 (para 3-17).

d. Mixer Stage (figs. 2-8 and 2-13 or 2-13.1).

Ground agc testpoint TP3 and turn variable resistor R90 fully clockwise. Set vtvm for measuring dc voltages from 0 to 5 volts. Connect positive test lead to cathode of audio detector CR1 (fig. 2-14 or 2-14.1) and negative test lead to receiver chassis. Set test set and control unit controls as outlined in paragraph 2-6b(1). Set RF signal generator output signal to 142.5 kc modulated 30 percent at 400 cps. Adjust output level to 6 or 7 microvolt and apply signal to the base of **first** IF amplifier Q7 (fig. 2-8). Then adjust output signal until vtvm indicates 5 volts dc. The signal generator output signal required to produce this dc voltage level should be in the range of 6.5 to 7 microvolt. Record this reference level for use in the following tests. Remove signal generator and vtvm connections.

(1) Gain of mixer at IF frequency.

- (a) With signal generator set as shown above, use the 50-ohm probe and apply 142.5-kc RF signal to the junction of C29 and contact 3 of front switch wafer S1-1 labeled TP4 in figure 5-10 or 5-10.1.
- (b) Set control unit range switch to the

190- to 400-kc range and tune to 200 kc. Set BFO-OFF switch to BFO and adjust signal generator for zero beat. Then set BFO-OFF switch to OFF

- (c) Connect vtvm to cathode of audio detector CR1. Ground agc testpoint TP3.
- (d) Adjust signal generator output level to produce an indication of 5 volts dc on the vtvm. Record the signal generator output voltage required to produce the vtvm reading of 5 volts dc.
- (e) Determine mixer gain by dividing the signal generator voltage applied to the base of Q7, to produce 5 volts dc on the vtvm as in d above, by the value obtained in (d) above.
- (f) Typical mixer gain values at various frequencies are listed in the following chart. Repeat the above procedures for the remaining frequencies listed in the **Frequency** column. If mixer gain differs appreciably from the chart, use further isolating techniques (para 2-8) to isolate the defective component. After these tests, remove the agc ground connection and adjust R90 (para 3-17).

Frequency—kc	Typical gain
200	1.1
320	1.2
390	1.2
420	1.05
650	1.0
800	0.98
950	0.77
1,350	0.77
1,750	0.77

(2) Gain of mixer at RF frequencies.

- (a) Turn variable resistor R90 fully clockwise. Ground test point TP--3.
- (b) Set RF signal generator for a 200-kc output signal at a level of 6 or 7 microvolt. Using 50-ohm probe, apply signal to the junction of C29 and contact 3 of front switch wafer S1-I labeled TP-4 in figure 5-10 or 5-10.1.

- (c) Repeat paragraph d(1) (b) through (e) above.
- (d) Typical mixer gain values at various radio frequencies are listed in the following chart. If mixer gain differs appreciably from the chart, check the alignment of mixer stage and if necessary, use further isolating techniques to determine the defective component (para 2-8). After making these tests, remove agc ground and adjust R90 (para 3-17).

Frequency--kc	Typical gain
200	0.52
320	0.50
390	0.52
420	0.72
650	0.59
800	0.54
950	0.54
1,350	0.50
1,750	0.38

e. Gain of Push-Pull RF Amplifier.

- (1) Ground IF amplifier agc test point TP-3.
- (2) Set control unit function switch to LOOP, range switch to 190- to 400-kc range, BFO-OFF switch to BFO, and GAIN control fully clockwise. Tune to 200 kc.
- (3) Connect signal generator to input of test set. Tune to 200 kc and adjust output to 100 microvolt.
- (4) Tune control unit for zero heat and then set BFO-OFF switch to OFF,
- (5) Set vtm for measuring O to 5 volts dc and connect vtm to the cathode of audio detector CR1 (fig. 2-14 or 2-14.1).
- (6) Set test set LOOP SIMULATOR dial 90 degrees from that indicated on BEARING INDICATOR or for maximum indication on vtm. Set GONI DRIVE switch to OFF.
- (i) Adjust variable resistor R90 (fig. 2-8) for an indication of 5 volts dc on vtm,
- (8) Remove signal generator from test set and apply signal to the base of RF

amplifier Q4 through the 50-ohm probe (fig. 2-8).

- (9) Set control unit function switch to ANT and BFO-OFF switch to BFO. Tune for zero beat on 200 kc and then set BFO-OFF switch to OFF.
- (11) Adjust signal generator output signal to produce an indication of 5 volts dc on vtm. Record this value of signal.
- (11) Connect signal generator output through 50-ohm probe to test point TP-4.
- (12) Adjust signal generator output to produce an indication of 5 volts dc on vtm. Divide this signal generator output level by the signal obtained in step (10). A typical gain at 200 kc is 32. Repeat (2) through (12) above for each frequency listed in the following chart, If gain differs from that listed in that chart, check the alignment (para 3-14) and, if necessary, use further isolating techniques to determine the trouble (para 2-8).

Frequency--kc	Gain
320	67
390	50
420	54.3
650	40
800	28.6
950	46.1
1,350	46.7
1,750	28.1

f. Gain of Sense Antenna Input Circuit.

- (1) Repeat e (1) through (7), Then set control unit function switch to ANT.
- (2) Tune signal generator for maximum indication of vtm, Note the output signal required to obtain 5 volts dc on vtm.
- (3) Divide the signal generator output signal determined in paragraph e (10) by the value obtained in (2) above, A typical gain figure at 200 kc is 0.05.
- (4) Repeat (1) through (3) above for the remaining frequencies listed in the following chart. If gain differs appre-

ciably from that listed in the chart, check the alignment of sense antenna input circuit. After these tests, adjust R90 (para 3-17).

Frequency—kc	Typical gain
320	0.029
390	0.014
420	0.026
650	0.022
800	0.018
950	0.065
1,350	0.034
1,750	0.06

g. Gain of Third RF Amplifier.

- (1) Repeat e (1) through (7).
- (2) Listing 50-ohm probe, apply signal generator output signal to the base of transistor Q4 (fig. 2-8).
- (3) Adjust output of signal generator for an indication of 5 volts dc on vtm. Record the signal generator required for this dc voltage level.
- (4) Using 50-ohm probe, connect signal generator output to the base of transistor Q3 (fig. 2-8). Adjust output of signal generator to obtain 5 volts dc on vtm.
- (5) Divide the signal generator output signal determined in (3) above by the value obtained in (4) above. A typical gain value for a frequency of 200 kc is 0.73. Repeat (1) through (4) above at the frequencies listed in the chart below. If gain differs appreciably than listed in the chart, use further isolating techniques (para 2-8) to determine the trouble.

Frequency—kc	Gain
320	1.60
390	1.20
420	1.30
650	1.82
800	2.14
950	0.71
1,350	0.69
1,750	0.87

h. Gain of First RF Amplifier and Phase-Shift Network.

- (1) Repeat e (1) through (7).
- (2) Using 50-ohm probe, apply signal generator output to the base of Q3 (fig. 2-8). Adjust output signal for a 5-volt dc indication on the vtm. Record output signal of signal generator.
- (3) Using 50-ohm probe, connect signal generator to the base of Q1 (fig. 2-8). Adjust output signal for a reading of 5 volts dc on vtm.
- (4) Divide value recorded in (2) above by the value obtained in (3) above. At a frequency of 200 kc, a typical gain figure is 4.6. Repeat (1) through (3) above for the remaining frequencies listed in the following chart. If gain figures differ appreciably, check transistor Q1 and associated circuit components. If necessary, use further isolating techniques to locate the defective component (para 2-8).

Frequency kc	Gain
320	9.45
390	9.66
420	9.10
650	8.15
800	8.20
950	5.90
1,350	5.90
1,750	5.15

i. Gain of Loop Antenna Input Circuit.

- (1) Repeat e (1) through (7).
- (2) Using the 50-ohm probe, connect signal generator to the base of Q1 (fig. 2-8). Adjust output of signal generator to produce an indication of 5 volts dc on vtm. Record this value of output signal.
- (3) Connect signal generator output to input of test set. Set test set LOOP SIMULATOR to 90 degrees more than indicated on BEARING INDICATOR. Set GONIO DRIVE switch to OFF. Set control unit function switch to ADF.

- (4) Adjust signal generator output level for 5 volts dc on vtvm. Divide signal level recorded in (2) above by the present output of signal generator. The gain at 200 kc should be approximately 0.008.
- (5) Repeat (1) through (4) above for the remaining frequencies listed in the following chart. If gain differs appreciably, check resolver and loop antenna input circuit.

Frequency—kc	Gain
320	0.017
390	0.026
420	0.011
650	0.022
800	0.021
950	0.02
1,350	0.023
1,750	0.032

j. *Gain of Synchronous Filter, Resolver Servo Amplifier, and 110-Cps Amplifier.* Set up the equipment as follows:

- (1) Set control unit function switch to ANT, BFO-OFF switch to BFO, range switch to 190- to 400-kc range, and GAIN control fully clockwise. Tune to 300 kc.
- (2) Adjust signal generator controls for a 300-kc output signal at a level of 50 microvolt. Connect signal generator output to test set input.
- (3) Tune control unit for zero beat in headset, then set BFO-OFF switch to OFF. Set function switch to ADF.
- (4) Set vtvm to ac measuring range and connect probe to the emitter of first agc amplifier Q16 (fig. 2-3).
- (5) Set GONIO DRIVE switch to ON. When the test set BEARING INDICATOR and LOOP SIMULATOR dials have the same indication, lock the shaft of resolver servo motor B5. Lock the shaft by stretching a rubber band around the large gear shown in figure 2-8 and a corner of the receiver chassis.

- (6) Rotate the test set LOOP SIMULATOR dial clockwise as required for an indication of 20 millivolts ac on the vtvm. If necessary, increase the signal generator output signal.
- (7) Turn variable resistor R131 (fig. 2-8) fully clockwise.
- (8) Using vtvm, measure the signal voltages at the points indicated in the following chart. If a voltage is appreciably less than indicated, check transistors and associated circuit components. After these tests, adjust variable resistor R131 (para 3-20).

Point of test	Signal voltage (rms)
Base of Q17	1.7 mv
Collector of Q17	4.0 mv
Base of Q18	4.1 mv
Collector of Q18	3.0 volts
T18-1 (primary)	2.9 volts
T18-3 (secondary)	450 mv
T18-5 (secondary)	450 mv
Red wire of B5	6.0 volts
Black wire of B5	5.6 volts
Green wire of B5	4.1 volts
Collector of Q23	4.1 volts
Base of Q23	2.0 volts
Collector of Q22	2.0 volts

2-8. Isolating Trouble Within Stages

a. *General.* When trouble has been localized to a stage through operational checks, signal substitution (para 2-6), or gain measurements (para 2-7), isolate the defective component by voltage measurements on the transistor stages (fig. 2-17). Make resistance measurements on the transformers and RF coils (para 2-9a). Make resistance measurements only where it is safe to do so without damaging low-power transistors.

Caution: Before making voltage measurements, observe notes on voltage diagram (fig. 2-17). Do not remove or insert a transistor with voltage applied to the circuit.

b. *Transistor Testing.* When trouble has been traced to a stage, test the transistor (or transistors) before making other tests. Use Transistor Tester TS-1836/U. If the transistor is wired in the circuit, try to troubleshoot the

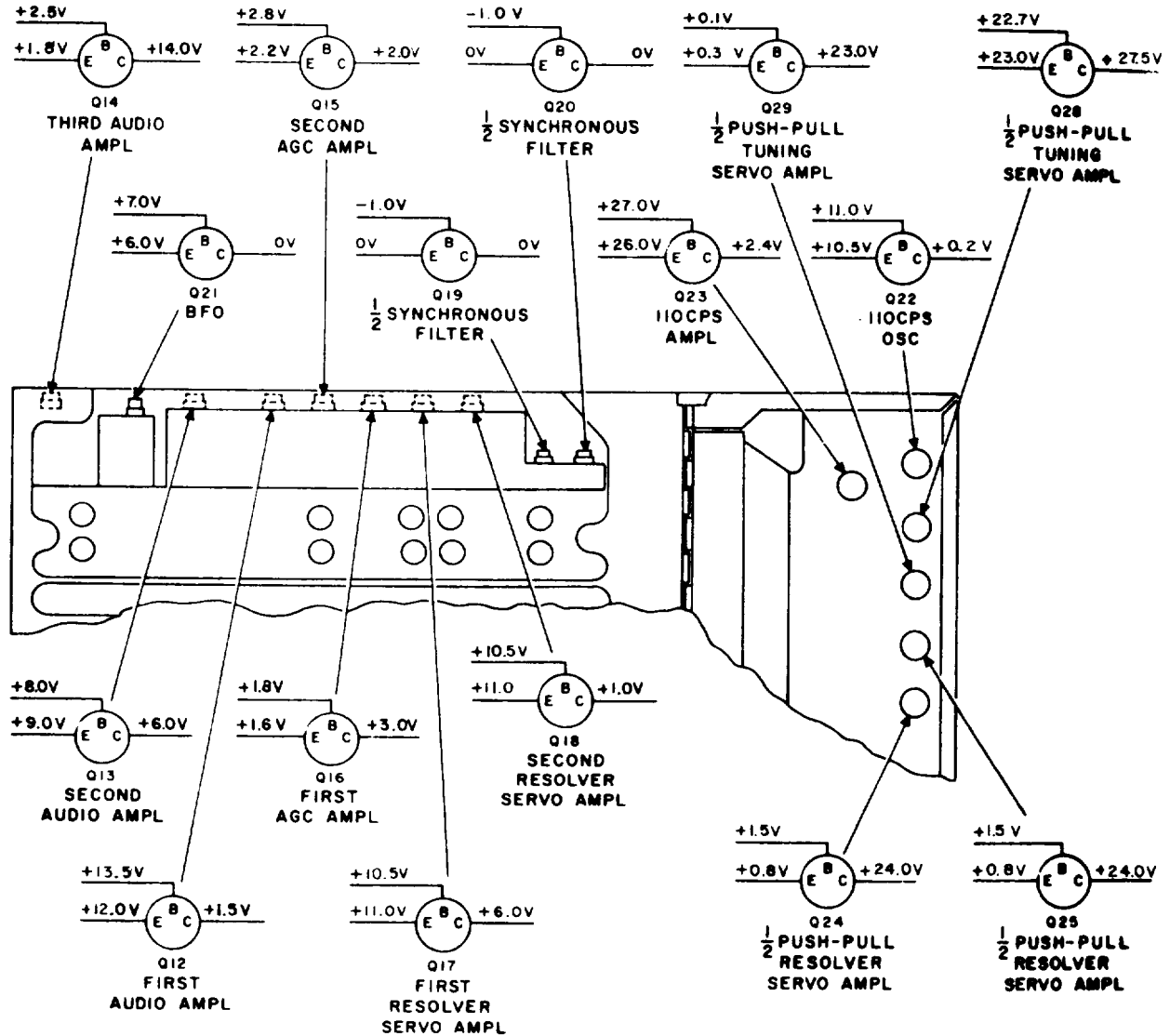

5. VOLTAGES MAY VARY ± 10%.

NOTES:

1. VOLTAGE MEASUREMENTS TAKEN WITH RECEIVER CONNECTED TO TEST SET.
2. TEST SET DC POWER SWITCH ON, FUNCTION SWITCH ON ADF, RANGE SWITCH ON 400-850 RANGE, GAIN CONTROL MAXIMUM CW, RECEIVER TUNED TO 650KC AND NO SIGNAL INPUT. FOR BFO VOLTAGE READINGS, SET BFO-OFF SWITCH TO BFO.
4. + VOLTAGE READINGS OBTAINED WITH NEGATIVE TEST LEAD OF VTVM CONNECTED TO CHASSIS AND POSITIVE TEST LEAD CONNECTED TO POINTS INDICATED.

TM5826-225-35-48 (1)

Figure 2-17 Receiver transistor voltage diagram (part 1 of 2).

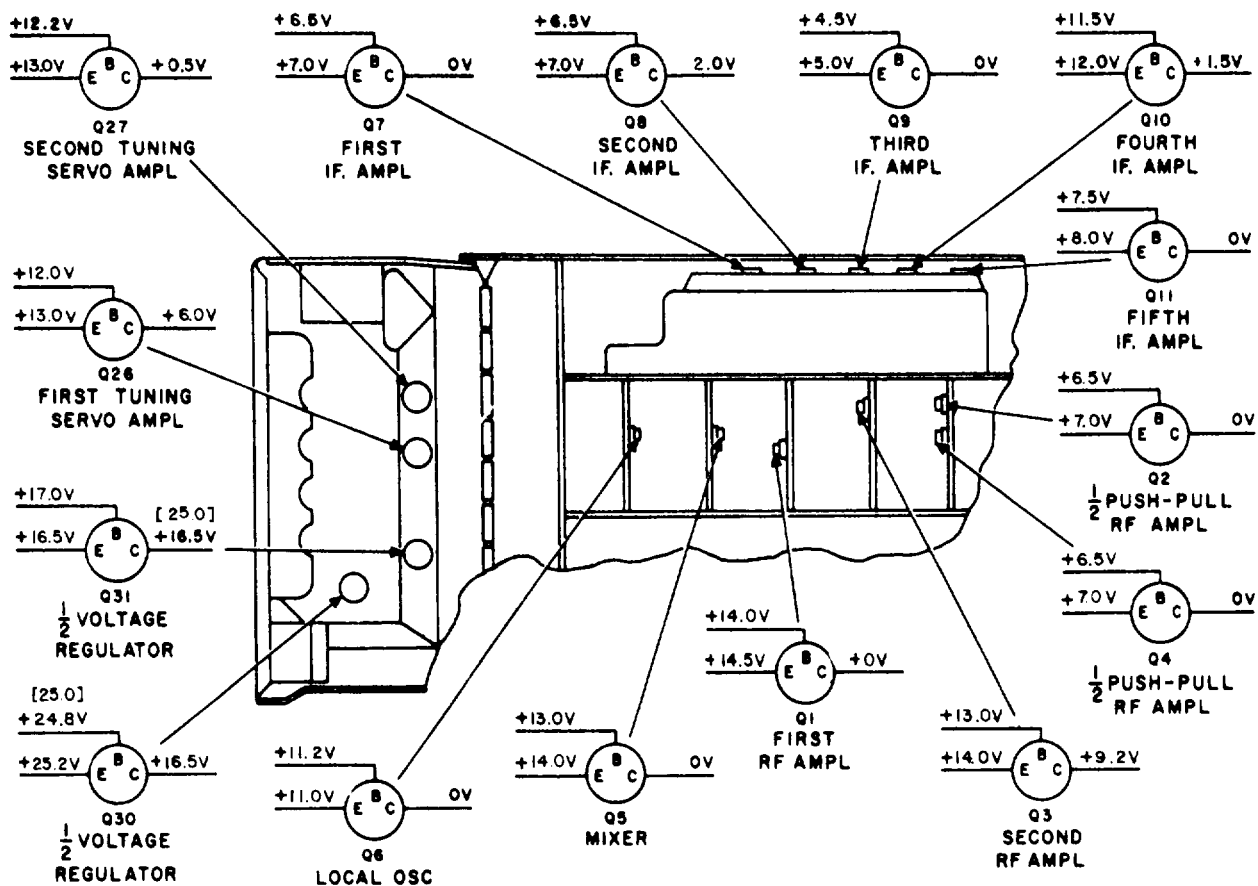

4. VOLTAGES MAY VARY $\pm 10\%$.
 5. VOLTAGES IN [] APPLY TO RECEIVER R-1391/ARN-83 (CPN 522-2587-015) ONLY.

NOTES:

- VOLTAGE MEASUREMENTS TAKEN WITH RECEIVER CONNECTED TO RADIO TEST SET.
- TEST SET **POWER** SWITCH **ON**, FUNCTION SWITCH ON **ADF**, RANGE SWITCH ON **400-850** RANGE, **GAIN** CONTROL MAXIMUM CW, RECEIVER TUNED TO 850KC AND NO SIGNAL INPUT. FOR BFO VOLTAGE READINGS, SET **BFO-OFF** SWITCH TO **BFO**.
- + VOLTAGE READINGS OBTAINED WITH NEGATIVE TEST LEAD OF VTVM CONNECTED TO CHASSIS AND POSITIVE TEST LEAD CONNECTED TO POINTS INDICATED.

TM5826-225-35-48 (2)

Figure 2-17 (2). Receiver transistor voltage diagram (part 2 of 2).

equipment without physically unsoldering the transistor leads. It requires considerable time to unsolder and resolder transistor leads. In addition, transistors can be damaged by **heat** or **accidental breaking of a lead**.

c. Weak Signals. If signals are weak and all tests fail to indicate a defective part, check the alignment of the receiver. See chapter 9.

d. In-Circuit Resistance Measurements. If transistors are the pluck-out type, make resistance measurements in these stages with the transistors removed from the sockets. When measuring the resistance of circuit elements connected across the base-emitter or base-collector junction of any wired-in transistor, consider polarity of the ohmmeter and try

measurements with the ohmmeter leads connected one way and then reverse the leads. When in doubt about the value of resistance measurements, check a receiver known to be in good operating condition. Since all low-power transistors of the pluck-out type operate on very low voltages, a capacitor seldom causes trouble. If an IF transformer is suspected of having an open winding, remove the associated transistor before making resistance measurements. For all resistance measurements, use Multimeter TS-352/U. Set multimeter on the RX100 range.

Caution: If the receiver is inoperative in all operating modes (no sound or bearing indication) and a shorted voltage regulator filter capacitor is suspected, check the resistance of capacitors C88, C116, and C146 (figs. 2-6 and 2-7) before applying power.

e. Voltage Measurements. Make voltage measurements in accordance with figure 2-17. Transistors in the push-pull RF amplifier, oscillator, bfo, and IF amplifier have collector load impedances which present the proper load at the resonant frequency but present such a low dc resistance that no collector voltage can be measured. In these transistor stages, a slight shift in transistor characteristics may change emitter and base-bias voltages from that indicated in figure 2-17. If this occurs, try another transistor. When making voltage measurements, use Multimeter ME-26/U or a vtvm with equivalent characteristics,

f. Waveforms. Using Oscilloscope AN/USM-140, make waveform checks and compare them with the waveforms given in figure 2-18. Waveform checks will help to isolate trouble in the balanced modulator, synchronous filter, agc circuit, and the servo amplifiers. Do not connect the oscilloscope directly to the transistor pins or wires. Use a low capacity probe.

g. Illustrations. Use the main schematic diagram (fig. 5-10) in conjunction with the stage and interunit schematic diagrams to circuit trace and isolate the faulty part. For parts location, refer to figures 2-3 through 2-16.

2-9. Additional Troubleshooting Data

a. Dc Resistances of Transformers and Coils.

The dc resistances of transformers and coils are given in the chart below.

Transformer or coil	Terminals	Ohms
T1 -----	1-2	9
	2-3	2
	4-5	2
	5-6	2
T2 -----	1-2	18
	2-3	3
	4-5	2.1
	5-6	2.5
T3 -----	1-2	8
	2-3	1.6
	4-5	2
	5-6	2.2
T10 -----	1-2	36
	3-4	4.4
T11 -----	1-2	10.4
	3-4	2.3
T12 -----	1-2	4.6
	3-4	1.8
T13 through T17 -----	1-2	5.5
	3-4	1
T18 -----	1-2	1,500
	3-4	59
	4-5	59
T19 -----	1-2	2,000
	3-4	150
	5-6	150
T20 -----	1-2	90
	3-4	300
	4-5	300
T104 -----	1-2	26
	3-8	Infinity
	7-8	Infinity
	4-5	Less than 1
	5-6	Less than 1
T105 -----	1-2	7.2
	3-8	Infinity
	7-8	Infinity
	4-5	Less than 1
	5-6	Less than 1
T106 -----	1-2	26
	3-8	Infinity
	4-5	Less than 1
	5-6	Less than 1
	7-8	Infinity
T107 -----	1-2	32
	3-4	4.2
	4-5	4.3
T108 -----	1-2	10
	3-4	1
T109 -----	4-5	1
	1-2	4.8
	3-4	1
	4-5	1.2

Transformer or coil	Terminals	Ohms
L1 -----		26
L3 -----	1-2	28
	2-3	2.1
L4 -----	1-2	19
	2-3	1.4
L5 -----	1-2	6.4
	2-3	Less than 1
L6 -----		16
L8 -----		Less than 1
L11 -----	1-2	54.5
L12 through L15 -----		46
L16 -----		62
L17 -----		10
L18 -----		Less than 1
L22 -----		16
L24 -----		26
L25 -----		1.8
L26 -----		Less than 1

Transformer or coil	Terminals	Ohms
L27 -----		6.9
L28 -----		3.7
L29 -----		2.5
L30 -----		1.2
L31 -----		2.6

b. Typical System Troubles Caused by Defective Receiver. The following chart lists symptoms that indicate improper equipment performance. The chart also lists a probable cause in the receiver for each of these symptoms. This chart does not include all probable causes in the receiver for a given symptom, or probable causes in other components or in the aircraft wiring.

Item	Symptom	Probable Cause
1	Tuning servo has a slow response and will not reach a null.	Capacitor C74 coupled to control winding of tuning servo motor MGI changes value.
2	On the 190- to 400-kc range, radio station frequency does not agree with dial calibrations of control unit.	Capacitor C37 in local oscillator circuit defective.
3	Spurious frequencies on all frequency ranges _____	Local oscillator Q6 defective.
4	BFO inoperative -----	Capacitor C99 in bfo circuit defective. RF coil L16 open.
6	Bearing indicator will not reach null in adf mode	Bypass capacitor C82 (selected) on T18-1 defective.
6	Low sensitivity in adf mode _____	Push-pull RF amplifiers Q2 and Q4 defective. Resolver B3 defective.
7	Loop and adf modes inoperative ... _____	Shorted winding in T18. The 110-cps oscillator Q22 or f lo -cps amplifier Q23 defective. Emitter bias resistor R122 on Q23 defective by reason of capacitor C67 king shorted.
8	Intermittent operation in loop and adf modes ----	Bypass capacitor C5 on T1, T2, and T3, defective. Emitter bypass capacitor C6 on first RF amplifier Q1 defective.
9	Bearing indicator pointer erratic on tail bearings	Capacitor at junction of emitter bias resistor R31 and base-bias resistor R30, defective (fourth IF amplifier Q10).
10	In ADF mode bearing indicator either has a slow response or is inoperative.	Resolver servo motor B5 has insufficient torque. Second RF amplifier Q3 defective. Q17 bias adjust variable resistor R131 out of adjustment.
11	Homing function weak and will not reach aural null in loop mode.	Filter capacitor C146 in voltage regulator circuit defective. Second audio amplifier Q13 defective. Audio coupling capacitor C83 defective.
12	Inoperative in all mode. _____	Emitter bias resistor R107 on second IF amplifier Q8 defective.
13	In loop mode: (a) Bearing indicator rotates too slow when control unit LOOP switch is in slow slew position. (b) Bearing indicator rotates too fast when control unit LOOP switch is in slow slew position, and/or indicator rotates too slow when control unit LOOP switch is in fast slew position,	(a) Resolver servo-amplifier bias resistor R133 (selected) has too low a value. Capacitor c82 (selected) defective (b) Resolver, servo-amplifier bias resistor R133 (selected) has 100 high a value.
14	No manual control of RF gain ---;-----	Rf coil L12 Open.
16	Audio output signal present when control unit GAIN control is in full counter-clockwise position.	Diode CR11 in voltage regulator circuit oscillating.
16	Little or no audio output -----	Capacitor C78, connected between terminals 3 and 6 of T20, defective.

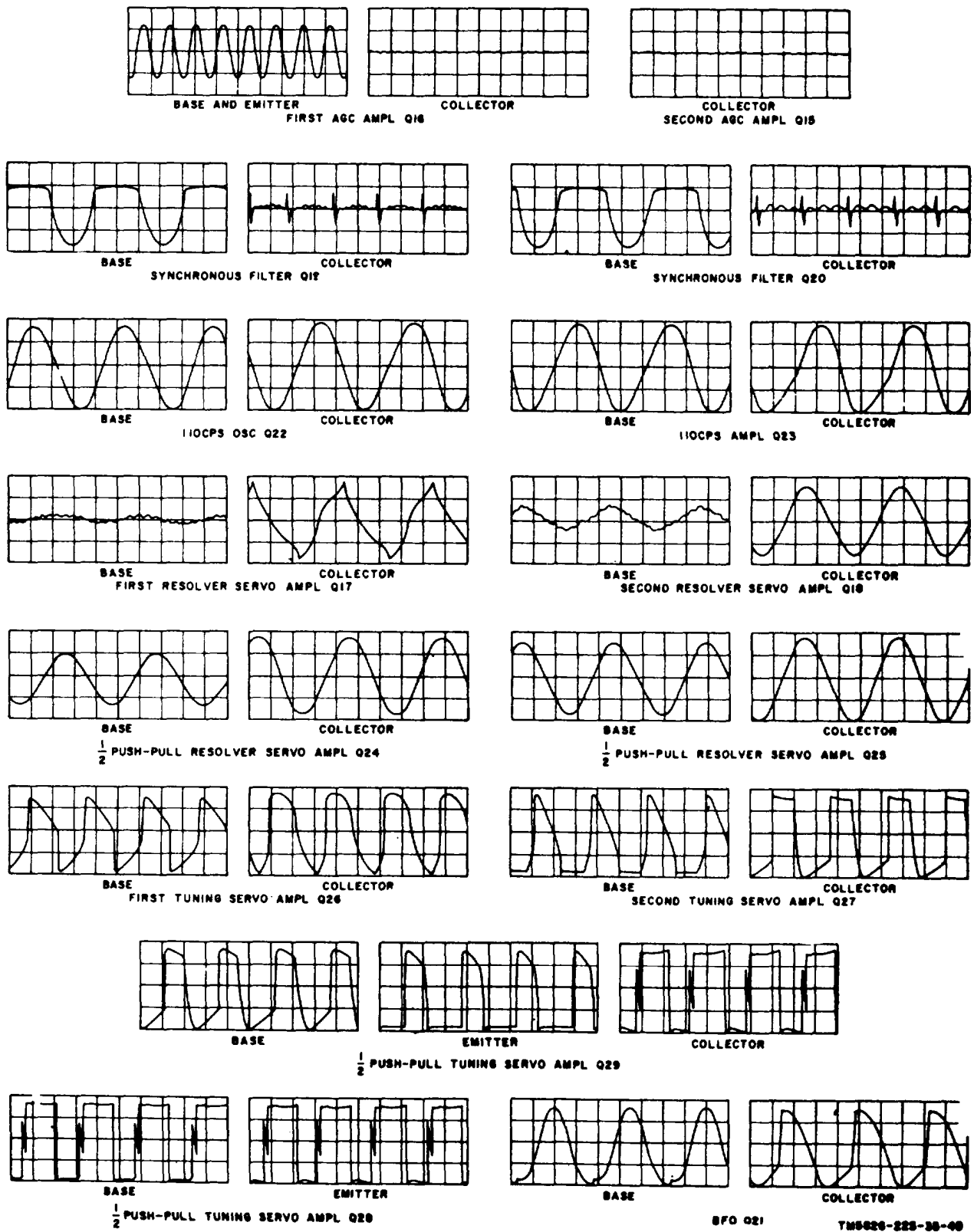

Figure 2-18. Receiver waveforms.

c. **Receiver Waveforms.** Typical waveforms at significant points in the receiver are shown in figure 2-18. Use oscilloscope AN/USM-140 when obtaining data for comparison with the waveforms shown in figure 2-18. The waveforms in figure 2-18 were obtained under the following conditions:

- (1) The receiver and the 27.5-vdc power source are connected to Test Set, Direction Finder Set AN ARM-93 as shown in figure 2-2.
- (2) The test set controls are set as follows:

Control	Position
DC POWER	ON
GONIO DRIVE	ON
RECEIVER-CONTROL	RECEIVER
Function switch	ADF
Range switch	190-400
TUNE	200 kc on FREQUENCY indicator
GAIN	As required
BFO-OFF	OFF (except for Q21)

- (3) The 150PF-270PF control on the sense antenna adapter is set to 150PF.
- (4) The oscilloscope horizontal speed is adjusted to obtain a waveform similar to that shown in figure 2-18.
- (5) Except for bfo Q21, waveform data is taken with Rf Signal Generator AN URM-25() connected to the test set as shown in figure 2-2. The AN URM-25() is tuned for 200 kc (set BFO-OFF switch on the test set to ON and tune AN/URM-25() for a zero beat in the headset, then set BFO-OFF switch to OFF). The AN URM-25() output is then adjusted for 1,000 microvolts, modulated 30 percent at 400 cps.
- (6) For bfo Q21, do not connect RF Signal Generator AX URM-25() and set the BFO-OFF switch on the test set to OFF.
- (7) Waveform data on Q17, Q18, Q24, an Q25 is obtained with servo motor B5 locked. After B5 is locked, by blocking the gear train, adjust the loop simulator control on the test set for an indication on the LOOP SIMULATOR that is 90 degrees greater than the indication on the BEARING INDICATOR.
- (8) Waveform data on Q26, Q27, Q28, and Q29 is obtained with servo motor-generator set MGI locked. After MGI is locked, by blocking the gear train, change the TUNE control on the test set to 300 kc.

Section III. TROUBLESHOOTING DIRECTION FINDER CONTROL C-6897, ARN 83

2-10. Test Setup

All troubleshooting tests made on the control unit are conducted with Test Set, Direction Finder Set AN ARM-93 and Multimeter TS-352 U. No other equipment is required. After ~~the test set and the control unit~~ under test. Make the test setup as illustrated

in figure 2-19. Unless otherwise indicated in the following tests, do not connect the multimeter to the test set.

2-11. Test Procedure

To remove the control unit dust cover, loosen the two quarter-turn screws at the rear. For parts location, refer to figures 2-20, 2-21, and 2-22. Figure 5-11 is a schematic diagram of the control unit.

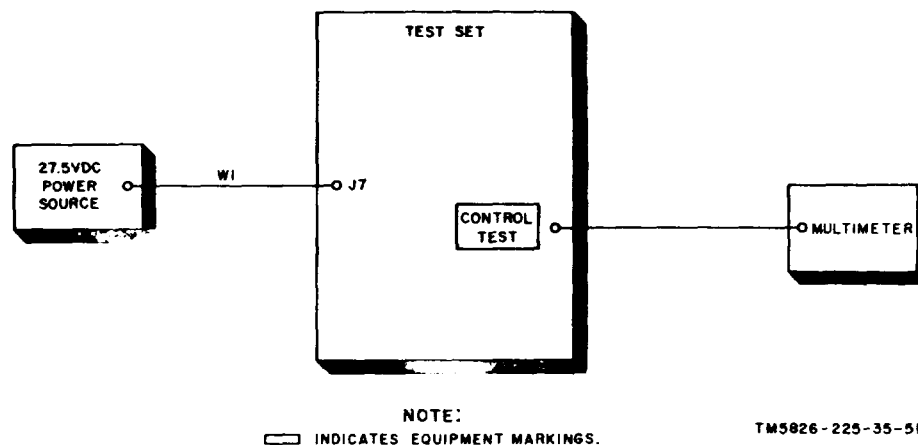

Figure 2-19. Control unit test setup.

a. *Tuning Meter Test.* Set test set RECEIVER-CONTROL switch to CONTROL and CONTROL TEST switch to position 1. Set DC POWER switch to ON. The tuning meter on the control unit under test should indicate half scale and the panel and dials should be illuminated. If the tuning meter indicates otherwise or is inoperative, tuning meter M301 (fig. 2-20) is defective.

b. *Tuning Synchro Test.*

(1) Set control unit function switch to the ADF mode.

(2) Set control unit range switch to the 850-1750 position, Tune control unit to 850 kc. The test set BEARING INDICATOR pointer should indicate 343 ± 1 degree.

(3) Tune control unit until the FREQUENCY dial hairline bisects the small zero between 1,400 and 1,500 kc, The test set BEARING INDICATOR should indicate 239 ± 1 degree,

(4) Tune control unit to 1700 kc. The BEARING INDICATOR should indicate 203 ± 2 degrees.

(5) If the BEARING INDICATOR pointer indication does agree with the normal indications obtained in the above tests, either tuning synchro B301 is

defective or the dial and synchro are out of alignment.

c. *Resistance and Continuity Tests.*

(1) Set test set DC POWER switch to OFF. Connect test leads of multimeter to the two panel connectors on the test set marked CONTROL TEST and set multimeter to the RX 1 ohms range.

(2) Set test set CONTROL TEST switch to position 1. The multimeter should indicate zero ohms.

(3) Set multimeter to the RX10 range. Turn control unit LOOP control to the first position left and right. The multimeter should indicate 4,700 ohms for both low speed positions of the LOOP control.

(4) If the multimeter indications are not as specified in (2) and (3) above, LOOP switch S303 is defective.

(5) Set test set CONTROL TEST switch to position 2, With the BFO-OFF switch in OFF position, the multimeter should indicate infinity. Set BFO-OFF switch to BFO. An ohmmeter reading other than zero indicates that BFO-OFF switch S301 is defective,

(6) Set CONTROL TEST switch to position 3. Set control unit function switch to ADF. The multi meter

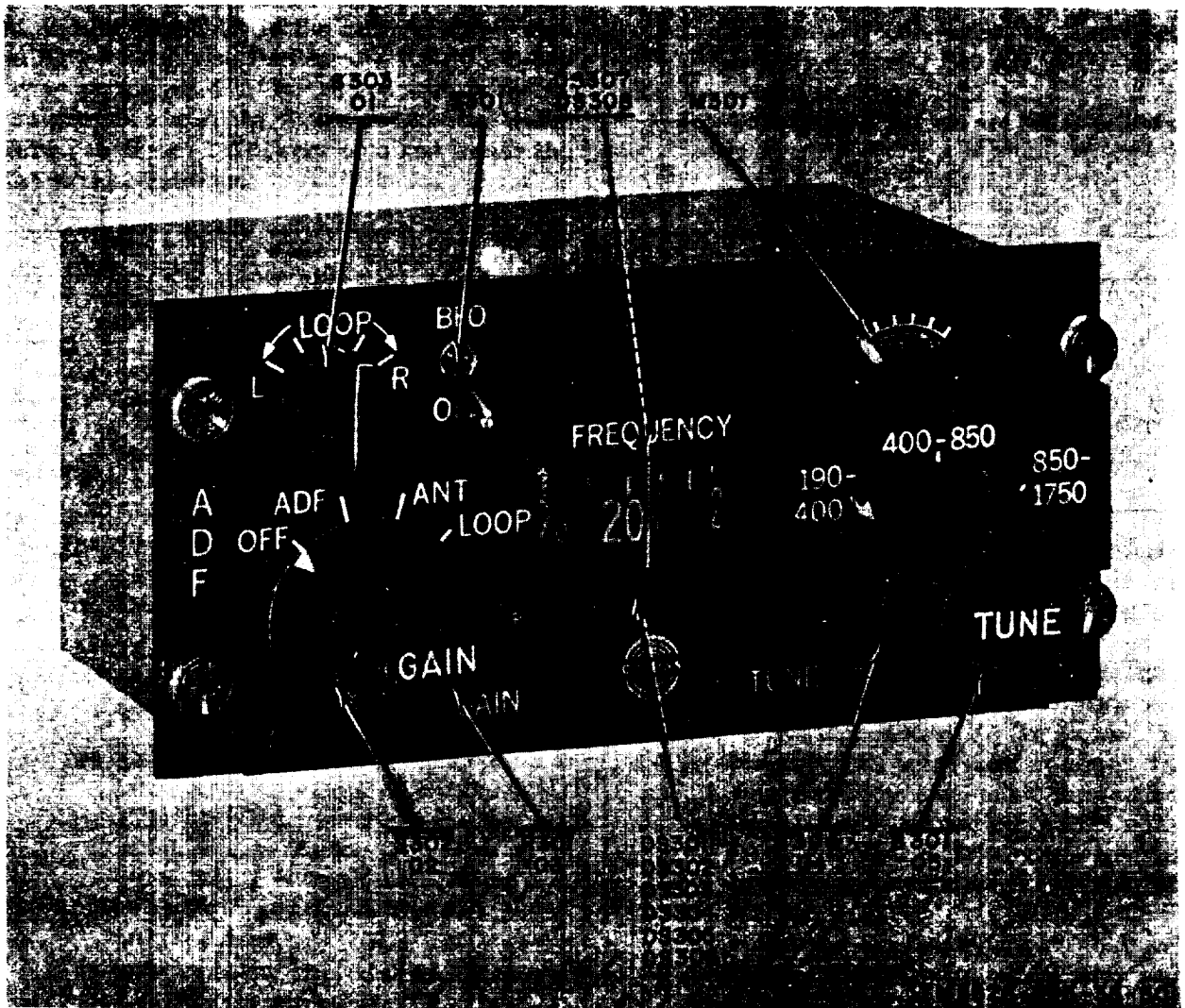

Figure 2-20. Control unit, front view.

- should read zero ohms. A reading other than zero ohms indicates that function switch wafer S302-A is not making contact.
- (7) Set function switch to ANT and LOOP positions. The multimeter should indicate from 5,000 ohms to zero ohms as the GAIN control is turned clockwise. A multimeter reading other than the above indicates either that function switch wafer S302-A or RF gain variable resistor R301-C is defective.
 - (8) Set CONTROL TEST switch to position 4. Turn control unit GAIN control fully counterclockwise. With the function switch in either ADF or ANT position, the multimeter should read 5,000 ohms which is the resistance of variable resistor R301-C.
 - (9) Set function switch to LOOP. A multimeter reading much different than 5,470 ohms indicates that resistor R303 in series with R301-C is defective.
 - (10) Set CONTROL TEST switch to posi-

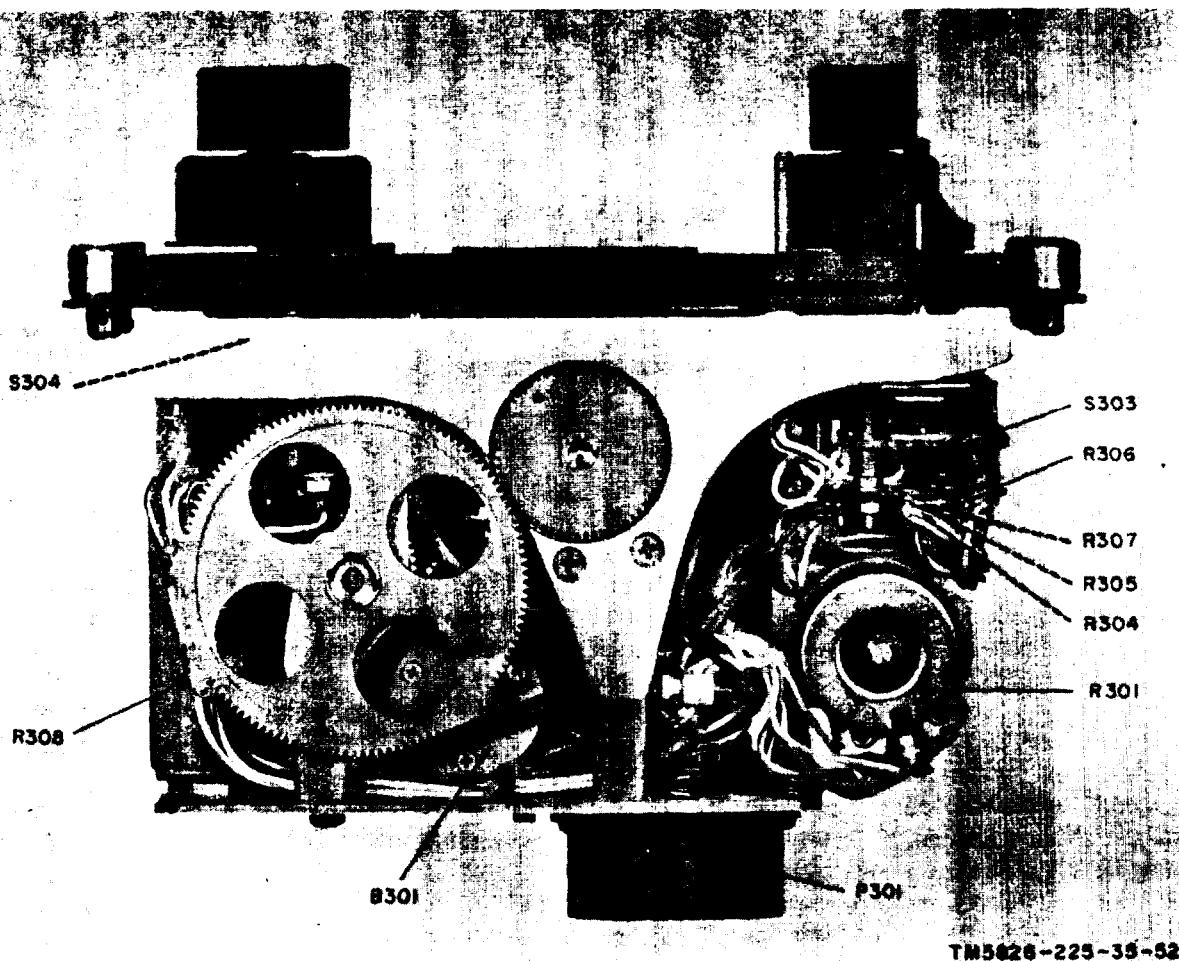

Figure 2-21. Control unit, top view.

tion 5 and set function switch to ADF. As the GAIN control is rotated clockwise, the multimeter should indicate from 600 ohms to zero ohms. A multimeter reading other than specified indicates trouble in the bridged T-attenuator comprising R301-A, R301-B, R304, and R305.

- (11) Set function switch to either LOOP or ANT position. The multimeter should indicate zero ohms. Any other reading indicates that function switch wafer S302-A is not making contact.
- (12) Set CONTROL TEST switch to position 6 and function switch to either

ANT or LOOP position. The multimeter should read infinity. With the function switch set to ADF, the multimeter should read approximately 650 ohms for any GAIN control setting or R301-A and R301-B.

- (13) Set CONTROL TEST switch to position 7 and set function to ADF, ANT, or LOOP position. The multimeter should indicate zero ohms. Set function switch to OFF. The multimeter should read infinity.
- (14) Set CONTROL TEST to position 8. The multimeter should read infinity with the function switch set to OFF

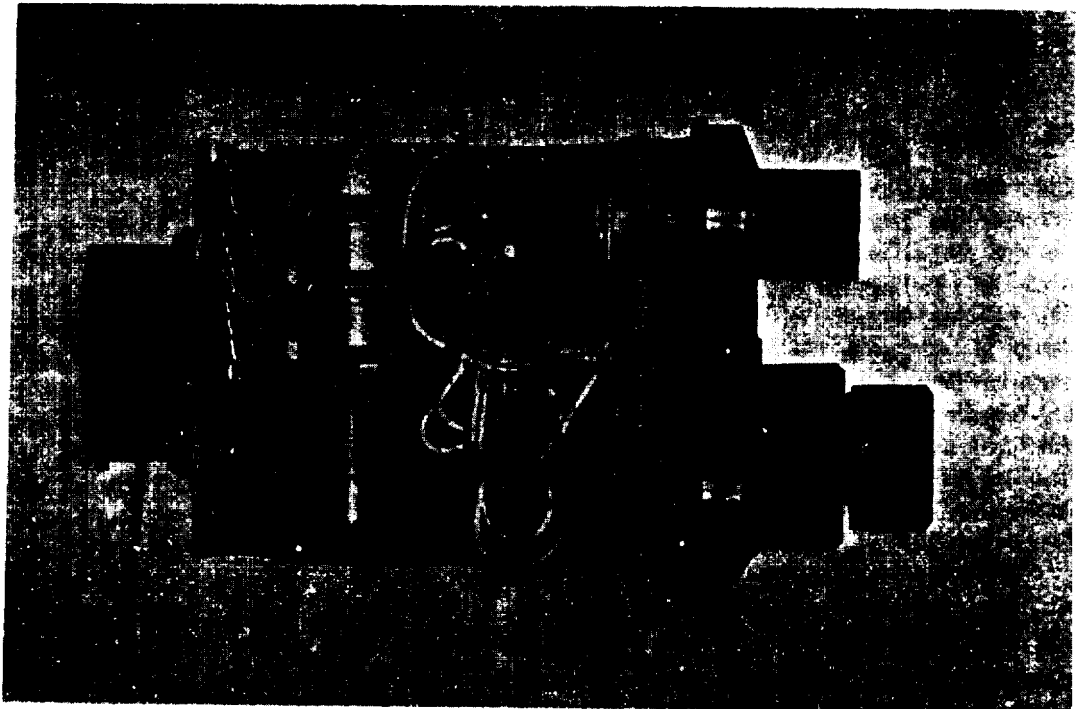

Figure 2-22. Control unit, left side view.

- and ADF positions and indicate zero ohms for LOOP and ANT positions.
- (15) Set CONTROL TEST switch to position 9. The multimeter should indicate zero ohms with the function switch set to ADF or LOOP position and infinity for OFF or ANT position.
- (16) Set CONTROL TEST switch to position 10. The multimeter should indicate infinity with the function switch set to OFF or LOOP position and zero ohms for ADF or ANT positions.
- (17) If the test results are not as specified in steps (13) through (16), function switch S302 is defective.
- (18) Set CONTROL TEST switch to position 11. The multimeter should indicate 25 ohms with the control unit range switch set to the 190- to 400-kc position and zero ohms for the other two ranges.
- (19) Set CONTROL TEST switch to position 12. The multimeter should indicate 25 ohms with the range switch set to the 400- to 850-kc range and zero ohms for the other two ranges.
- (20) Set CONTROL TEST switch to position 13. The multimeter should indicate 25 ohms with the range switch set to the 850- to 1750-kc range and zero ohms for the other two ranges.
- (21) If the test results are not as specified in steps (18) through (20), either range switch S304 or resistor R308 is defective.

2-12. Localizing Troubles

If any local resistance measurements are necessary after using the test set, refer to **disassembly and reassembly procedures in chapter 3.**

Section IV. TROUBLESHOOTING MOUNTING MT-3605/ARN-83 AND INVERTER, POWER, STATIC CV-2128/ARN-83

2-13. Test Setup

The only troubles that can occur in the receiver mount are damage to connectors (J1 and J2 of fig. 2-24) and aircraft wiring connections to the receiver mount. Therefore, the remainder of this section will be devoted to the inverter. All tests on the inverter require connections to Test Set, Direction Finder Set AN/ARM-93 and the source of 27.5-volt dc power used for testing the receiver and control unit. After making certain the test set DC POWER switch is set to OFF, remove the plate at the top of the test set front panel marked INVERTER. Loosen the two retaining screws on the inverter supplied with the test set and remove the inverter.

a. Remove the inverter mounted in Mounting MT-3605/ARN-83 (fig. 2-24).

b. Connect one end of the test set cable W4 to the test set and the other end to connector PI on the inverter (fig. 2-25). The length of the cable will permit bench tests on the in-

verter. The inverter test setup is illustrated in figure 2-23.

2-14. Localizing Troubles

a. Set test set DC POWER switch to ON and allow 5 minutes for inverter warmup. The other test set controls may be in any position.

b. Set controls on Multimeter ME-26/U (vtvm) to a range suitable for measuring 26 volts ac. Connect the common test lead of vtm to a convenient ground on the test set front panel. Insert the tip of the vtm ac test probe into the center of the test set panel fuse holder marked 1A. The voltage should be 26 ± 2.0 volts **ac**.

c. Set TIME UNIT switch of Frequency Meter AN/USM-26 (counter) to IKC, FUNCTION SELECTOR to FREQUENCY, and STD. GATE TIME SEC. switch to 1 second. Connect ground lead of counter to a ground on the test set front panel. Connect SIGNAL INPUT of counter to the fuse holder specified in *b* above. The counter frequency read out should be 400 ± 40 cps.

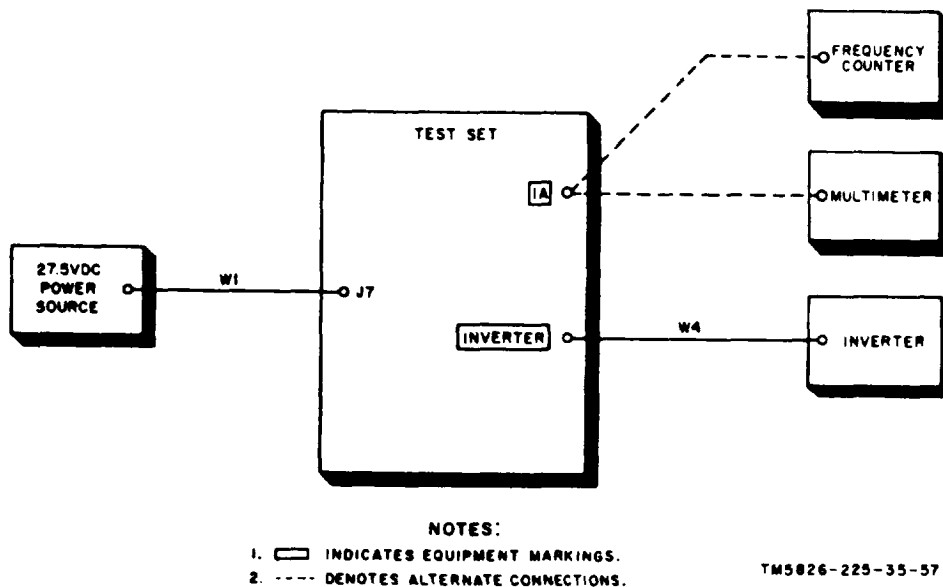

Figure 2-23. Inverter test setup.

2-15. Isolating Trouble Within Stage

If the trouble has **been** traced to the inverter through the checks made in paragraph 2-14, use the following techniques to isolate the stage *or* part at fault.

a. Test the transistors with Transistor Tester TS-1836/U (figs. 2-25 and 2-26).

b. **Make voltage measurements** on the transistors and compare them with those given in **figure 2-27**. Refer also to the dc resistance of transformers and coils (d below).

c. If necessary, adjust R1 for 26 ± 2.0 volts ac.

d. Dc resistances of transformers and coils.

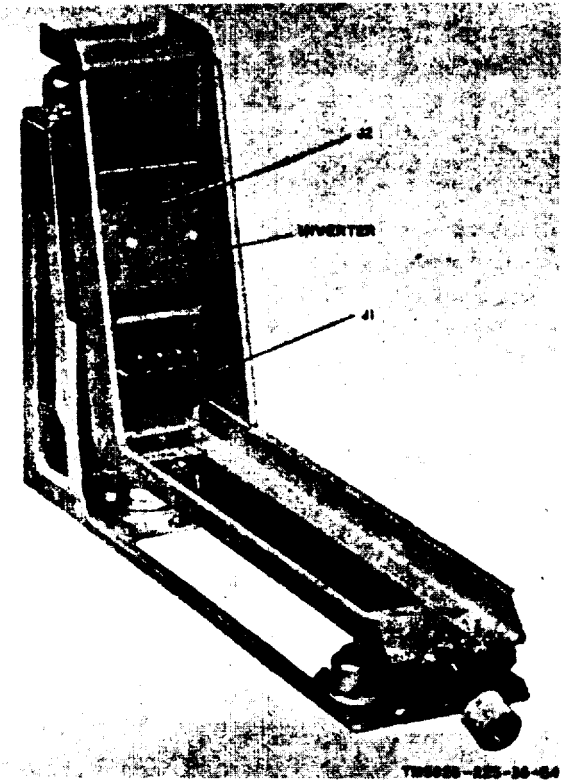

Figure 2-24. Mounting with inverter installed.

Transformer or coil	Terminals	Ohms
L1	YEL-GRN GRN-BLK	25
T1	1-2	9
	2-3	2
	4-5	2
	5-6	2

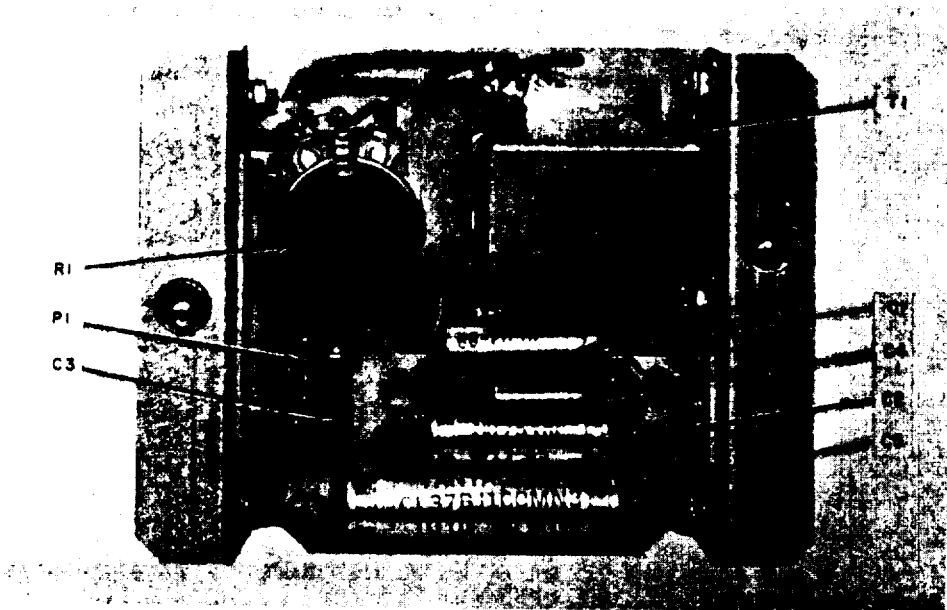

Figure 2-25. Inverter, bottom view.

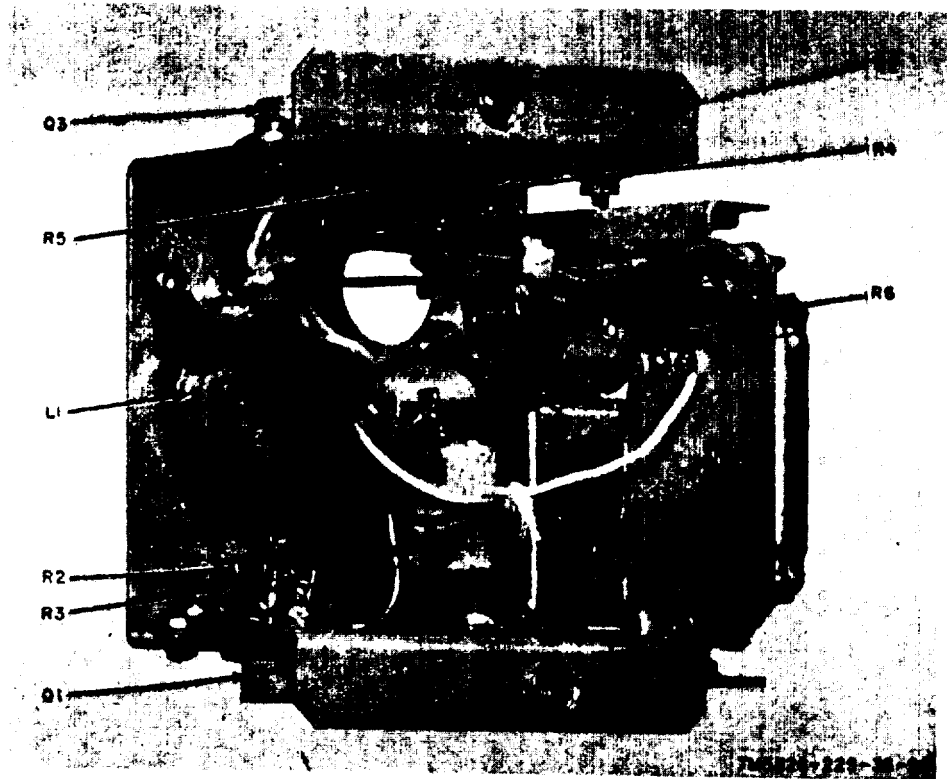
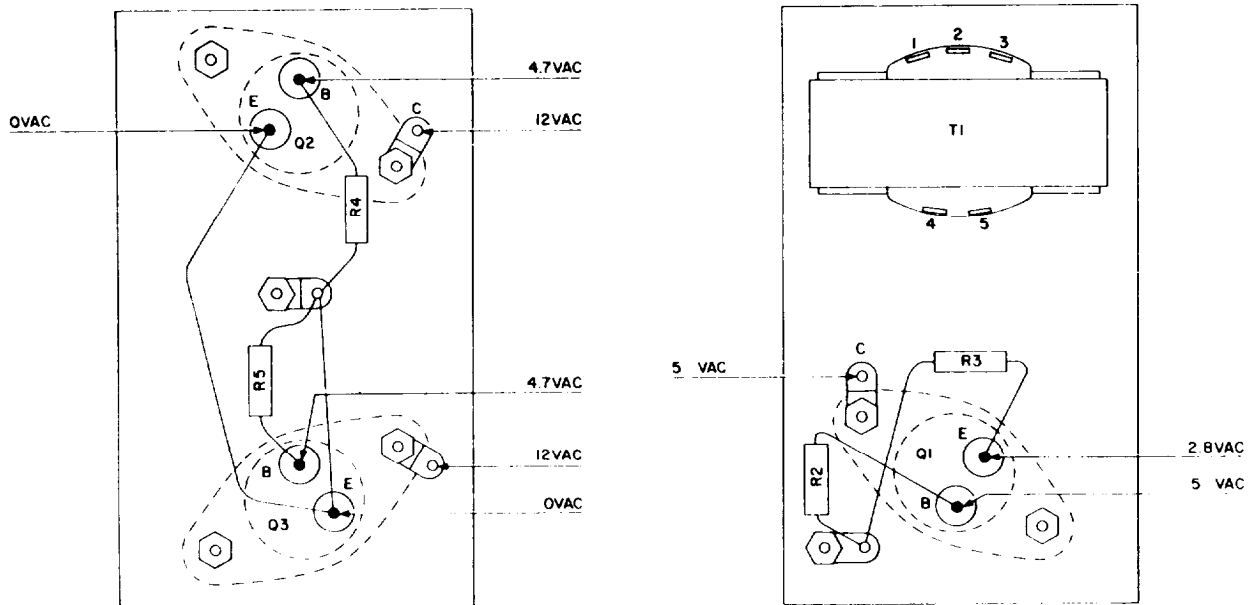

Figure 2-26. Inverter, end view.



NOTES

1. VOLTAGE MEASUREMENTS TAKEN WITH INVERTER CONNECTED TO TEST SET
2. TEST SET **DC POWER** SWITCH TO **ON** AND **RECEIVER-CONTROL** SWITCH TO **CONTROL**
3. ALL VOLTAGES ARE MEASURED FROM CHASSIS GROUND.

TM5826-225-35-58

Figure 2-27. Inverter voltage diagram

Section V. TROUBLESHOOTING ANTENNA AS-1863/ARN-83

2-16. Test Setup

Troubleshooting Antenna AS-1863/ARN-83 consists of **measuring the Q** of the loop coils using 'Q Meter TS-617/U and the loop test fixture supplied with Test Set, Direction Finder Set AN/ARM-93. The loop antenna test setup is shown in figure 2-28.

a. Mount Q Meter TS-617/U on the four large banana plugs (P2 through P5) of the **test set loop test fixture**. Connect J1 of the loop antenna to **connector P1** of the loop test fixture.

b. Set the loop test fixture selector switch to position 1.

c. Set controls of Q meter for a frequency of 1.0 megacycle. Adjust capacity control for maximum Q. The capacity required for maximum Q should be 140 to 280 picofarads.

d. Set test fixture switch to position 2.

e. Using the same frequency as in c above, adjust Q meter capacity control for maximum Q. The capacity required for maximum Q should be 140 to 280 picofarads.

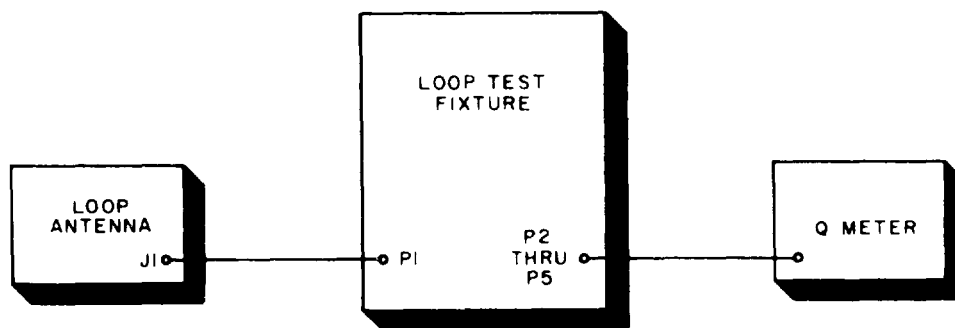

TM5826-225-35-59

Figure 2-28. Loop antenna test setup.

CHAPTER 3

REPAIRS AND ALIGNMENT

Section 1. REPAIRS

3-1. General Parts Replacement Techniques

The following general precautions should be observed when replacing parts in this equipment.

a. When soldering or unsoldering transistor leads or precision resistors, solder quickly to allow as little heat conduction as possible. Whenever wiring permits, use a heat sink (such as a long nose pliers) between the solder joint and the part. Use approximately the same length and dress of leads as used originally.

b. Use a pencil-type iron with a 25-watt maximum capacity when working on replacement of non pluck-out transistors. If the iron must be used with ac, use an isolation transformer between the iron and the line. Check soldering irons for shorts to the iron tip before using. Do not use a soldering gun as damaging voltages can be induced in components.

c. In some cases power transistors are mounted on heat sinks. When replacing power transistors, always replace the insulating washer between the transistors and the heat sink if an insulator is used. Before installing the mica or fiber washers, treat them with a film of silicone fluid or equivalent to help in the transfer of heat. After the transistor is mounted and before making connections, check from transistor case to ground for effective insulation.

d. Whenever an electrical part **such as a** resistor, capacitor, or a coil is to be removed, note the exact position of the part before removing it. Replace the part in the same position.

e. When tightening the two setscrews in a collar-type clamp, the setscrews must be tightened against the center of the gear (or other mechanical part) quarter segments.

3-2. Removal and Replacement Techniques

The procedures for removing receiver sub-assemblies and disassembling the receiver gear train subassembly are described in paragraph 3-3. The corresponding reassembly and replacement procedures are described in paragraph 3-4. Paragraph 3-4 also includes instructions for lubrication that is performed during receiver reassembly and replacement. The procedures for disassembling the control unit are described in paragraph 3-5. Reassembly and lubrication that is performed during reassembly of the control unit are described in paragraph 3-6. The loop antenna cannot be disassembled and disassembly of the inverter and receiver mount are obvious,

3-3. Disassembly of Receiver

a. *Removal of Dust cover.*

- (1) Loosen two screws (fig. 2-1) at front of the receiver and one screw at rear.
- (2) Pull off dust cover.

b. *Removal of Power Supply and Servo Compartment.*

- (1) Remove four screws (A, fig. 3-1).
- (2) Swing out power supply and servo compartment.
- (3) Remove four screws (A, fig. 3-2), and remove the compartment.

c. *Removal of Switch Shaft.*

- (1) Remove switch shaft cover (fig. 2-1)

from switch shaft access hole on front panel of receiver.

- (2) Remove three screws and three lockwashers which secure RF shield to left side of receiver, and remove RF shield.
- (3) Loosen two setscrews on switch shaft coupler (fig. 3-1) which connects switch shaft to gear train subassembly.
- (4) Slide switch shaft out through access hole in front panel of receiver ((1) above).

d. Removal of Push-Pull RF Amplifier Subassembly.

- (1) Remove switch shaft (c above).
- (2) Remove one screw and lockwasher (B, fig. 3-1) "and three screws (B, fig. 3-2).
- (3) Pull out subassembly.

e. Removal of Second RF Amplifier and balanced Modulator Subassembly.

- (1) Remove switch shaft (c above).
- (2) Remove one screw and lockwasher (C, fig. 3-1) and three screws (C, fig. 3-2).
- (3) Pull out subassembly.

f. Removal of First RF Amplifier Subassembly.

- (1) Remove switch shaft (c above).
- (2) Remove one screw and lockwasher (D, fig. 3-1) and three screws (D, fig. 3-2).
- (3) Pull out subassembly.

g. Removal of Mixer Subassembly.

- (1) Remove switch shaft (c above).
- (2) Remove one screw and lockwasher (E, fig. 3-1) and five screws (E, fig. 3-2).
- (3) Pull out subassembly.

h. Removal of Local Oscillator Subassembly.

- (1) Remove switch shaft (c above).
- (2) Remove one screw and lockwasher (F, fig. 3-1) and three screws (F, fig. 3-2).
- (3) Pull out subassembly.

i. Removal of IF Amplifier Subassembly.

- (1) **Remove seven screws (G, fig. 3-1).**
- (2) Pull out subassembly.

j. Removal of Audio Frequency Amplifier Subassembly.

- (1) Remove five screws (H, fig. 3-2).
- (2) Pull out subassembly.

k. Removal of Bfo Subassembly.

- (1) Loosen two screws (J, fig. 3-2).
- (2) Pull out subassembly.

l. Removal of Tuning Capacitor Subassembly.

- (1) Remove two screws (101, fig. 5-16) and two lockwashers (100) which secure cover (102) of gear train subassembly, and remove cover.
- (2) Remove capscrew and lockwasher (K, fig. 3-1) which secures tuning capacitor subassembly to gear train subassembly.
- (3) Loosen two setscrews on tuning capacitor shaft collar (fig. 3-1) which is part of gear train subassembly.
- (4) Loosen lowest screw of four screws (A, fig. 3-2) approximately three turns.
- (5) Remove screw and lockwasher (L, fig. 3-2).
- (6) Slide tuning capacitor subassembly towards front of receiver. Be careful that pair of tuning capacitor drive gears (fig. 3-1) in gear train subassembly do not bind on shaft of tuning capacitor subassembly. Pair of 84-tooth spur gears and tuning capacitor shaft collar may fall free.
- (7) Pull tuning capacitor subassembly out. It may be necessary to remove four screws (M, fig. 3-1) and press down on bottom of receiver chassis to allow removal of subassembly.

m. Removal of Gear Train Subassembly.

- (1) Remove power supply and servo compartment (b above).
- (2) Remove switch shaft (c above).
- (3) Perform procedures in l (1), (2), and (3) above.

- (4) Remove two screw's (N, fig. 3-1) on top of receiver chassis.
- (5) Remove two screws on bottom of receiver chassis which are directly opposite from two screw in (4) above.
- (6) Slide gear train subassembly toward rear of receiver until subassembly is free.

n. Disassembly of Gear Train Subassembly (fig. 5-16).

Note. Some of the items of the gear train subassembly are removed or loosened when the subassembly is removed from the receiver chassis (m above). These items are two setscrews (119), two setscrews (68), two screws (101), two lockwashers (100), and cover (102). Removal or loosening of these items are not repeated in the disassembly procedures below.

- (1) Remove two screws (116) anti two lockwashers (115) from front gear plate (103).
- (2) Remove screw (104) and lockwasher (105) at upper right corner of front gear plate.
- (3) Remove screw (111), lockwasher (112), flat washer (113), and dowel (114) at lower right corner of front gear plate.
- (1) Remove screw (122) and lockwasher (123) at upper left corner of front gear plate.
- (5) Remove screw (124), lockwasher (125), flat washer (126), and dowel (127) at lower left corner of front gear plate.
- (6) Remove two screws (120) and two lockwashers (121) that secure side plate (72) to front gear plate.
- (7) Remove screw (38) anti lockwasher (37). Spacer (81) will be free.
- (8) Loosen two setscrews (97) on collar (98).
- (9) Remove extension spring (117)
- (10) Loosen two setscrews (119) on switch shaft coupler (118), and remove switch shaft coupler.
- (11) Pull off front gear plate (103) and attached parts.
- (12) Remove three screws (109), three lockwashers (108), three flat washers (107), and three spacers (106).
- (13) Pull resolver B3 (110) free of front gear plate (103).
- (14) Remove tuning capacitor shaft collar (69), tuning capacitor drive gear (67), and two extension springs (66). Hubbed tuning capacitor drive gear (65) will be free.
- (15) Loosen two setscrews (60) on collar (61), and remove assembly of items (61 through 64).
- (16) Remove collar (61), spur gear (62), and load spring (63). Hubbed spur gear (64) will be free.
- (17) Remove spur gear assembly (70) from rear gear plate (58).
- (18) Remove spur gear assembly (71) from rear gear plate.
- (19) Remove spur gear assembly (73) from rear gear plate.
- (20) Remove spur gear assembly (74) from rear gear plate.
- (21) Remove spur gear assembly (77), and remove retaining ring (76).
- (22) Remove spur gear assembly (75) from rear gear plate.
- (23) Remove spur gear assembly (79) from rear gear plate.
- (21) Remove spur gear assembly (78) from rear gear plate.
- (25) Remove spur gear assembly (82) from rear gear plate.
- (26) Remove collar (98), spur gear (96), load spring (95), and hubbed spur gear (94). Electrical contact (93) will be free.
- (27) Loosen two setscrews (88) on collar (89), and remove assembly of items (89 through 92).
- (28) Remove collar (89), spur gear (90), and load spring (94). Hubbed spur gear (92) will be free.
- (29) Remove spur gear assembly (84) from rear gear plate.
- (30) Remove spur gear assembly (80) from rear gear plate.

- (31) Remove spur gear assembly (83) from rear gear plate.
- (32) Remove screw (1), lockwasher (2), flat washer (3), and dowel (4).
- (33) Remove screw (11), lockwasher (12), flat washer (13), and terminal post (14). Housing (59) will be free.
- (34) Remove two screws (15) and two lockwashers (16). Side plate (72) will be free.
- (35) Remove screw (40), lockwasher (41), flat washer (42), and dowel (43).
- (36) Remove screw (54), lockwasher (55), flat washer (56), and terminal post (57). Housing (99) will be free.
- (37) Remove three screws (5), three lockwashers (6), and three rim clamps (7).
- (38) Pull tuning synchro control transformer B1 (40) free of rear gear plate. Screws (8) and terminal lugs (9) may be removed if necessary.
- (39) Remove three screws (18), three lockwashers (19), and three rim clamps (20).
- (40) Pull synchro motor-generator set M61 (17) free of rear gear plate.
- (41) Remove two screws (33), two lockwashers (34), two flat washers (35), and two switch clamps (36).
- (42) Remove two screws (32) and two non-metallic washers (31). Switch wafer S1 M (23), four nonmetallic washers (24), and two spacers (29) will be free.
- (43) Remove two screws (21) and two non-metallic washers (22). Switch wafers S1 L (24) and S1 K (28), two spacers (25), two spacers (26), and switch plate (27) will be free.
- (44) Remove two screws (85), two lockwashers (86), and two flat washers (87).
- (45) Pull motor B2 (39) free of rear gear plate.
- (46) Remove two screws (44), two lockwashers (45), and two rim clamps (46).

- (47) Pull servo motor B5 (47) free of rear gear plate.
- (48) Remove three screws (51), three lockwashers (52), and three rim clamps (53).
- (49) Pull bearing synchro transmitter B1 (50) from rear gear plate. Screws (48) and terminal lugs (49) may be removed if necessary.
- (50) Remove ball bearings from the front gear plate and rear gear plate if desired. All ball bearings are identical except for the two ball bearings associated with spur gear assembly (83); these two ball bearings are identical to each other and are smaller than the others.

Caution: Do not remove the bronze bearing in the front gear plate and the bronze bearing in the gear plate. These bearings are associated with spur gear assembly (77). The bronze bearings are press-fitted; removing and replacing them may cause eccentricity of the gear plates and a poor fit of the bearings.

3-4. Reassembly and Lubrication of Receiver

a. General Reassembly Techniques.

- (1) *Meshing of gears.* Mesh gears as necessary when reassembling unless otherwise specified. Instructions to mesh gears are given only when special procedures are required.
- (2) *Locking screws.* Apply locking compound (blue varnish) to the threads of screws, including setscrews, not locked by lockwashers or locknuts. When the legend number or letter reference of an item is followed by the term "lock," apply blue varnish to the screw threads before tightening the screw.

b. Reassembly of Gear Train Subassembly (fig. 5-16).

- (1) Lubricate the two bronze bearings associated with spur gear assembly

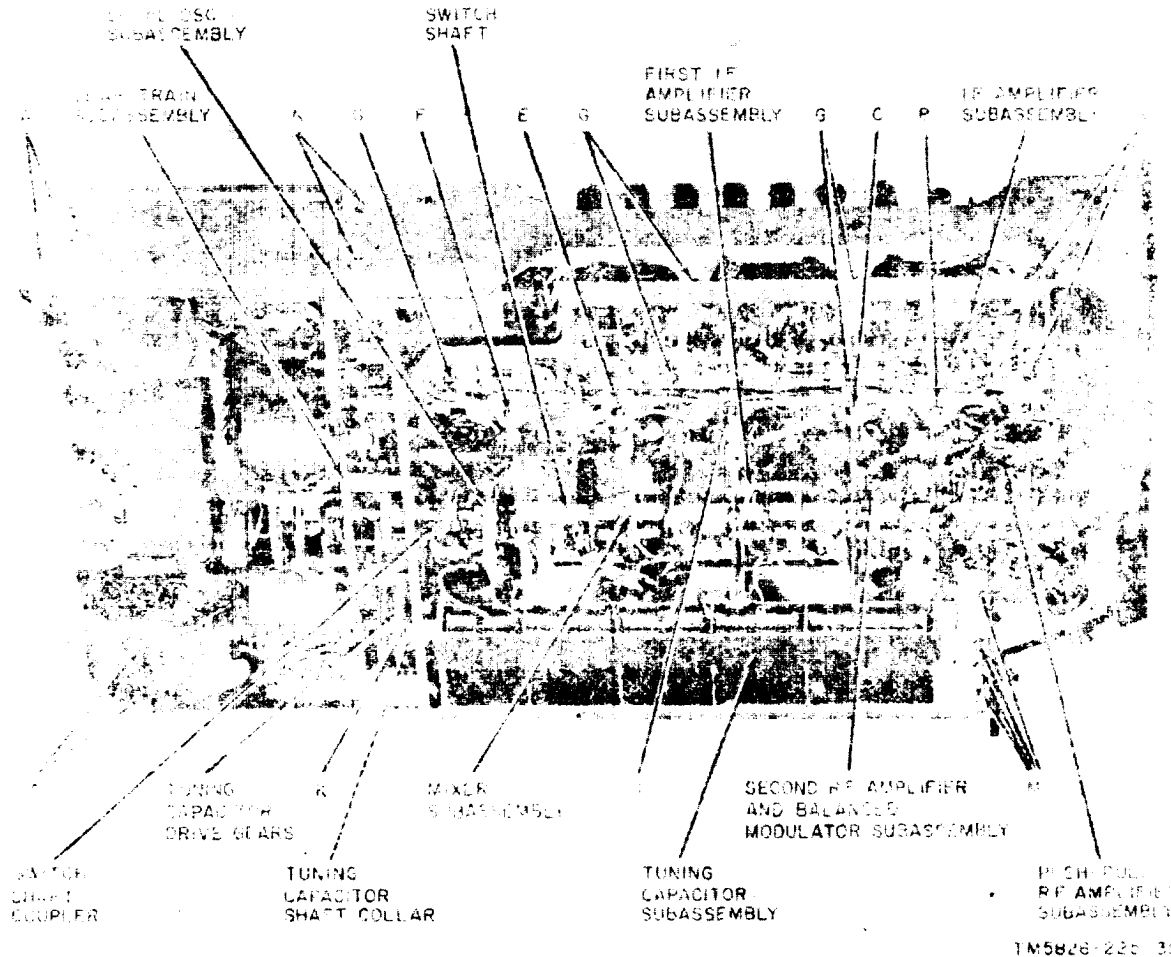

Figure 3-1. Receiver, left side view, dust cover removed.

(77) with one drop of oil (MIL-I-6085A); wipe off all excess with a clean, lint free cloth. Lubricate all ball bearings with oil (MIL-I-6085A). Remove the ball bearings from their gear plates, and use a mist spray or dip and centrifuge process to lubricate. Do not overlubricate the bearings; overlubrication can cause as much damage to a bearing as underlubrication. Use only the lubricant prescribed.

(2) Replace all ball bearings in their respective gear plates (58 and 103).

All ball bearings are identical except for the two ball bearings associated with spur gear assembly (83); these two ball bearings are identical to each other and are smaller than the others.

(3) Mount housing (59) to front gear plate (103) with screw (122), lock-washer (123), screw (124), lock-washer (125), flat washer (126), and dowel (127). Tighten screw (124) first.

(4) Mount side plate (72) to front gear

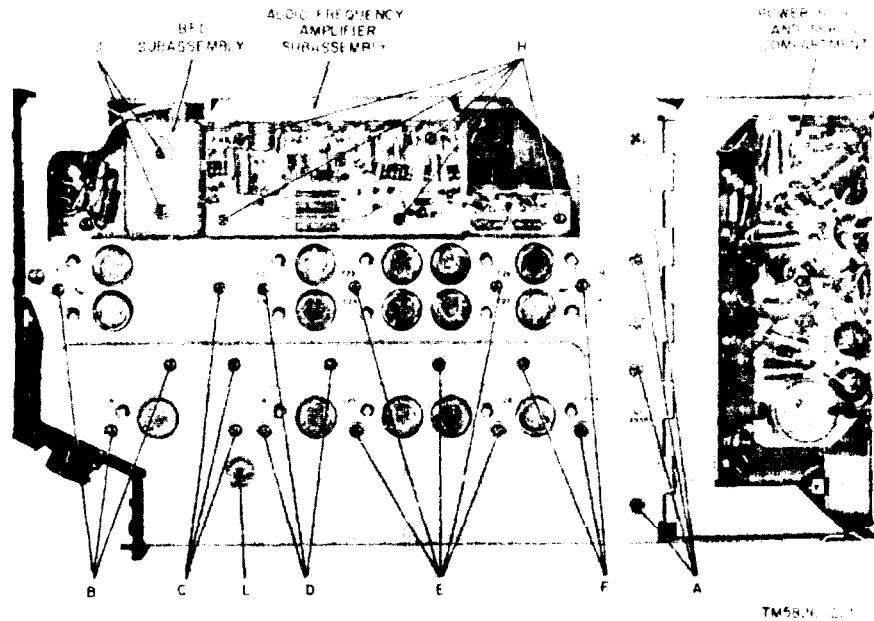

Figure 3-2. Receiver, right side view, dust cover removed.

- plate with two screws (120) and two lockwashers (121).
- (5) Mount housing (99) to front gear plate with screw (104), lockwasher (105), screw (111), lockwasher (112), flat washer (113), and dowel (114). Tighten screw (111) first.
- (6) Mount two screws (116) and two lockwashers (115) to front gear plate.
- (7) Mount resolver B3 (110) to front gear plate with three screws (109), three lockwashers (108), three flat washers (107), and three spacers (106).
- (8) Place spur gear assembly (84) in front gear plate.
- (9) Place spur gear assembly (80) in front gear plate.
- (10) Place spur gear assembly (82) in front gear plate.
- (11) Place spur gear assembly (83) in front gear plate.
- (12) Place retaining ring (76) on spur gear assembly (77), and place spur gear assembly (77) in front gear plate.
- (13) Place spur gear assembly (79) in front gear plate.
- (14) Place spur gear assembly (76) in front gear plate.
- (15) Place spur gear assembly (78) in front gear plate.
- (16) Place spur gear assembly (70) in front gear plate.
- (17) Place spur gear assembly (71) in front gear plate.
- (18) Place spur gear assembly (73) in front gear plate.
- (19) Place spur gear assembly (74) in front gear plate.
- (20) Place load spring (95) on hubbed spur gear (94). Insert one end of load spring into hole in hubbed spur gear (94).
- (21) Place spur gear (96) on assembly of (20) above. Position spur gear (96) so that other end of load spring (95) fits into hole in spur gear (96).
- (22) Place collar (98) on hub of hubbed spur gear (94). The chamfered end of

- collar should be against spur gear (96).
- (23) Hold hubbed spur gear (94), and rotate spur gear (96) six teeth clockwise (right-hand loading), as viewed from spur gear (96) end. Take up any slack before counting the six teeth.
 - (24) Keep right-hand loading as in (23) above, and place assembly of items (94 through 98) on shaft of resolver B3 (110). Mesh spur gears (94 and 96) with 17-tooth gear of spur gear assembly (84) which is nearest resolver B3.
 - (25) Tighten two setscrews (97, lock). Do *not* tighten setscrews on openings in split hub of hubbed spur gear (94). Tighten setscrews on solid portion of split hub.
 - (26) Mount motor 132 (39) to rear gear plate (58) with two screws (85), two lockwashers (86), and two flat washers (87).
 - (27) Attach screws (8) and terminal lugs (9) to tuning synchro control transformer B1 (10).
 - (28) Mount B1 (10) to rear gear plate (58) with three screws (5), three lockwashers (6), and three rim clamps (7).
 - (29) Mount servo motor-generator set MG1 (17) to rear gear plate with three screws (18), three lockwashers (19), and three rim clamps (20).
 - (30) Mount servo motor B5 (47) to rear gear plate with two screws (44), two loci-mashers (45), and two rim clamps (46).
 - (31) Attach screws (48) and terminal lugs (49) to bearing synchro transmitter B4 (50).
 - (32) Mount B4 (50) to rear gear plate with three screws (51), three lockwashers (52), and three rim clamps (53)
 - (33) Place load spring (63) on hubbed spur gear (64). Insert one end of load spring into hole in hubbed spur gear (64).
 - (34) Place spur gear (62) on assembly of (33) above. Position spur gear (62) so that other end of load spring (63) fits into hole in spur gear (62).
 - (35) Place collar (61) on hub of hubbed spur gear (64). The chamfered end of collar should be against spur gear (62).
 - (36) Place assembly (60 through 64) on shaft of tuning synchro control transformer B1.
 - (37) *Lightly* tighten two setscrews (60) just enough to hold assembly ((36) above) in place.
 - (38) Place load spring (91) on hub of hubbed spur gear (92). Insert one end of load spring into hole in hubbed spur gear (92).
 - (39) Place spur gear (90) on assembly of (38) above. Position spur gear (90) so that other end of load spring (91) fits into hole in spur gear (90).
 - (40) Place collar (89) on hub of hubbed spur gear (92). The chamfered end of collar should be against spur gear (90).
 - (41) Place assembly of items (88 through 92) on shaft of bearing synchro transmitter B4 (50).
 - (42) *Lightly* tighten two setscrews (88) just enough to hold assembly ((41) above) in place.
 - (43) Attach two extension springs (66) to hubbed tuning capacitor drive gear (65).
 - (44) Place tuning capacitor drive gear (67) on hub of hubbed tuning capacitor drive gear (65). Countersunk holes in gear (67) go toward hubbed gear (65). Attach other ends of extension springs (66) to gear (67).
 - (45) Place collar (69) on hub of hubbed gear (65), and *lightly* tighten two setscrews (68).
 - (46) Place assembly of items (65 through

- 69) in position near spur gear assembly (70).
- (47) Place rear gear plate (58) and attached items onto items assembled to front gear plate (103). All shafts must seat properly in bearings in rear gear plate. Mesh all gears. Spur gears (65 and 67) should mesh with one of 17-tooth gears on spur gear assembly (70).
 - (48) Place spacer (81) in position between two gear plates, and secure with screw (38) and lockwasher (37).
 - (49) Replace screw (1), lockwasher (2), flat washer (3), and dowel (4) on rear gear plate.
 - (50) Replace screw (11), lockwasher (12), flat washer (13), and terminal post (14) on rear gear plate.
 - (51) Replace two screws (15) and two lockwashers (16) on rear gear plate.
 - (52) Replace screw (40), lockwasher (41), flat washer (42), and dowel (43) on rear gear plate.
 - (53) Replace screw (54), lockwasher (55), flat washer (56), and terminal post (57) on rear gear plate.
 - (54) Insert electrical contact (93) against inside of housing (99), with the letter "X" marked on the switch wafer away from rear gear plate. Hooked end of electrical contact fits against bottom of housing, with hook facing away from housing. Curved center of electrical contact should make contact with shaft of B4 (50) and shaft of B3 (110).
 - (55) Place switch shaft coupler (118) on shaft of spur gear assembly (77), and tighten two setscrews (119, lock) nearest front gear plate (103). Do not tighten other two setscrews (119).
 - (56) Replace extension spring (117) on switch shaft coupler (118).
 - (57) Attach switch plate (27) to rear gear plate with two screws (33), two lockwashers (34), two flat washers (35), and two switch clamps (36).
 - (58) Place switch wafer S1-K (28) on shaft of spur gear assembly (77), with the letter "X" marked on the wafer away from gear plate. Note the position of the small notch in the shaft hole of the rotor of the switch wafer.
 - (59) Position the rotor of switch S1-L (24) so that the small notch in the shaft hole of the switch wafer is in the same position as the notch in switch wafer, S1-K (28).
 - (60) Place switch wafer S1-L (24) on shaft of spur gear assembly (77). Check that the notches in the shaft holes of switch wafers S1-L and S1-K are on the same flat of the shaft of spur gear assembly (77).
 - (61) Position switch wafers S1-L (24) and S1-K (28) so that the letter "X" marked on the switch wafers is nearest servo motor-generator set MG1 (17). Then secure switch wafers to rear gear plate with two screws (21), two nonmetallic washers (22), two spacers (25), and two spacers (26).
 - (62) Position rotor of switch wafer S1-M (23) so that the small notch in the shaft hole of the switch wafer is in the same position as the notches in switch wafers S1-L (24) and S1-K (28).
 - (63) Place switch wafer S1-M (23) on shaft of spur gear assembly (77), with the letter "X" marked on wafer away from rear gear plate. Check that notches in shaft holes of S1-M, S1-L, and S1-K are on same flat of shaft.
 - (64) Position switch wafer S1-M (23) so that the letter "X" on the wafer is nearest MG1 (17). Then secure S1-M to switch plate (27) with two screws (32), two nonmetallic washers (31), four nonmetallic washers (30), and two spacers (29).
 - (65) Loosen two setscrews (60) on collar (61).

- (66) Pull assembly of items (60 through 64) toward front gear plate (103) until spur gears (62 and 64) are unmeshed from 17-tooth gear on spur gear assembly (70).
- (67) Hold hubbed spur gear (64), and rotate spur gear (62) five teeth clockwise (right-hand loading), as viewed from spur gear (62) end. Take up any slack before counting the five teeth.
- (68) Keep right-hand loading as in (67) above, and push assembly (60 through 64) toward rear gear plate (58). Remesh gears (62 and 64) with 17-tooth gear on spur gear assembly (70).
- (69) Tighten two setscrews (60, lock). Do not tighten setscrews on openings in split hub of hubbed spur gear (64). Tighten setscrews on solid portion of split hub.
- (70) Apply a small amount of the following mixture to the teeth of all gears. Wipe off excess.
 - (a) 25 parts by weight of grease (MIL-G-3278A).
 - (b) 37 parts by weight of butyl alcohol.
 - (c) 37 parts by weight of xylene.

Note. Items 65 through 69 are adjusted after the tuning capacitor subassembly is replaced (d below). Items 88 through 92 are adjusted during adjustment and synchronization of the resolver servo system (para 3-18). Items 100, 101, and 102 are replaced after all subassemblies are replaced.

c. Replacement of Gear Train Assembly.

Note. Replace the gear train assembly before replacing the tuning capacitor subassembly (d below), switch shaft (m below), or power supply and servo compartment (n below).

- (1) Slide the gear train subassembly (fig. 3-1) into rear of receiver chassis.
- (2) Attach two screws (N, fig. 3-1, lock) on top of receiver chassis.
- (3) Attach two screws (lock) on bottom of receiver chassis which are directly opposite from two screws in (2) above.

d. Replacement of Tuning Capacitor Subassembly.

Note. Replace the gear train subassembly (c above) before replacing the tuning capacitor subassembly.

- (1) Replace tuning capacitor subassembly (fig. 3-1) in receiver chassis. Retighten four screws (M) if they were loosened during removal of tuning capacitor subassembly.
- (2) Loosen two setscrews on tuning capacitor shaft collar (fig. 3-1) in gear train subassembly. This collar is shown as item 69 in figure 5-16.
- (3) Loosen lowest of four screws (A, fig. 3-2) approximately three turns if power supply and servo compartment has been replaced.
- (4) Slide tuning capacitor subassembly toward gear train assembly. While doing so, hold assembly of tuning capacitor shaft collar and tuning capacitor drive gears (fig. 3-1) so that shaft of tuning capacitor subassembly fits into hub of one of the tuning capacitor drive gears.
- (5) Replace capscrew and lockwasher (K) that secures tuning capacitor subassembly to gear train subassembly.
- (6) Replace screw and lockwasher (L, fig. 3-2).
- (7) Retighten lowest of four screws ((3) above) .
- (8) Move tuning capacitor drive gears and tuning capacitor shaft collar (fig. 3-1) toward rear of receiver (toward rear gear plate (58, fig. 5-16) of gear train subassembly until drive gears are unmeshed from spur gear assembly (70) in gear train subassembly.
- (9) With drive gears unmeshed, hold hubbed tuning capacitor drive gear (65) and rotate tuning capacitor drive gear (67) four teeth clockwise (right-hand loading), as viewed from gear (67) end.
- (10) Keep loading in (9) above, and remesh tuning capacitor drive gears (65 and 67) with spur gear assembly (70) .

- (11) Check that shaft of tuning capacitor subassembly fits into hub of tuning capacitor drive gear (65). Then tighten two setscrews 68, lock). Final adjustment of the tuning capacitor subassembly is performed in paragraph 3-12.
- e. Replacement of Bfo Subassembly.
 - (1) Position subassembly (fig. 3-2) on receiver chassis.
 - (2) Replace five screws (J).
 - f. Replacement of Audio Frequency Amplifier Subassembly.
 - (1) Position subassembly (fig. 3-2) on receiver chassis.
 - (2) Replace five screws (H, lock).
 - g. Replacement of IF Amplifier Subassembly.
 - (1) Position subassembly (fig. 3-1) on receiver chassis.
 - (2) Replace seven screws (G, lock).
 - h. Replacement of Local Oscillator Assembly
 - (1) Position subassembly (fig. 3-1) on receiver chassis.
 - (2) Replace one screw and lockwasher (E, fig. 3-1) and five screws (E, fig. 3-2, lock). Do not tighten screws fully until switch shaft (*m* below) has been replaced.
 - i. Replacement of Mixer Subassembly.
 - (1) Position subassembly (fig. 3-1) on receiver chassis.
 - (2) Replace one screw and lockwasher (E, fig. 3-1) and five screws (E, fig. 3-2, lock). Do not tighten screws fully until switch shaft (*m* below) has been replaced.
 - j. Replacement of First RF Amplifier Subassembly.
 - (1) Position subassembly (fig. 3-1) on receiver chassis.
 - (2) Replace one screw and lockwasher (D, fig. 3-1) and three screws (D, fig. 3-2). Do not tighten screws fully until switch shaft (*m* below) has been replaced.
 - k. Replacement of Second RF Amplifier and Balanced Modulator Subassembly.
 - (1) Position subassembly (fig. 3-1) on receiver chassis.
 - (2) Replace one screw and lockwasher (C, fig. 3-1) and three screws (C, fig. 3-2, lock). Do not tighten screws fully until switch shaft (*m* below) has been replaced.
 - l. Replacement of Push-Pull RF Amplifier Subassembly.
 - (1) Position subassembly (fig. 3-1) on receiver chassis.
 - (2) Replace one screw and lockwasher (B, fig. 3-1) and three screws (B, fig. 3-2). Do not tighten screws fully until switch shaft (*m* below) has been replaced.
 - m. Replacement of Switch Shaft.
 - (1) Replace the gear train subassembly (*c* above), local oscillator subassembly (*h* above), mixer subassembly (*i* above), first RF amplifier subassembly (*j* above), second RF amplifier and balanced modulator subassembly (*k* above), and push-pull RF amplifier subassembly (*l* above) before replacing the switch shaft.
 - (2) Insert switch shaft (fig. 3-1) through switch shaft access hole (fig. 2-1) on front panel of receiver.
 - (3) Insert switch shaft into first switch wafer (S1-R) on push-pull RF amplifier subassembly (fig. 3-1). Note the position of the small notch in the shaft hole of switch wafer S1-R. The notches in the shaft holes of all switch wafers must lie on the same flat of the switch shaft.
 - (4) Insert switch shaft through shaft holes of switch wafers on subassemblies in (1) above, except for gear train subassembly. Rotate switch shaft as necessary while inserting so that notches in shaft holes of switch wafers lie on same flat of switch shaft. Do not insert switch shaft into switch shaft coupler (fig. 3-1) on gear train subassembly.

- (5) Tighten all screws on subassemblies in (1) above, except for gear train subassembly. Tighten screws which are in depressed area on left side of receiver (fig. 3-2) first, and then tighten remaining screw.
- (6) Secure RF shield to left side of receiver with three screws and three lockwashers.
- (7) Rotate switch shaft manually. Switch shaft should rotate smoothly and easily, and switch wafers should not bind. If necessary, loosen screws which secure subassemblies, reposition subassemblies slightly, and retighten screws.
- (8) Remove RF shield ((6) above).
- (9) Insert end of switch shaft into switch shaft coupler (fig. 3-1) on gear train subassembly.
- (10) Rotate switch shaft so that flats of switch shaft are aligned with flats of shaft of spur gear assembly (77, fig. 5-16). Align flats of shafts so that notches in switch wafers of subassemblies in (1) above are also aligned. This includes wafer switches S1-K, S1-L, and S1-M (28, 24, 23) in gear train subassembly. The tighten two setscrews (119, lock) on switch shaft coupler (118) which secure switch shaft. One of setscrew-s (119) should seat on one of flats of switch shaft.
- (11) Rotate switch shaft so that switch wafers are positioned as shown in schematic diagram of receiver (fig. 5-10).
- (12) Lubricate rotors of all switch wafers with the following mixture. Apply lubricant with a small camel's-hair brush, and remove all excess with a clean, lint free cloth.
 - (a) 25 parts by weight of grease, Rylson No. 2 E.P.
 - (b) 75 parts by weight of Stanisol solvent.
- (13) Replace RF shield ((6) above).
- (14) Replace switch shaft cover (fig. 2-1) on front panel of receiver,

n. Replacement of Power Supply and Servo Compartment.

- (1) Replace gear train subassembly (c above) before replacing power supply and servo compartment (fig. 3-2).
- (2) Replace four screws (A, fig. 3-1, lock).

o. Replacement of Dust Cover.

- (1) Slide dust cover over receiver chassis,
- (2) Tighten two screws (fig. 2-1) at front of receiver and one screw at rear.

3-5. Disassembly of Control Unit

Note. Refer to figure 5-17 throughout the disassembly of the control unit.

a. Removal of Front Panel.

- (1) Loosen four setscrews (96 and 101), and remove TUNE knob (97) and GAIN knob (102) from their shafts.
- (2) Loosen four setscrews (98, 100, and 104) and remove knobs (94, 99, and 105).
- (3) Remove two screws (108).
- (4) Remove two screws (106) and two rubber washers (107).
- (5) Remove front panel (93) from the control unit.
- (6) Loosen two Dzus fasteners (1) located on rear cover (2), and slide rear cover (2) off the control unit,
- (7) Slide the panel light assembly (92) away from front subpanel assembly (88) far enough to permit unsoldering of the two panel lamp leads. Unsolder and tag these leads,
- (8) Remove the panel light assembly (92) from the control unit.
- (9) Remove four screws (112), and four lockwashers (112).
- (10) Remove nut (114) and lockwasher (115) securing toggle switch (133) to front subpanel assembly (88).
- (11) Slide the front subpanel assembly (88) away from frame (136) far enough to permit unsoldering the leads from ammeter (90). Unsolder and tag these leads.
- (12) Remove front subpanel assembly (88) from the control unit.

- (13) Remove two screws (91) and remove ammeter (90) from front subpanel assembly (88).
- b. Removal of Attenuator. (R301).*
- (1) Loosen two Dzus fasteners (1) located on rear cover (2), and slide the rear cover (2) off the control unit.
 - (2) Loosen two setscrews (161), and remove crown gear (162) from the shaft on the variable attenuator (166).
 - (3) Remove nut (163) and lockwasher (164), and remove variable attenuator (166).
- c. Removal of Function Switch (S302).*
- (1) Remove the front panel as described in a above.
 - (2) Remove the attenuator, R301 (b above).
 - (3) Remove retaining ring (141) from the shaft of spur gear assembly (146).
 - (4) Remove spur gear assembly (146) from frame (136).
 - (5) Remove spring (126) from the grooved pin on frame (136).
 - (6) Remove detent follower (125) from the detent holder on frame (136).
 - (7) Remove switch detent (124) from the front of frame (136).
 - (8) Remove two screws (142), two lockwashers (143), two nonmetallic washers (144), switch section (140), two spacers (137), switch section (139); and two more spacers (138).
- d. Removal of LOOP switch (S303).*
- (1) Remove the front panel (a above).
 - (2) Remove the attenuator (R301) (b above),
 - (3) Remove nut (130) and lockwasher (129) from rotary switch (151).
 - (4) Remove rotary switch (151) from frame (136).
 - (5) Remove two nuts (160), two lockwashers (159), two flat washers (158), and terminal board (157) from rotary switch (151).
- e. Removal of Tuning Gear Train.*
- (1) Remove the front panel (a above).
- (2) Remove three screws (5) and three lockwashers (6) securing retaining plate (8) to frame (136).
 - (3) Remove fixed resistor (12) from retaining plate (8) by removing screw (7).
 - (4) Remove four screws (20) and nuts (17) securing connector (21) to retaining plate (8).
 - (5) Remove the retaining plate (8).
 - (6) Loosen setscrews (71) and (75) on collars (72) and (76), respectively.
 - (7) Pull out stop hub assembly (57), along with five stop washers (59, 61, 63, 65, and 67) and five flat washers (58,60, 62, 64, and 66), from the rear of frame (136).
 - (8) Remove two collars (72 and 76), flat washer (70), and worm gear (73).
 - (9) Loosen two setscrews (44) in collar (45) and remove spur gear (43) from shaft of helical gear assembly (52).
 - (10) Loosen two setscrews (53) in collar (54) and remove spur gear (120) from shaft of helical gear assembly (52).
 - (11) Remove washers (117, 118, and 119). The number of washers (117) may be more or less than shown. Record the number for reassembly.
 - (12) Remove helical gear assembly (52) from frame (136).
- f. Removal of Tuning Synchro (B301).*
- (1) Loosen two Dzus fasteners (1) located on rear cover (2), and slide the rear cover (2) off the control unit.
 - (2) Remove three screws (5) and three lockwashers (6) securing retaining plate (8) to frame (136).
 - (3) Remove fixed resistor (12) from retaining plate (8) by removing screw (7).
 - (4) Remove four screws (20) and nuts (17) securing connector (21) to the retaining plate (8),
 - (5) Remove the retaining plate (8).
 - (6) Loosen two setscrews (1) on collar

(45), and remove spur gear (43) from shaft of helical gear (52).

Note. If setscrews (44) cannot be reached, the tuning gear train must be disassembled (e above).

- (7) Loosen two setscrews (127) on collar (128), and remove spur gears (121, 123) from the shaft of transmitter synchro (156).
 - (8) Remove collar (128).
 - (9) Loosen the three screws (155) located around transmitter synchro (156) at the shaft end.
 - (10) Orient three rim-clinching clamps (153) to permit removal of transmitter synchro (156) and remove the transmitter synchro (156).
- g. Removal of Dial Drum.*
- (1) Set the range switch to 190-400.
 - (2) Remove the front panel (a above).
 - (3) Remove two screws (132), two lockwashers (131), two flat washers (134), and remove dial mask (135) from frame (136).
 - (4) Loosen two setscrews (35) on collar (37).
 - (5) Remove spur gear assembly (30), load spring (31), spur gear (32), and retaining ring (33) from the top of frame (136).
 - (6) Remove dial drum (41) from frame (136) using care not to distort spring (40).
- h. Removal of Range Switch (S304).*
- (1) Remove the front panel (a above).
 - (2) Remove two screws (87), two non-metallic screws (86), two lockwashers (85), and remove switch section (84).
 - (3) Remove two spacers (83).
 - (4) If it is desired to remove switch detent (82) and detent followers (56), perform the following procedure:
 - (a) Remove three screws (5) and three lockwashers (6) securing retaining plate (8) to frame (136).
 - (b) Remove fixed resistor (12) from retaining plate (8) by removing screw (7).
 - (c) Remove four screws (20) and four nuts (17) securing connector (21) to retaining plate (8).
 - (d) Remove retaining plate (8).
 - (f) Loosen setscrews (71) and (75) on collars (72) and (76), respectively.
 - (f) Pull out stop hub assembly (57), along with five stop washers (59, 61, 63, 65, and 67) and five flat washers (58, 60, 62, 64, and 66), from the rear of frame (136).
 - (g) Remove two collars (72 and 76), flat washer (70), and worm gear (73).
 - (h) Loosen the two setscrews (78) in collar (77), and remove the collar (77).
 - (i) Remove dial drum lever (81) from the frame (136).
 - (j) Remove spring (55) from the grooved pin in the frame (136).
 - (k) Remove detent follower (56) from the frame (136).
 - (l) Withdraw switch detent (82) from the rear of the frame (136).
- i. Removal of Lanpholder for Dial Lamps (DS307, DS308) .*
- (1) Set the range switch to 190-400.
 - (2) Loosen two Dzus fasteners (1) located on the rear cover (2), and slide the rear cover (2) off the control unit.
 - (3) Remove wire clamp (147), terminal lug (148), and lockwasher (149) by removing screw (152).

Note. Terminal stud (150) may be used in place of screw (152) on some control units.
 - (4) Remove two screws (34), and remove lamp bracket (29) from the frame (136).
 - (5) Two lamps (27) are removed from lamp bracket (29) by rotating electrical clamp (26) around the tubular rivet (25).

3-6. Reassembly and Lubrication of Control Unit

a. General. Lubrication of the control unit is included in the following reassembly pro-

cedures. After lubricating a lubricating a component, wipe off any excess lubricant with a clean, lint-free cloth. Refer to figure 5-17 throughout the re-assembly of the control unit.

b. Replacement of Range Switch (S304).

Note. If the switch detent (82) and detent follower (56) are to be replaced along with switch section (84), start this procedure with (1) below. But if just switch section (84) is to be replaced start this procedure with (14) below.

- (1) Apply a small quantity of NHL-L-7870 oil to the inner surface of the bearing located in the lower right-hand corner of frame (136), as viewed from the front.
- (2) Insert switch detent (82) through its bearing from the rear of frame (136).
- (3) Place notched end of detent follower (56) on the grooved pin on frame (136) with notch opening toward the edge of frame (136).
- (4) With the wheel of detent follower (56) in a detent of switch detent (82), connect spring (55) between riveted end of detent follower (56) and a grooved pin on frame (136).
- (5) Mount dial drum level (81) on a pin on the rear of frame (136), oriented so pin (80) protrudes toward the rear of frame (136). The shaft on switch detent (82) should protrude through the closed slot on dial drum lever (81).
- (6) Insert split sleeve bearing (79) into collar (77), and place them on the shaft of switch detent (82). Do not tighten setscrews (78) on collar (77).
- (7) Starting with flat washer (58), alternately place five flat washers (58, 60, 62, 64, and 66) with five stop washers (59, 61, 63, 65, and 67) on the shaft of stop hub assembly (57).
- (8) Place spring tension washer (68) and flat washer (69) on the shaft of stop hub assembly (37).
- (9) Apply a small quantity of MIL-L-7870 lubricant to each of the five flat washers (58, 60, 62, 64, and 66).
- (10) Insert the shaft of stop hub assembly (57) approximately ½ inch through the bearing located in the lower left corner of frame (136) as viewed from the rear.
- (11) Place flat washer (70), collar (72), worm gear (73) with shank toward the rear of frame (136), bearing sleeve (74), and collar (76) on the shaft of stop hub assembly (57) that is protruding through the bearing on frame (136).
- (12) Continue to insert the shaft of stop hub assembly (57) through the bearing on frame (136) and through the shaft of switch detent (82) until stop hub assembly is fully seated against the bearing on frame (136).
- (13) Hold collar (72) and worm gear (73) against the bearing through which the shaft of stop hub assembly (57) is inserted and, with stop hub assembly (57) seated against the bearing, tighten setscrews (71).
- (14) Slide collar (76) and bearing sleeve (74) toward the front of frame (136) until they are against the shaft of switch detent (82). Tighten two setscrews (75).
- (15) Orient switch section (81) so the x mark near one of the securing holes is facing toward the front of frame (136), and is to the right as seen from the front.
- (16) Slide switch section (84) onto the shaft of switch detent (82). The notch in the shaft slot of switch section (84) should be to the left as viewed from the front.
- (17) Mount switch section (84) to the front of frame (126) with two spacers (83), two screws (87), two nonmetallic washers (86), and two lockwashers (85).

Note. If contacts of switch section (84) are not wired, connection should now be made after wires are passed through hole in frame (136) adjacent to switch section (84).

- (18) If there are no other parts to be re-

placed, perform alignment procedures in paragraph 3-22.

c. *Replacement of Gear Train.*

- (1) If the range switch has been removed, replaced it (b above).
- (2) Apply a small quantity of MIL-L-7870 oil to the inner surface of the bearings located at the top and bottom of frame (136), and to the right as viewed from the front.
- (3) Place thrust washer (51), torsion spring (50), helical gear (49), helical spring (48), and flat washer (47) around gear shank of helical gear assembly (52).
- (4) Place the ends of torsion spring (50) into the retaining holes in helical gear (49) and helical gear assembly (52).
- (5) Squeeze flat washer (47) together with helical gear assembly (52), and push retaining ring (46) into the groove around gear shank of helical gear assembly (52).
- (6) Slide collar (44) onto the longer section of shaft on helical gear assembly (52).
- (7) Slide collar (54) on the shorter section of shaft on helical gear assembly (52).
- (8) Orient helical gear assembly (52) so the shorter section of shaft is pointed down.
- (9) Place helical gear assembly (52), along with collars (44 and 45), between the two bearings located at the top and bottom of frame (136), and to the right as viewed from the front.
- (10) Place flat washers (117), spring tension washer (118) and another flat washer (119) around the shank of spur gear (120).
Note. The number of flat washers (117) was recorded in the disassembly procedure of the gear train in paragraph 3-5e.
- (11) Insert the shank of spur gear (120) through the bottom bearing on frame (136), and slide the shank of spur gear, (120) over the shorter shaft of helical gear assembly (52).
- (12) With the shaft of helical gear assembly (52) flush with bottom of recess in spur gear (120), slide collar (54) over the end of the shank of spur gear (120) and tighten two setscrews (53).
- (13) Push helical gear assembly (52) downward until helical gear (49) is the only gear engaged with worm gear (73).
- (14) Rotate spur gear (120) eight teeth clockwise as viewed from the bottom of frame (136).
- (15) Push helical gear assembly (52) upward until helical gear (49) and the gear on helical gear assembly (52) are both engaged with worm gear (73).
Note. In the following procedures, do not allow helical gear (49) or the gear on helical gear assembly (52) to become disengaged with worm gear (73). Disengagement will cause loss of spring loading between helical gear (49) and helical gear assembly (52). If disengagement occurs, repeat (13), (14) and (16) above to restore spring loading.
- (16) Insert shank of spur gear (43) through the top bearing on frame (136), and slide the shank of spur gear (43) over the longer shaft of helical gear assembly (52).
- (17) With the shaft of helical gear assembly (52) flush with the bottom of the recess in spur gear (43), slide collar (45) over the shank of spur gear (43) and tighten two setscrews (44).
- (18) Loosen two setscrews (53) and slide collar (54) down until it is against the bearing in the bottom of frame (136).
- (19) Apply blue varnish to the threads of two setscrews (53), and tighten two setscrews (53).
- (20) Loosen two setscrews (44) and slide collar (45) up until it is against the bearing at the top of frame (136).
- (21) Apply blue varnish to the threads of two setscrews (44), and tighten.
- (22) If there are no other parts to be replaced, perform alignment procedures in paragraph 3-22.

d. Replacement of Dial Drum.

- (1) If the gear train is removed, replace it (c above).
- (2) Apply a small quantity of MIL-L-7870 oil to the inner surface of the bearings located at the top and bottom, and in the center, of frame (136).
- (3) Place load spring (31) around the shank of the gear on spur gear assembly (30).
- (4) Slide spur gear (32) onto the shank of the gear on spur gear assembly (30).
- (5) Place the ends of load spring (31) in the retaining holes in spur gear (32) and the gear on spur gear assembly (30).
- (6) Place retaining ring (33) in the slot around the shaft of spur gear assembly (30).
- (7) Loosen two setscrews (78) on collar (77) to allow the lever of dial drum lever (81) to be pushed to the bottom of frame (136).
- (8) Insert the shaft of spur gear assembly (30) through the top of the bearing located at the top and center of frame (136).
- (9) Place bearing sleeve (38) inside collar (37) and slide them over the shaft of spur gear assembly (30).
- (10) Place helical spring (40) around the shaft of spur gear assembly (30).
- (11) Insert the shaft of spur gear assembly (30) into dial drum (41), and set dial drum (41) on top of the lever of dial drum lever (81).
- (12) Rotate collar (77) until dial drum lever (81) raises dial drum (41) approximately $\frac{1}{4}$ inch from the top of frame (136).
- (13) Tighten one of the setscrews (78) on collar (77).
- (14) Place washer (42) on the end of the shaft on spur gear assembly (30), and insert the end of the shaft into

the bearing located at the bottom and center of frame (36).

- (15) Lower spur gear assembly (30) until just one spur gear (32) is engaged with spur gear (43).
- (16) As viewed from the top, rotate dial drum (41) clockwise until the gear on spur gear assembly (30) rotates clockwise 11 teeth.
- (17) Lower spur gear assembly (30) until the gear on spur gear assembly (30) engages with spur gear (43).
- (18) Loosen setscrew (78) on collar (77) and let dial drum lever (81) lower dial drum (41) to the bottom of frame (136).
- (19) Place the bottom of helical spring (40) over the center post in the bottom of dial drum (42).
- (20) Insert the hooked end of helical spring (40) into the hole in collar (37).
- (21) As viewed from the top, rotate collar (37) clockwise until one revolution of tension is placed on helical spring (40).
- (22) Apply blue varnish to the threads of two setscrews (35).
- (23) Tighten two setscrews (35).
- (24) If there are no other parts to be replaced, perform alignment procedures in paragraph 3-22.

e. Replacement of Tuning Synchro (B301).

- (1) If the dial drum is removed, replace it (d above).
- (2) Use three screws (155) and three lockwashers (154) to loosely secure three rim-clenching clamps (153) to frame (136).
- (3) Insert the shaft of transmitter synchro (156) through the mounting hole in frame (136), and secure transmitter synchro (156) to frame (136) with three rim-clenching clamps (153),
- (4) Place load spring (122) around the shank of spur gear (123).
- (5) Slide spur gear (121) over the shank of spur gear (123), and insert the

ends of load spring (122) into the retaining holes in spur gears (121 and 123).

- (6) Place collar (128) on the shank of spur gear (123), and tighten two setscrews (127) only as much as necessary to retain collar (128) on the shank of spur gear (123).
- (7) With collar (128) towards frame (136), slide the two spur gears (121 and 123) onto the shaft of transmitter synchro (156) only as far as necessary to engage spur gear (121) with spur gear (120).
- (8) As viewed from the bottom of frame (136), rotate spur gear (123) eleven teeth clockwise and engage spur gear (123) with spur gear (120).
- (9) Tighten two setscrews (127).
- (10) If there are not other parts to be replaced, perform alignment procedures in paragraph 3-22.

f. Replacement of Function Switch (S302).

- (1) Orient switch section (139) so the side with the X mark is facing the same direction as the front of frame (136), and the X mark is towards the top. The notch in the shaft slot of switch section (139) should be at the left as viewed from the front.
- (2) Orient switch section (140) the same as switch section (139) is oriented.
- (3) Use two spacers (137) to separate switch sections (139, 140) from each other, and two spacers (138) to separate switch sections (139 and 140) from frame (136).
- (4) Use two screws (142), two lockwashers (143), and two nonmetallic washers (144) to secure switch sections (139 and 140) and spacers (137 and 138) to frame (136).
- (5) Apply a small amount of MIL-L-7870 oil to the inner surface of the bearing located on the lower left edge of frame (136) as viewed from the front.
- (6) Insert the shaft of switch detent

(124) through the front of the bearing located on the lower left edge of frame (136) as viewed from the front.

- (7) Continue to insert the shaft of switch detent (124) through the shaft slots of switch sections (139 and 140). Seat switch detent (124) against the bearing on frame (136).
- (8) Place the notch of detent follower (125) on the lower left-hand grooved pin on frame (136) with notch opening facing left, as viewed from the front.
- (9) With the wheel of detent follower (125) in a detent of switch detent (124), connect spring (126) between rivet of detent follower (125) and the grooved pin on the front of frame (136).
- (10) Slide spring tension washer (145) over the shaft of spur gear assembly (146).
- (11) Insert the shaft of spur gear assembly (146) as far as possible through the bearing and the shaft of switch detent (124) from the rear of frame (136).
- (12) Place retaining ring (141) in the slot around the shaft of spur gear assembly (146).

g. Replacement of Attenuator (R301).

- (1) If the function switch is removed, replace it (f above).
- (2) If variable attenuator (166) is not connected to leads, make the connections now.
- (3) Place lockwasher (165) on mounting shank of variable attenuator (166), and insert the shank of variable attenuator (166) through the mounting hole in frame (136).
- (4) Secure variable attenuator (166) to frame (136) with lockwasher (164) and nut (163).
- (5) Place crown gear (162) on the shaft of variable attenuator (166) so crown gear (162) meshes with the spur gear on spur gear assembly (146).

(6) Apply blue varnish to the threads of two setscrews (161).

(7) Tighten two setscrews (161).

h. Replacement of LOOP Switch (S303).

(1) If rotary switch (151) is not wired, connect the leads now.

(2) Insert the shank of rotary switch (151) into the hole in the upper left corner of frame (136).

(3) Secure rotary switch (151) to frame (136) with lockwasher (129) and nut (130).

(4) Orient terminal board (157) so resistor R306 (4,700 ohms) is on top.

(5) Use two nuts (160), two lockwashers (159), and two flat washers (158) to secure terminal board (157) to rotary switch (151).

i. Replacement of Rear Retaining Plate.

(1) Slide spacer plate (19) around rear portion of connector (21). Align the mounting holes on spacer plate (19) with the mounting holes on connector (21).

(2) Fasten connector (21) and spacer plate (19) to retaining plate (8) with four screws (20) and four nuts (17).

(3) Secure fixed resistor (12) and solder lug (9) to retaining plate (8) with screw (7).

(4) Secure retaining plate (8) to frame (136) using three screws (5) and three lockwashers (6). Use care to avoid pinching or straining the leads.

j. Replacement of Front Panel.

(1) Secure dial mask (135) to the front of frame (136) with two screws (132), two lockwashers (131), and two flat washers (134).

(2) Fasten ammeter (90) to front subpanel assembly (88) using two nuts (89) and two screws (91).

(3) Place front subpanel assembly (88) over the shafts protruding from the front of frame (136), and insert toggle switch (143) through the hole in front subpanel assembly (88).

(4) Secure toggle switch (133) to front subpanel assembly (88) using lockwasher (115) and nut (114).

(5) If ammeter (90) is not wired, connect leads now.

(6) Pass the two panel lamp leads through the hole in the lower left corner of frame (136) and through the slot in front subpanel assembly (88).

(7) Fasten front subpanel assembly (88) to frame (136) using four screws (112) and four lockwashers (113).

(8) Solder the two panel lamp leads to the two terminals on panel light assembly (92).

(9) Fasten panel light assembly (92) to front panel (93) using two screws (108).

(10) Place front panel (93) over the shafts protruding from the front of frame (136), and secure front panel (93) to frame (136) using two screws (106) and two rubber washers (107).

(11) Place function knob (105) on its shaft, leaving a small gap between function knob (105) and front panel (93). Rotate function knob (105) fully counterclockwise. Function knob (105) should point to OFF.

(12) Tighten setscrew (104).

(13) Place range knob (94) on its shaft, leaving a small gap between range knob (94) and front panel (93). Rotate range knob (94) fully counterclockwise. Range knob (94) should point to 190-400.

(14) Tighten setscrew (98).

(15) Place flat washer (103) and GAIN knob (102) on shaft protruding from function knob (105). Leave a small gap between function knob (105) and GAIN knob (102) in addition to the gap caused by flat washer (103).

(16) Tighten two setscrews (101).

(17) Place flat washer (95) and TUNE knob (97) on shaft protruding from range knob (94). Leave a small gap between range knob (94) and TUNE

knob (97) in addition to the gap caused by flat washer (96).

- (18) Tighten two setscrews (96).
- (19) Place loop knob (99) on its shaft and align loop knob (99) so it is in a vertical position.
- (20) Tighten two setscrews (100).

k. Replacement of Rear Cover.

- (1) Perform alignment procedures contained in paragraph 3-22.

- (2) Carefully slide rear cover (2) over the rear of the control unit.
- (3) Secure rear cover (2) to the control unit by tightening two Dzus fasteners (1).

3-7. Periodic lubrication

No periodic lubrication is required between disassembly intervals.

Section II. ALIGNMENT

3-8. General

Alignment and adjustment procedures for Radio Receiver R-1391/ARN-83 are given in paragraphs 3-10 through 3-20. Voltage and frequency adjustment for Inverter, Power, Static CV-2128/ARN-83 is given in paragraphs 3-21 and 3-21.1. Alignment for Direction Finder Control C-6899/ARN-83 is given in paragraph 3-22. Antenna AS-1863/ARN-83 does not require alignment. The test equipment and additional equipment required for alignment and adjustment are listed in paragraph 3-9.

3-9. Test Equipment and Additional Equipment Required for Alignment

a. Test Equipment.

- (1) Test Set, Direction Finder Set AN/ARM-93.
- (2) Signal Generator AN/URM-25(), two each.
- (3) Output Meter TS-585/U.
- (4) Multimeter ME-26/U.
- (5) Tuning capacitor test cable (fig. 8-45) consisting of the following:
 - (a) Connector (Pi), Cannon DPXE. 45-34P-0201.
 - (b) Connector (P2), Cannon DPX 45 33S.
 - (c) Wire, #22 AWG, stranded, insulated (7 feet),
- (6) Frequency Meter AN/USM-26().
- (7) Oscilloscope AN/USM-140.

b. Additional Equipment.

- (1) Dc power supply, 27.5 volts.

- (2) Headset HS-33, or equivalent.
- (3) Stopwatch.
- (4) RF balance test jig (fig. 8-4), consisting of the following:
 - (a) Connector, Bendix PTOGA-10-6S (PI).
 - (b) Two connectors, UG-912A/U (P2 P3).
 - (c) Two resistors, 1/2 watt, 51 ohms, ± 1 percent, type RN65D51R1F (R1, R2).
 - (d) Two capacitors, 500 volts, 10 μf , ± 10 percent, type CM05C100K09 (C1, C2).
 - (e) Capacitor, 500 volts, 240 μf , ± 6 percent, type CM05F241J03. (C3).

3-10. Adjustment of Tuning Servo Tachometer Feedback

a. Remove the cover from the gear train assembly of the receiver.

b. Connect the equipment as shown in figure 2-2. It is not necessary to connect the signal generator, audio output meter, or headset.

c. set the switches on the test set as follows:

- (1) DC POWER switch to ON.
- (2) RECEIVER-CONTROL switch to RECEIVER,
- (3) GONIO DRIVE switch to ON.

d. Set the switches on the control unit as follows :

- (1) Function switch to ANT.

- (2) Range switch to 190-400.
 - (3) TUNE control for 300 kc on the FREQUENCY indicator.
 - (4) BFO-OFF switch to OFF.
- e. Loosen the locknut on resistor R111 (fig. 2-8) on the receiver, and rotate R111 fully clockwise.
- f. Rotate the TUNE control on the control unit while observing the operation of the gear train connected to the sections of capacitor c1 (fig. 2-8).
- g. Adjust R111 counterclockwise until the gear train overshoots the new proper position and reverses its direction to correct for the overshoot. Adjust R111 until this effect is small but still noticeable.
- h. Tighten the locknut on R111, and replace the cover on the gear train assembly.

3-11. Function and Range Switch Centering Adjustments

- a. Obtain access to the rear of the gear train assembly of the receiver as follows:
- (1) Remove the two outside, rearmost screws on the top of the chassis.
 - (2) Remove the two rearmost screws on the bottom of the chassis.
 - (3) Swing out the rear of the chassis to the right, as viewed from the front of the receiver.
- b. Connect the equipment as shown in figure 2-2. It is not necessary to connect the signal generator, audio output meter, or headset.
- c. Set the switches on the control unit as follows :
- (1) Function switch to ANT.
 - (2) Range switch to 400-350.

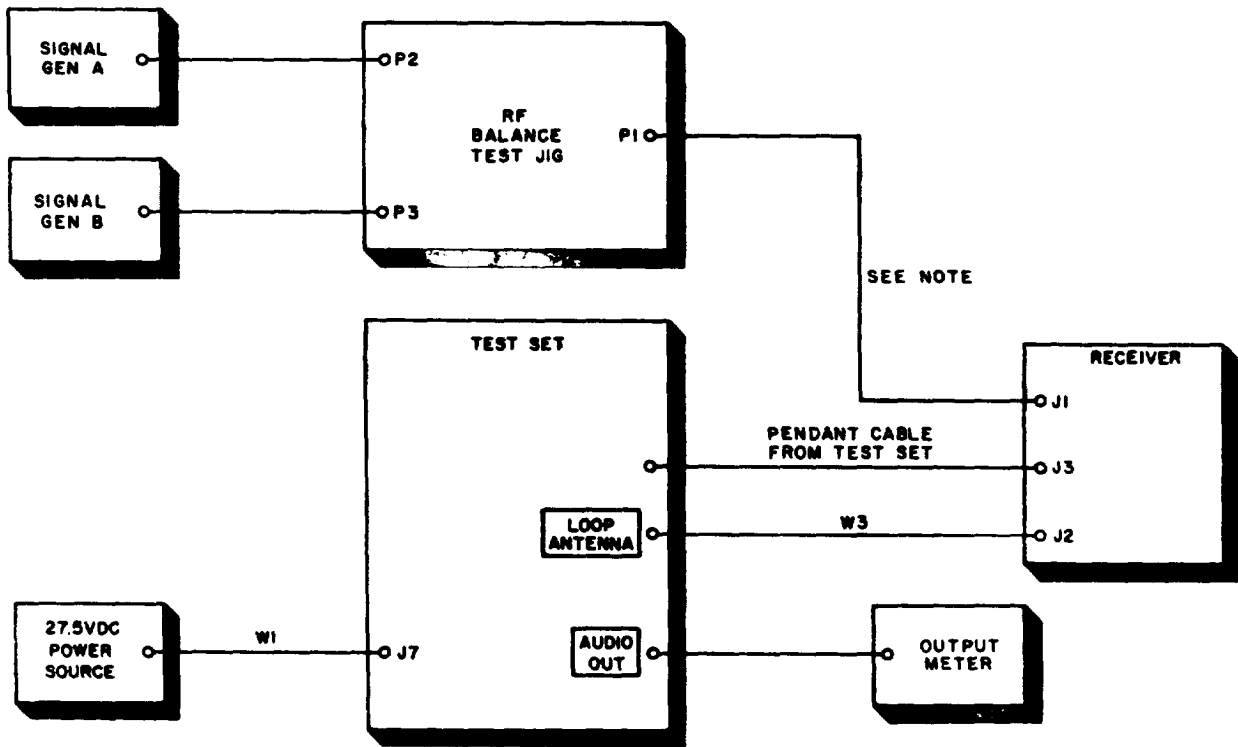

NOTE:
PI OF TEST JIG CONNECTS DIRECTLY TO J1 OF RECEIVER.

TM5826-225-35-60

Figure 3-3. RF balance adjustment test setup.

- (3) BFO-OFF switch to OFF.
- d. Set the switches on the test set as follows:
 - (1) DC POWER switch to ON,
 - (2) RECEIVER-CONTROL switch to RECEIVER.
 - (3) GONIO DRIVE switch to ON.
- e. Set the function switch on the control unit to LOOP. Then return the switch to ANT.

f. Note the position of the switch rotors which are connected mechanically to the gear train subassembly. All switch rotors should be

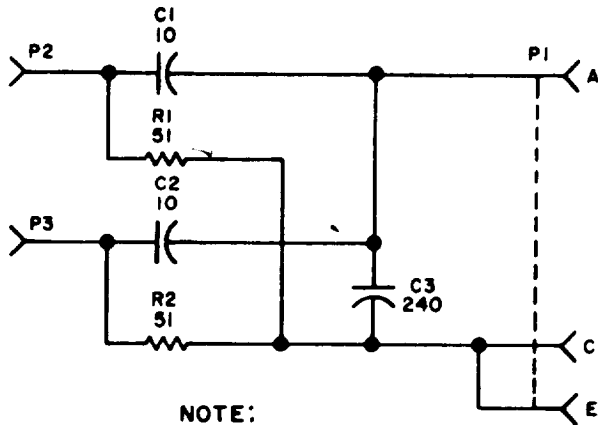

NOTE:
RESISTANCES ARE IN OHMS,
CAPACITANCES IN MICROMICROFARADS.

TM5826-225-35-75

Figure 3-4. RF balance test jig, schematic diagram.

positioned as shown on the schematic diagram of the receiver (fig. 5-10 or 5-10.1).

g. If the rotors are not positioned as in f above, loosen screws (33, fig. 5-16) and rotate switch wafer (23) until tabs are centered. Then retighten screws {33}.

3-12. Adjustment and Synchronization of Tuning Capacitor

a. Loosen setscrews (68, fig. 5-16) on collar (69) of gear train assembly in the receiver.

b. Swing out the rear of the chassis (para 3-11a).

c. Connect the input terminal of the vtm to S3 of B1 (fig. 2-7), Connect the ground terminal of the vtm to S1 of B1.

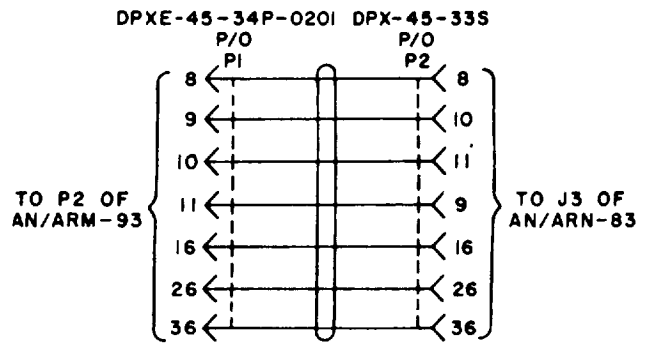

TM5826-225-35-78

Figure 3-5. Schematic diagram of tuning capacitor test cable.

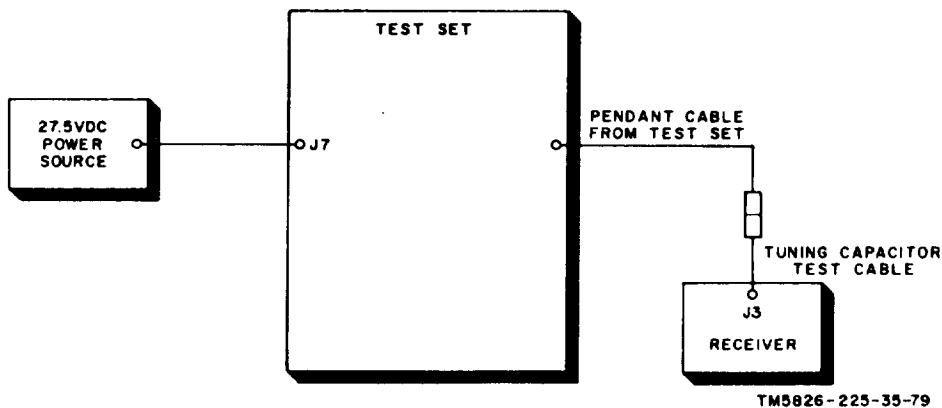

TM5826-225-35-79

Figure 3-6. Block diagram of adjustment and synchronization of tuning capacitor setup.

d. Connect the equipment as shown in figure 3-6. A schematic diagram of the tuning capacitor test cable is shown in figure 3-5.

e. Set the control unit range switch to 850-1750.

f. Adjust the control unit TUNE control so that the hairline of the FREQUENCY indicator bisects the small circle located between 1,400 and 1,500 kc.

g. Set the control unit switches as follows:

- (1) Function switch to ANT.
- (2) BFO-OFF switch to OFF.

k. Set the test set switches as follows:

- (1) RECEIVER-CONTROL switch to RECEIVER.
- (2) DC POWER switch to ON.

i. Rock the control unit TUNE control back and forth across the small circle on the FREQUENCY dial and adjust it for a null (minimum) indication on the vtvm.

j. Manually rotate the shaft which drives capacitor C1 (fig. 2-8) until the rotor plates of section C1-E (nearest the gear train) are fully meshed with the stator plates. The plates must be exactly meshed, with the tops of the rotor plates exactly in line with the tops of the stator plates.

k. Tighten the setscrews (68, fig. 5-16) on collar (69). Be careful that the split gears on the capacitor shaft do not become unmeshed and lose their spring loading.

CAUTION

After tightening the setscrews (k above), do not move the control TUNE control until the tuning capacitor test jig has been removed.

l. Throw the test set DC POWER switch to OFF.

m. Disconnect the vtvm.

n. Remove the tuning capacitor test jig from the equipment setup, and connect P2 of the test set directly to J3 of the receiver.

o. Throw the test set DC POWER switch to ON.

p. Slowly rotate the control unit TUNE control in a clockwise direction. The rotor plates of capacitor C1 should rotate out of mesh with the stator plates.

3-13. Local Oscillator Alignment

a. Connect the equipment as shown in figure 2-2. It is necessary to connect the audio output meter.

b. Loosen the locknuts on resistors R82, R90, and R131 (fig. 2-8) on the receiver, and adjust each resistor fully clockwise.

c. Adjust R136 fully clockwise (fig. 2-8), and then adjust R136 five turns counterclockwise.

d. Set the switches on the control unit as follows :

- (1) BFO-OFF switch to BFO.
- (2) Function switch to ANT.

e. Set the switches on the test set as follows:

- (1) DC POWER switch to ON.
- (2) RECEIVER-CONTROL switch to RECEIVER.
- (3) GONIO DRIVE switch to ON.

f. Set the 150 PF-270PF switch on the sense antenna adapter to 150 PF.

g. Set the range switch on the control unit to 190-400, and adjust the TUNE control on the control unit for 390 kc on the FREQUENCY indicator.

h. Set the frequency of the signal generator to 390 kc, plus or minus 0.1 kc.

i. Modulate the signal generator output 30 percent with 400 cps. Maintain this modulation throughout the procedures.

j. Adjust C36 (fig. 2-16 or 2-16.1) until a zero beat is heard in the headset.

k. Adjust the TUNE control on the control unit for 200 kc on the FREQUENCY indicator,

l. Set the signal generator to 200 kc, plus or minus 0.1 kc.

m. Listen for a zero beat in the headset while adjusting the TUNE control on the con-

trol unit to 1.5 kc on either side of 200 kc (198.5 kc to 201.5 kc). If a zero beat is not heard, remove the cover of L3 (fig. 2-16 or 2-16.1) and adjust L3 for a zero beat at 200 kc.

n. Repeat g through m above until a zero beat is heard at both 390 kc and 200 kc.

o. Temporarily replace the cover of L13 (do not solder) and repeat g through m above for the zero beats.

p. Set the range switch on the control unit to 400-850, and adjust the TUNE control on the control unit for 800 kc.

q. Set the signal generator to 800 kc, plus or minus 0.1 kc.

r. Adjust C40 (fig. 2-16 or 2-16.1) for a zero beat in the headset.

s. Adjust the TUNE control on the control unit for 420 kc.

t. Set the signal generator to 420 kc, plus or minus 0.1 kc.

u. Listen for a zero beat in the headset while adjusting the TUNE control on the control unit to 2.5 kc on either side of 420 kc (417.5 kc to 422.5 kc). If a zero beat is not heard remove the cover of L4 (fig. 2-16 or 2-16.1) and adjust L4 for a zero beat at 420 kc.

v. Repeat p through u above until a zero beat is heard at both 800 kc and 420 kc,

w. Temporarily replace the cover of L4 (do not solder). and repeat p through u above for the zero beats.

x. Set the range switch on the control unit to 850-1750, and adjust the TUNE control on the control unit for 1700 kc.

y. Set the signal generator to 1700 kc plus or minus 0.1 kc.

z. Adjust the TUNE control on the control unit for 900 kc.

aa. Adjust C44 (fig. 2-16 or 2-16.1) for a zero beat in the headset.

ab. Set the signal generator to 900 kc, plus or minus 0.1 kc.

ac. Listen for a zero beat in the headset while adjusting the TUNE control on the control unit to 5.0 kc either side of 900 kc (895 kc to 905 kc). If a zero beat is not heard, remove the cover of L5 (fig. 2-16 or 2-16.1) and adjust L5 for a zero beat at 900 kc.

ad. Repeat x through ac above until a zero beat is heard at both 1700 kc and 900 kc.

ae. Temporarily replace the cover of L5 (do not solder) and repeat x through ac above for the zero beats.

af. Solder the covers in place on L3, L4, and L5.

3-14. RF Alignment

a. Connect the equipment as shown in figure 2-2. -

b. Perform the procedures in paragraph 3-13b, c, d, and e.

c. Set the 150PF-270PF switch on the sense antenna adapter to 150PF.

d. Set the range switch on the control unit to 190-400, and adjust the TUNE control on the control unit for 390 kc on the FREQUENCY indicator.

e. Modulate the signal generator output 30 percent with 400 cps. Maintain this modulation unless instructed otherwise.

f. Set the frequency of the signal generator to 390 kc (the same as the receiver setting) as determined by a zero beat in the headset.

g. Set the BFO-OFF switch on the control unit to OFF.

h. Disconnect the headset from the test set.

i. Adjust the GAIN control on the control unit to approximately three-fourths of the fully clockwise position (maximum gain).

j. Adjust the output of the signal generator for 20 milliwatts (row) on the audio output meter.

NOTE

Maximum sharpness of tuning indi-

ation is achieved by maintaining approximately 20-mw output on the audio output meter.

k. Adjust C16 (fig. 2-12 or 2-12.1), C23, and C26 (fig. 2-13 or 2-13.1), in that order, for maximum indication on the audio output meter.

l. Check that the screwdriver slots in C16, C23, and C26 are not parallel to the front-to-rear axis of the receiver. If any of the screwdriver slots lie parallel to this plane, the corresponding transformer for that capacitor (T104 for C16, T107 for C23, and T10 for C26) must be adjusted. If T104 (fig. 2-12 or 2-12.1), T107, or T10 (fig. 2-13 or 2-13.1) must be adjusted, proceed as follows:

- (1) Reconnect the headset to the test set.
- (2) Set the BFO-OFF switch on the control unit to BFO.
- (3) Adjust the TUNE control on the control unit for 200 kc.
- (4) Set the signal generator to 200 kc as determined by a zero beat in the headset.
- (5) Set the BFO-OFF switch on the control unit to OFF.
- (6) Disconnect the headset.
- (7) Unsolder and remove the cover of the transformer to be adjusted (T104, T107, or T10).
- (8) Adjust the output of the signal generator for 2 mw on the audio' output meter.
- (9) Adjust the transformer T107 above for maximum output on the audio output meter.
- (10) Replace and resolder the cover of the transformer.
- (11) Repeak capacitors C16, C23, and C26 at 390 kc (d through k and (1) through (10) above).

m. Repeat the procedures in d through l above for the capacitors (figs. 2-12 or 2-12.1, and fig. 2-13 or 2-13.1) and frequency settings listed in the chart below. If necessary, adjust

the corresponding transformers (figs. 2-12 or 2-12.1 and 2-13 or 2-13.1). Always repeak the capacitors if the corresponding transformers require adjustment. Disconnect the headset from the test set when observing the audio output meter.

Capacitor	Capacitor adjustment frequency setting	Coil	Coil I tjlubrwlt frequency setting
C17	800	T105	420
C24	800	T108	420
C27	800	T11	420
C18	1700	T106	900
C25	1700	T109	900
C28	1700	T12	900

3-15. RF Balance Adjustment

a. Connect the equipment as shown in figure 3-3. The schematic of the test jig is shown in figure 3-4.

b. Set the switches on the control unit as follows :

- (1) BFO-OFF switch to OFF.
- (2) Function switch to ANT.

c. Set the switches on the test set as follows :

- (1) DC POWER switch to ON.
- (2) RECEIVER-CONTROL switch to RECEIVER.
- (3) GONIO DRIVE switch to ON.

d. Set the range switch on the control unit to 190-400, and adjust the TUNE control on the control unit for 400 kHz on the FREQUENCY indicator.

e. Adjust the output of signal generator A to zero.

f. Set the frequency of signal generator B to 400 kc and the output to 100 microvolt, modulated 30 percent with 400 cps. Adjust the frequency of the signal generator for maximum indication on the audio output meter.

g. Adjust the GAIN control on the control unit for 20 mw on the audio output meter.

h. Set the frequency of signal generator A to 560 kc.

i. Set the frequency of signal generator B to 960 kc.

j. Adjust R136 full counterclockwise. Adjust the output of both signal generators to 100000 microvolt.

k. Adjust the frequency of signal generator A for maximum indication on the audio output meter.

NOTE

Do not change the setting of the GAIN control on the control unit.

l. Adjust the outputs (not the frequency) of both signal generators to equal levels to produce a 20-mw audio output on the audio output meter. The output of the two signal generators must be the same for this setting.

m. Adjust R136 (fig. 2-8) fully counterclockwise. Then adjust R136 five turns clockwise,

n. If necessary, adjust the outputs of both signal generators equally to indicate between 10 and 20 mw on the audio output meter.

o. Adjust R136 for minimum indication on the audio output meter.

NOTE

Balance (minimum audio output) should occur within three turns of the setting in m above.

3-16. First RF Amplifier Alignment

a. Connect the equipment as shown in figure 2-2.

b. Set the switches on the control unit as follows :

- (1) BFO-OFF switch to OFF.
- (2) Function switch to ANT.

c. Set the switches on the test set as follows:

- (1) DC POWER switch to ON.
- (2) RECEIVER-CONTROL switch to RECEIVER.
- (3) GONIO DRIVE switch to ON.

d. Set the range switch on the control unit to 190-400, and adjust the TUNE control on the control unit to 390 kc.

e. Modulate the signal generator 80 percent with 400 cps.

f. Set the frequency of the signal generator to 390 kc (the same as the receiver) as determined by a zero beat in the headset.

g. Disconnect the headset,

h. Adjust the loop simulator control on the test set so that the LOOP SIMULATOR indicator on the test set indicates 90° from the indication on the BEARING INDICATOR on the test set. Slightly adjust the loop simulator control for a maximum indication on the tuning meter on the control unit, Peaking of the tuning meter indicates maximum signal pickup.

i. Set the BFO-OFF switch on the control unit to OFF.

j. Set the GAIN control on the control unit to approximately three-fourths of the fully clockwise position.

k. Adjust the output of the signal generator for 20 mw on the audio output meter. Maintain this indication approximately throughout the procedures.

l. Unsolder and remove the cover of T1 (fig. 2-9 or 2-9.1).

m. Set the TUNE control on the control unit for 200 kc.

n. Set the frequency of the signal generator to 200 kc. Vary the frequency slightly in the vicinity of 200 kc, and note the maximum indication in db on the audio output meter.

o. Reconnect the headset to the test set, and adjust the frequency of the signal generator to 200 kc as determined by a zero beat in the headset.

p. Disconnect the headset, and note the indication in db on the audio output meter. This indication must be within 1 db of the indication noted in n above. If the difference is more than 1 db, proceed as follows:

- (1) Remove the cover of T1 (fig. 2-9 or 2-9.1).
- (2) Adjust the output of the signal gen-

erator for approximately 20 mw on the audio output meter.

- (8) Adjust T1 for a maximum indication on the audio output meter.
- (4) Repeat d through p above until no further adjustment is required.
- (6) Temporarily replace the cover of T1 (do not solder).
- (6) Repeak C2 at 890 kc.

q. Check that the screwdriver slot in C2 is not parallel to the front-to-rear axis of the receiver. If the screwdriver slot is parallel to this plane, readjust T1 at 200 kc. Then repeak C2 at 890 kc.

r. Repeat the procedures in b through q above for the capacitors (fig. 2-9 or 2-9.1) listed in the chart below. If necessary, adjust the corresponding transformer (fig. 2-9 or 2-9.1) for each capacitor according to the requirement of p above. Always disconnect the headset when observing the audio output meter.

Capacitor	Capacitor adjustment frequency setting (kc)	Coil	Coil adjustment frequency setting (kc)
C3	800	T2	420
C4	1700	T8	900

3-17. Audio and IF Gain Adjustment

- a. Connect the equipment as shown in figure 2-2.
- b. Set the switches on the control units as follows :
 - (1) BFO-OFF switch to BFO.
 - (2) Function switch to ANT.
 - (3) GAIN control fully clockwise.
- c. Set the switches on the test set as follows:
 - (1) DC POWER switch to ON.
 - (2) RECEIVER-CONTROL switch to RECEIVER.
 - (3) GONIO DRIVE switch to ON.
- d. Set the range switch on the control unit to 190-400, and adjust the TUNE control on the control unit to 200 kc.
- e. Modulate the signal generator output 30 percent with 400 cps, and adjust the output for 1000 microvolt.

f. Set the frequency of the signal generator to 200 kc (the same as the receiver) as determined by a zero beat in the headset.

g. Disconnect the headset.

h. Set the BFO-OFF switch on the control unit to OFF.

i. Adjust R82 (fig. 2-8) for 100 mw on the audio output meter. Then tighten the locknut on R82.

j. Adjust the output of the signal generator to 20 microvolt. Keep the modulation at 30 percent.

k. Adjust R90 (fig. 2-8) for 80 mw on the audio output meter. Then tighten the locknut on R90.

3-17.1 11 O-Hz Oscillator Frequency Adjustment

NOTE

Capacitors C151 and C153 are selected from 47 μ F, 56 μ F, 68 μ F, or 100 μ F to obtain a frequency of 110 \pm 6 Hz from the 110-Hz oscillator. This selection is necessary due to variations in components of the oscillator circuitry.

- a. Connect the equipment as shown in figure 2-2. It is not necessary to connect the signal generator, audio output meter, or headset.
- b. Set the switches on the control unit as follows:
 - (1) BFO-OFF switch to OFF,
 - (2) Function switch to ADF.
- c. Set the switches on the test set as follows:
 - (1) DC POWER switch to OFF.
 - (2) GONIO DRIVE switch to OFF.
 - (3) RECEIVER-CONTROL switch to RECEIVER.
- d. Refer to figure 2-7. Unsolder and disconnect the negative lead of capacitor C153.
- e. Select a capacitor combination listed in the chart below. Connect the capacitor combination between the positive leads of capacitors C151 and C153.

Capacitor combinations (μF)	Total series capacitance (μF)
47 and 47	23.5
17 and 56	25.6
47 and 68	27.8
56 and 56	28.0
56 and 68	30.7
47 and 100	32.0
68 and 68	34.0
56 and 100	46.0
68 and 100	40.5
100 and 100	50.0

f. Set test set DC POWER switch to ON.

g. Refer to figure 2-6. Connect frequency meter to positive lead of capacitor C68 and measure the frequency out of the 110-HZ oscillator. If the frequency is lower than 104 Hz, a capacitor combination with a lower total capacitance will be required. If the frequency is above 116 Hz, a capacitor combination with a higher total capacitance will be required. Several attempts may be necessary to determine which capacitor combination is capable of providing 110 ±6-Hz operation from the 110-HZ oscillator.

h. After the proper capacitor combination is determined, set test set DC POWER switch to OFF. Unsolder and remove old capacitors C151 and C153 and replace with selected values.

3-17.2. 90-Degree Phase Shift Adjustment

NOTE

Capacitor C82 is selected from 0.16 μF, 0.34 μF, 0.50 μF, or 0.75 μF to obtain a 90-degree phase shift between the 110-Hz oscillator and the loop servo amplifier. This selection is necessary due to variations in the components of the loop servo-amplifier circuitry.

a. Connect the equipment as shown in figure 2-2. It is not necessary to connect the audio output meter or headset.

b. Set the switches on the control unit as follows:

- (1) BFO-OFF switch to OFF.
- (2) Function switch to ADF.

c. Set the switches on the test set as follows:

- (1) DC POWER switch to OFF.
- (2) RECEIVER-CONTROL switch to RECEIVER.
- (3) GONIO DRIVE switch to ON.

d. Set the range switch on the control unit to 190-400, and adjust the TUNE control on the control unit to 200 kHz.

e. Adjust the frequency of the signal generator to 200 kHz, unmodulated, at an output level of 1000 microvolt.

f. Refer to figure 2-6. Connect the horizontal input of the oscilloscope to the positive lead of capacitor C68 and the vertical input to the collector of transistor Q24.

g. Adjust the vertical and horizontal sweep of the oscilloscope for the same amplitude.

h. Refer to figure 2-7. Unsolder and disconnect the negative lead of capacitor C82.

i. Select a value for C82 (0.16 μF, 0.35 μF, 0.50 μF, or 0.75 μF) and connect between the positive lead of capacitor C82 and ground.

j. Set test set DC POWER switch to ON. Observe the Lissajous pattern on the oscilloscope.

k. Repeat steps h through j to select a value of C82 that will provide the best circular Lissajous pattern on the oscilloscope.

l. After the proper capacitor value is determined, set the test set DC POWER switch to OFF. Unsolder and remove old capacitor C82 and replace with new value.

3-18. Adjustment and Synchronization of Resolver Servosystem

- a. Connect the equipment as shown in figure 2-2.
- b. Set the control unit switches as follows:
 - (1) BFO-OFF switch to BFO.
 - (2) Function switch to ADF.
 - (3) GAIN control fully clockwise.
- c. Set the test set switches as follows:
 - (1) RECEIVER-CONTROL switch to RECEIVER.
 - (2) GONIO DRIVE switch to ON.
 - (3) DC POWER switch to ON.
- d. Set the control unit range switch to 190-400, and adjust the control unit TUNE control to 990 kc on the FREQUENCY indicator.
- e. Set the frequency of the signal generator to 890 kc, unmodulated, at an output level of 1,000 microvolt.
- f. Adjust the frequency of the signal generator for a zero beat in the headset. Remove the headset from the test set.
- g. Set the BFO-OFF switch to OFF.
- h. Set the LOOP SIMULATOR to N (zero 0).
- i. Remove the two outside, rearmost screws on the top of the chassis; remove the two rearmost screws on the bottom of the chassis, and swing out the rear of the chassis.
- j. Loosen the three screws (51, fig. 5-16) just enough to rotate the body of B4 (60).
- k. Rotate the body of B4 until the test set BEARING INDICATOR indicates N (zero °).
- l. Set the control unit function switch to LOOP.
- m. Rotate the gears (94 and 96) on B3 (110) for a maximum indication on the output meter.
- n. Rotate the body of B4 until the test set BEARING INDICATOR again indicates N (zero °).
- o. Tighten the three screws (51) and secure the hinged portion of the receiver.

3-19. Servo Balance Adjustment

- a. Connect the equipment as shown in figure 2-2. It is not necessary to connect the signal generator, audio output meter, or headset.
- b. Set the switches on the control unit as follows:
 - (1) BFO-OFF switch to BFO.
 - (2) Function switch to ADF.
 - (3) GAIN control fully clockwise.
- c. Set the switches on the test set as follows:
 - (1) DC POWER switch to ON.
 - (2) RECEIVER-CONTROL switch to RECEIVER.
 - (3) GONIO DRIVE switch to ON.
- d. Set the range switch on the control unit to 190-400 and adjust the TUNE control on the control unit to 300 kc on the FREQUENCY indicator.
- e. Adjust R10 (fig. 2-8) so that the speed of rotation of the BEARING INDICATOR on the test set does not exceed 7200 in 2 minutes.
- f. Tighten the locknut of R10.

3-19.1 Slow Slew Speed Adjustment

NOTE

Resistor R133 is selected from 1500, 1800, 2200, 2700, or 3900 ohms to obtain the proper slow slew speed of the loop antenna. This selection is necessary due to variations in the components of the loop servo-amplifier circuitry

- a. Connect the equipment as shown in figure 2-2. It is not necessary to connect the signal generator, audio output meter, or headset.
- b. Set the switches on the control unit as follows:
 - (1) BFO-OFF switch to OFF.
 - (2) Function switch to LOOP.
- c. Set the test set switches as follows:
 - (1) DC POWER switch to OFF,

(2) GONIO DRIVE switch to ON.

d. Refer to figure 2-7 and note connections for resistor R133. Unsolder and disconnect both leads of R133.

e. Select a value for resistor R133 (1500, 1800, 2200, 2700, or 3900 ohms) and connect to terminals noted in step d.

f. Set the test set DC POWER switch to ON and the control unit LOOP L-R switch to the first detent toward R.

g. Record the time required for the test set BEARING INDICATOR to rotate 180 degrees clockwise.

h. Repeat steps e through g to select a value for R133 that will provide a slow slew speed of 24 to 36 seconds for a 180-degree clockwise rotation.

i. After the proper resistor value is determined, set the test set DC POWER switch to OFF. Replace R133 with new value.

3-20. Adjustment of Adf Hunt Control

a. Connect the equipment as shown in figure 2-2. It is not necessary to connect the audio output meter.

b. Set the switches on the control unit as follows :

- (1) BFO-OFF switches to BFO.
- (2) Function switch to ADF.
- (8) GAIN control fully clockwise.

c. Set the switches on the test set as follows:

- (1) DC POWER switch to ON.
- (2) RECEIVER-CONTROL switch to RECEIVER.
- (3) GONIO DRIVE switch to ON.

d. Set the 150PF-270PF switch on the sense antenna adapter to 150PF.

e. Set the range switch on the control unit to 190-400, and adjust the TUNE control on the control unit for 200 kc on the FREQUENCY indicator.

f. Adjust the output of the signal generator to 1000 microvolt, no modulation.

g. Adjust the frequency of the signal generator to 200 kc (the same as the receiver) as determined by a zero beat in the headset.

h. Set the BFO-OFF switch on the control unit to OFF.

i. Adjust the output of the signal generator to 40 microvolt.

j. Loosen the locknut on R131 (fig. 2-8).

k. Adjust R131 fully clockwise. The needle of the BEARING INDICATOR on the test set should fluctuate several degrees on either side of the actual indication.

Note. Resistor R131 is the adf hunt control. It is used to adjust the amount of adf needle activity (fluctuation about the actual bearing indication). When R131 is fully clockwise, the time required to obtain a bearing is minimum but the needle activity is maximum. As R131 is turned counterclockwise, the needle activity decreases, but the time required to obtain a bearing increases and the resolution (accuracy) of the indication may be degraded. The amount of needle activity can be set as desired m long as the resolution (l below) and the speed required to obtain an indication (m below) are within the prescribed limits.

L. Check. the resolution as follows:

- (1) Note the indication of the BEARING INDICATOR on the test set.
- (2) Adjust the LOOP control on the control unit to the L side, and then release the LOOP control. Note the indication of the BEARING INDICATOR when the needle of the BEARING INDICATOR resolves itself to its previous position.
- (3) Adjust the LOOP control to the R side, and then release the LOOP control. Note the indication of the BEARING INDICATOR when resolving is complete.
- (4) The indications in (2) and (3) above should not exceed the indication in (1) above by more than 2 degree.

m. Check the bearing speed as follows:

- (1) Adjust the TUNE control on the control unit for 300 kc.
- (2) Set the BFO-OFF switch on the control unit to BFO.
- (9) Adjust the frequency of the signal generator to 300 kc as determined by a zero beat in the headset. It may be necessary to increase the output level of the signal generator while zero beating.

- (4) Set the BFO-OFF switch on the control unit to OFF.
- (5) Adjust the output of the signal generator to 40 microvolts.
- (6) Set the function switch on the control unit to LOOP.
- (7) Note the indication of the BEARING INDICATOR on the test set.
- (8) Adjust the LOOP control on the control unit so that the indication on the BEARING INDICATOR is 175 degrees to the right or left of the indication in (7) above.
- (9) Observe the BEARING INDICATOR, return the function switch on the control unit to ADF, and measure the time required for the BEARING INDICATOR to reposition at the indication in (7) above.
- (10) The time required in (9) above should not exceed 7 seconds.

n. If necessary, readjust R131 to meet the requirements of l and m above. Then tighten the locknut on R131.

3-21. Inverter Voltage Adjustment

- a. Remove two screws which secure the protective plate marked INVERTER on the front panel of the test set.
- b. Disconnect the inverter which is normally part of the test set.
- c. Connect cable W4 of the test set between P1 on the inverter and the connector marked INVERTER on the test set.
- d. Connect cable W1 of the test set between J7 on the test set and a 27.5-volt dc power source.
- e. Set the DC POWER switch on the test set to ON.
- f. Set the RECEIVER-CONTROL switch on the test set to CONTROL.
- g. Connect the ac voltmeter to the test point located in the center of the 1A fuse holder cap on the test set.
- h. Loosen the locknut on R1 (fig. 2-25) on the inverter, and adjust R1 for an indication of 26 ± 2.0 volts on the ac voltmeter.
- i. Tighten the locknut on R1.

3-21.1. Inverter Frequency Adjustment

NOTE

Capacitor C6 is selected from 2.2 μ F, 3.3 μ F, 3.9 μ F, 4.7 μ F, 6.8 μ F, or 10 μ F to obtain a frequency of 400 ± 40 Hz from the inverter. This selection is necessary due to variations in components of the inverter circuitry.

- a. Remove two screw's that secure the protective plate marked INVERTER on the front panel of the test set.
- b. Disconnect the inverter that is normally part of the test set.
- c. Connect cable W4 of the test set between P1 on the inverter and the connector marked INVERTER on the test set.
- d. Connect cable W1 of the test set between J7 on the test set and a +27.5-volt dc power source.
- e. Set the test set RECEIVER-CONTROL switch to CONTROL.
- f. Connect the frequency meter to the test point located in the center of the 1A fuseholder cap on the test set.
- g. Refer to figure 2-2.5. Loosen the locknut on R1 and position R1 fully clockwise.
- h. Refer to figure 2-25 and note connections for capacitor C6. Unsolder and disconnect both leads of C6.
- i. Select a value for C6 (2.2 μ F, 3.3 μ F, 3.9 μ F, 4.7 μ F, 6.8 μ F, or 10 μ F) and connect to terminals noted in step h.
- j. Set the test set DC POWER switch to ON and note frequency on frequency meter,
 - li. Repeat steps i and j to select a value for C6 that will provide a frequency of 400 ± 40 Hz from the inverter.
 - l. After the proper capacitor value is determined, set the test set DC POWER switch to OFF. Replace C6 with the new value.
- m. Remove the frequency meter and connect the ac voltmeter to the same test point.

n. Set the test set DC POWER switch to ON, and adjust R1 for an indication of 26 ± 2.0 volts on the ac meter.

o. Set the test set DC POWER switch to OFF, and tighten the locknut on R1.

3-22. Control Unit Alignment

NOTE

Refer to figure 5-17 throughout the alignment of the control unit.

a. Vertical Alignment of Dial Drum.

(1) Set the range switch to 190-400.

(2) Loosen two setscrews (78) and rotate collar (77) until the band markings around the top of dial drum (41) are clearly visible through the FREQUENCY window on front panel (93). Tighten one of the setscrews (78).

(3) Rotate the TUNE knob (97) in either direction. If the bottom of the dial drum (41) rubs frame (136) loosen the one setscrew (78) and readjust collar (77) until dial drum (41) no longer rubs frame (136). Tighten two setscrews (78).

(4) Set the range switch to 840-1750,

(5) Rotate the TUNE knob (97) in either direction. The band markings around the bottom of dial drum (41) should be clearly visible through the FREQUENCY window on front panel (93), and the top of dial drum (41) should not rub frame (136). If necessary, loosen two setscrews (78) to readjust collar (77).

(6) Set the range switch to 190-400, and repeat (3) above.

b. Dial Drum Rotational Limits.

(1) Set range switch to 850-1750.

(2) Rotate the tune control clockwise. Loosen setscrews (44) and rotate gear (43) until alignment mark on dial drum is aligned with hairline on glass frequency window. Tighten setscrews.

(3) Loosen two setscrews (71), and rotate the TUNE control to the maximum counterclockwise position.

(4) Apply blue varnish to the threads of two setscrews (71).

(5) Tighten two setscrews (71).

c. Alignment of Tuning Synchro.

(1) Remove the control unit contained in the test set.

(2) Connect P1 of the test set to P301 of the control unit to be checked. Keep the control unit outside the test set.

(3) Connect the test set to the equipment as shown in figure 2-19.

(4) Set the function switch on the control unit to ADF.

(5) Set the range switch on the control unit to 840-1750.

(6) Rotate the TUNE control until the small circle between 1,400 and 1,500 kc is bisected by the hairline in the frequency window.

(7) Set the RECEIVER-CONTROL switch on the test set to CONTROL.

(8) Set the POWER switch on the test set to ON. (All other switches and controls on the control unit and the test set may be in any position.)

NOTE

In (9) below, do not allow spur gear (122) or spur gear (123) to become disengaged with spur gear (120). Disengagement will cause loss of spring loading between spur gears (122, 123). Refer to paragraph 3-6c to restore spring loading.

(9) Loosen two setscrews (127), and use a narrow-bladed screwdriver to rotate the shaft on transmitter synchro (156) until the BEARING INDICATOR on the test set indicates exactly 239 degrees,

(10) Apply blue varnish to the threads of two setscrews (127).

(11) Tighten two setscrews (127).

(12) To check the accuracy of the transmitter synchro, perform the procedures in (a) and (b) below.

(a) Rotate the TUNE control until 1,700 kc is indicated in the FREQUENCY window. The BEARING INDICATOR on the test set should indicate 203 ± 1.0 degrees.

(b) Rotate the TUNE control until 850 kc is indicated in the FREQUENCY window, The BEARING INDICATOR on the test set should indicate 343 ± 1.0 degrees.

(13) Set the POWER switch on the test set to OFF.

(14) Disconnect P1 on the test set from P301 on the control unit.

(15) Install original control unit in the test set.

CHAPTER 4 GENERAL SUPPORT AND DEPOT INSPECTION PROCEDURES

Section 1. GENERAL SUPPORT

4-1. General

a. Test procedures are prepared for use by Signal field maintenance shops and Signal service organizations responsible for general support maintenance of electronic equipment to determine the acceptability of repaired electronic equipment. These procedures set forth specific requirements that repaired electronic equipment must meet before it is returned to the using organization. The test procedures may also be used as guide for the testing of equipment that has been repaired at direct support maintenance if the proper tools and test equipments are available. A summary of the performance standards is given in paragraph 4-19.

b. Comply with the instructions preceding the body of each chart before proceeding to the chart. Perform each test in sequence. Do not vary the sequence. For each step, perform all the actions required in the Test equipment control settings and Equipment under test control settings columns; then perform each specific test procedure and verify it against its performance standard.

4-2. Test Equipment, Tools, and Materials Required

a. Test Equipment.

Nomenclature	Federal Stock No.	Technical Manual
Test Set, Direction Finder Set AN/ARM-93.		TM 11-6625-821-12
RF Signal Generator AN/URM-25 ().		TM 11-5551
Multimeter TS-352/U.		TM 11-5527
Headset, 600-ohms impedance.		

Nomenclature	Federal Stock No.	Technical Manual
Frequency Meter AN/USM-26 or 207 ().		TM 11-5057
Output Meter TS-585A/U.		TM 11-5017
Q Meter TS-617 U.		

b. *Tools.* No special tools are required.

c. *Materials.* Stopwatch.

4-3. Test Facilities

A dc power source of + 27.5 volts capable of supplying a current of 2 amperes is required to furnish the operating voltages for the receiver through Test Set, Direction Finder Set AN/ARM-93. The negative side of the dc power source shall be grounded. If a battery eliminator is used, the peak ac ripple voltage shall not exceed 1.4 volt rms. Unless otherwise specified, all test procedures shall be performed under the following conditions:

a. *Test Requirements.* With the exception of physical tests, all performance tests are to be conducted with the receiver connected to, and or the inverter and control unit installed in, Test Set, Direction Finder Set AN/ARM-93 as shown in the illustrations associated with the following charts.

b. *External RF Interference.* Radiated electromagnetic fields in the test area shall not exceed 10,000 microvolt per meter in the frequency range of 100 kc to 3,000 kc.

4-4. Modification Work Orders

The performance standards listed in the tests (paras 4-5 through 4-18) are based on the assumption that applicable modification work orders have been performed.

4-5. Direction Finder Control C-6899/ARN-83 Physical Tests and Inspection

a. *Test Equipment and Materials.* None required.

b. *Test Connections and Conditions.* Remove control unit from case.

c. *Procedure.*

Step	Test equipment control settings	Equipment under test control settings	Test procedure	Performance standard
1	N/A	Controls may be in any position.	<p>a. Inspect all controls and mechanical assemblies for loose or missing screws, bolts, or nuts.</p> <p>b. Inspect dial lights and rear connector for looseness and damage.</p> <p>c. Inspect tuning meter face for scratches or broken glass.</p> <p>d. Inspect case and chassis for damage, missing parts, and condition of finish. Inspect condition of finish and lettering on front panel.</p> <p><i>Note.</i> Touchup painting is recommended in lieu of refinishing whenever practicable. Screw heads, binding posts, connectors, and plated fastener parts will not be painted or polished with abrasives.</p>	<p>a. Screws, bolts, and nuts will be tight; none missing.</p> <p>b. No looseness or damage evident.</p> <p>c. No scratches or broken glass evident.</p> <p>d. No damage or missing parts evident. External surfaces intended to be painted will not show bare metal. Panel lettering will be legible.</p>
2	N/A	Controls may be in any position.	<p>a. Turn LOOP switch to first position R (right) or L (left) and release knob.</p> <p>b. Turn LOOP switch to second position R (right) or L (left) and release knob.</p> <p>c. Set BFO OFF switch to BFO and OFF positions.</p> <p>d. Rotate function switch to ADF, ANT, and LOOP positions and back to OFF.</p> <p>e. Rotate range switch to all frequency range positions.</p> <p>f. Rotate GAIN and TUNE controls throughout their limits of travel.</p>	<p>a. Operates freely without binding or excessive looseness; spring-return to center position. Switch will have positive detent action.</p> <p>b. Same as a above. Switch stops will be encountered at extreme right and left positions.</p> <p>c. Operates freely to BFO and OFF.</p> <p>d. Operates freely without binding and rubbing against panel or excessive looseness. Switch will have positive detent action.</p> <p>e. Same as d above.</p> <p>f. Controls rotate freely without binding or excessive looseness.</p>
3	N/A	N/A	Check control unit for applicable modification work orders (see para 4-4).	None.

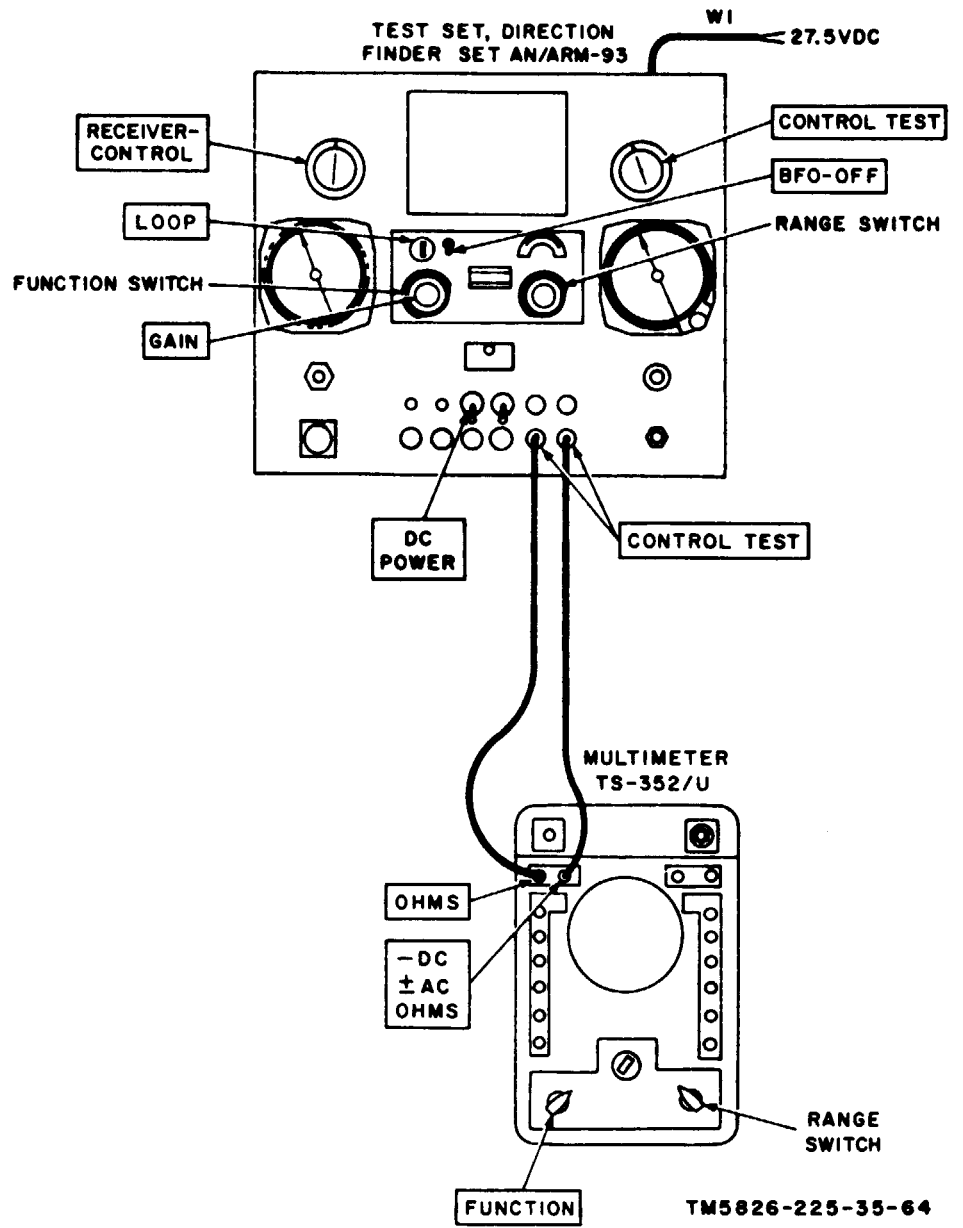

Figure 4-1. Control unit test.

4-6. Control Unit Test

a. Test Equipment and Materials.

- (1) Test Set, Direction Finder Set AN/ARM-93.
- (2) Multitester TS-352/U.

b. Test Connections and Conditions. Set test set DC POWER switch to OFF position. Set RECEIVER-CONTROL to CONTROL position. Replace case of control unit and mount control unit in panel of test set. Connect TS-352/U as shown in figure 4-1.

c. Procedure.

Step	Test equipment control settings	Equipment under test control settings	Test procedure	Performance standard
1	AN/ARM-93 CONTROL TEST: 1 TS-352/U FUNCTION: OHMS. Range: As required.	C-6899/ARN-83 Set the range switch to 850-1750 position.	<ol style="list-style-type: none"> a. Set TS-352/U range switch to RX1 b. Turn C-6899/ARN-83 LOOP switch to second detent position R (right) and then to L (left). c. Set TS-352/U to RX100. Turn LOOP switch to first position R (right) and then to L (left). d. Tune control unit frequency indicator to 850 cps. e. Tune control unit frequency indicator so that hairline bisects small circle located between 1,400 and 1,500 cps. f. Tune control unit frequency indicator to 1700 cps. g. Note tuning meter . 	<ol style="list-style-type: none"> a. TS-352/U will indicate 1 ohm or less. b. TS-352/U will indicate 1 ohm or less for each position. c. TS-352/U will indicate 4,700 ohms $\pm 10\%$ for each position. d. AN/ARM-93 bearing indicator should indicate $342 \pm 2^\circ$. e. AN/ARM-93 bearing indicator should indicate $239 \pm 2^\circ$. f. AN/ARM-93 bearing indicator should indicate $203 \pm 2^\circ$. g. Control unit tuning meter should indicate half scale.
2	AN/ARM-93 CONTROL TEST: 2 TS-352/U No change from step 1.	C-6899/ARN-83 Same as step 1.	<ol style="list-style-type: none"> a. Set TS-352/U range switch to RX1. Set control unit BFO-OFF switch to BFO. b. Set TS-352/U to RX100. Set control unit BFO-OFF switch to OFF. 	<ol style="list-style-type: none"> a. TS-352/U will indicate 1 ohm, or less. b. TS-352/U will indicate infinity.
3	AN/ARM-93 CONTROL TEST: 3 TS-352/U FUNCTION: OHMS. Range: RX10	C-6899/ARN-83 Same as step 1.	<ol style="list-style-type: none"> a. Set control unit function switch to ADF b. Set control unit function switch to ANT. Slowly adjust GAIN control between extreme counter-clockwise (ccw) and clockwise (cw) positions. c. Set control unit function switch to LOOP. Adjust GAIN control as in step b above. 	<ol style="list-style-type: none"> a. TS-352/U will indicate 1 ohm, or less. b. TS-352/U will indicate from $5,000 \pm 10\%$ ohm to 25 ohms, or less. c. TS-352/U will indicate from $470 \pm 10\%$ to $5,470 \pm 10\%$ ohms.

Change 4 4-5

TM 11-5826-225-35

Step	Test equipment control settings	Equipment under test control settings	Test procedure	Performance standard
4	AN/ARM-93 CONTROL TEST: 4 <i>TS-352/U</i> No change from step 3.	C-6899/ARN-83 Same as step 1....	a. Turn control unit GAIN control to extreme ccw position. Set function switch to ADF or ANT. b. Set function switch to LOOP	a. TS-352/U will indicate 5,000 \pm 10% ohms for ADF or ANT. b. TS-352/U will indicate approximately 5,500 \pm 10% ohms.
5	AN/ARM-93 CONTROL TEST: 5 <i>TS-352/U</i> No change from step 3.	C-6899/ARN-83 Same as step 1....	a. Set control unit function switch to ANT or LOOP. b. Set function switch to ADF. Slowly adjust GAIN control between extreme ccw and cw positions.	a. TS-352/U will indicate 1 ohm or less for ANT or LOOP. b. TS-352/U will indicate 1300 \pm 10% ohms to 25 ohms or less.
6	AN/ARM-93 CONTROL TEST: 6 <i>TS-352/U</i> No change from step 3.	C-6899/ARN-83 Same as step 1....	a. Set function switch to ADF. Set the control unit GAIN control fully counter-clockwise. b. Set function switch to ANT or LOOP	a. TS-352/U will indicate 650 \pm 10% ohms. b. TS-352/U will indicate infinity for ANT or LOOP.
7	AN/ARM-93 CONTROL. TEST: 7 <i>TS-352/U</i> FUNCTION: OHMS. Range: RX1	C-6899/ARN-83 Same as step 1....	a. Set control unit function switch to OFF	a. TS-352/U will indicate infinity.
8	AN/ARM-93 CONTROL TEST: 8 <i>TS-352/U</i> No change from step 7.	C-6899/ARN-83 Same as step 1....	a. Set control unit function switch to ADF	a. TS-352/U will indicate infinity.
9	AN/ARM-93 CONTROL TEST: 9 <i>TS-352/U</i> No change from step 7.	C-6899/ARN-83 Same as step 1....	a. Set control unit function switch to ANT	a. TS-352/U will indicate infinity.
10	AN/ARM-93 CONTROL	C-6899/ARN-83 Same as step 1....	a. Set control unit function switch to LOOP. ...	a. TS-352/U will indicate infinity.

	TEST: 10 TS-352/U No change from step 7.		b. Set function switch to ADF and ANT positions.	b. TS-352/U will indicate 1 ohm, or less, for each position.
11	AN/ARM-93 CONTROL TEST: 11 TS-352/U No change from step 7.	C-6899/ARN-83 Same as step 1....	a. Set control unit range switch to 190-400 position. b. Set range switch to the 400-850 and 850-1750 positions.	a. TS-352/U will indicate 25 ±10% ohms. b. TS-352/U will indicate 1 ohm, or less, for each position.
12	AN/ARM-93 CONTROL TEST: 12 TS-352/U No change from step 7.	C-6899/ARN-83 Same as step 1....	a. Set control unit range switch to the 400-850 position. b. Set range switch to the 190-400 and 850-1750 positions.	a. TS-352/U will indicate 25 ±10% ohms. b. TS-352/U will indicate 1 ohm, or less, for each position.
13	AN/ARM-93 CONTROL TEST: 13 TS-352/U No change from step 7.	C-6899/ARN-83 Same as step 1....	a. Set control unit range switch to the 850-1750 position. b. Set range switch to the 190-400 and 400-850 positions.	a. TS-352/U will indicate 25 ±10% ohms. b. TS-352/U will indicate 1 ohm, or less, for each position.
14	AN/ARM-93 CONTROL TEST:2 TS-352/U No change from step 7.	C-6899/ARN-83 Same as step 1.....	a. Set Frequency Indicator on C-6899/ARN-83 so it bisects the small circle located between 1400 and 1500 kc. b. Set Frequency Indicator to 1700 kc. c. Set Frequency Indicator to 850 kc.	a. AN/ARM-93 bearing indicator should indicate 239 ± 2°. b. AN/ARM-93 bearing indicator should indicate 203 ±2°. c. AN/ARM-93 bearing indicator should indicate 343 ±2°.

Change 4 4-6.1

TN 11-5826-225-35

4-7. Radio Receiver R-1391/ARN-83 Physical Tests and Inspection

- a. Test Equipment and Materials. None required.
 b. Test Connections and Conditions. Remove receiver from case.
 c. Procedure.

Step	Test equipment, special settings	Equipment under test	Test procedure	Performance standards
1	N/A	N/A	a. Inspect all subassemblies for loose or missing screws, bolts, and nuts securing subassemblies. All bolts, nuts, and screws shall be tight, none missing. b. Inspect insulation of wiring for cuts, pinches, and signs of burning. c. Inspect transformer sockets for cracks and loose ends. No cracks or loose connections evident. d. Check that nuts on top of all power transformers are tight and none missing. e. Inspect more insulating washers between power transformer and chassis for cracks. f. Check condition for cracks and signs of burning. g. Inspect all insulated terminal studs for looseness and signs of damage. h. Inspect sockets of sockets for cracks, bent contacts, and corrosion. i. Inspect switch shaft coupling spring for looseness and damage. j. Inspect connections at front and rear of receiver for bent pins, bent shells, and cracked insulation material. k. Inspect soldered connections for cold-soldered connections. l. Check that all metal covers are soldered securely to ends of RF coils (right side of receiver); none missing. m. Inspect gear trains for broken or missing anti-backlash springs.	a. No cracks or loose connections evident. b. No signs of cracks or burning evident. c. No looseness or damage evident. d. No cracks, bent contacts or corrosion evident. e. No looseness or damage evident. f. No bent pins, bent shells, or cracked insulation evident. g. No cold-soldered connections evident. h. Coil covers secure and none missing. i. No broken or missing springs evident.
2	N/A	N/A	a. Inspect receiver chassis and subassemblies for signs of corrosion. b. Inspect front of receiver and case for damage and condition of finish. c. Inspect interior of case for damage and condition of finish.	a. No corrosion evident. b. External surfaces intended to be painted will not show bare metal.
3	N/A	N/A	Check receiver for applicable modification work orders (para 4-4).	None.

11-4830-9086-11 14

4-7. Radio Receiver R-1391/ARN-83 Physical Tests and Inspection

- a. Test Equipment and Materials. None required.
 b. Test Connections and Conditions. Remove receiver from case.
 c. Procedure.

Step	Test equipment, special settings	Equipment under test, test conditions	Inspection	Performance standards
1	N/A	N/A	a. Inspect all subassemblies for loose or missing screws, bolts, and nuts securing subassemblies. All bolts, nuts, and screws shall be tight, none missing. b. Inspect insulation of wiring for cuts, pinches, and signs of burning. c. Inspect transformer sockets for cracks and loose connections. d. Check that nuts on top of all power transformers are tight and none missing. e. Inspect more insulating washers between power transformer and chassis for cracks. f. Check condition for cracks and signs of burning. g. Inspect all insulated terminal studs for looseness and signs of damage. h. Inspect sockets of sockets for cracks, bent contacts, and corrosion. i. Inspect switch shaft coupling spring for looseness and damage. j. Inspect connections at front and rear of receiver for bent pins, bent shells, and cracked insulation material. k. Inspect soldered connections for cold-soldered connections. l. Check that all metal covers are soldered securely to ends of RF coils (right side of receiver); none missing. m. Inspect gear trains for broken or missing anti-backlash springs.	1. No cracks or loose connections evident. 2. No signs of cracks or burning evident. 3. No looseness or damage evident. 4. No cracks, bent contacts or corrosion evident. 5. No looseness or damage evident. 6. No bent pins, bent shells, or cracked insulation evident. 7. No cold-soldered connections evident. 8. Coil covers secure and none missing. 9. No broken or missing springs evident.
2	N/A	N/A	a. Inspect receiver chassis and subassemblies for signs of corrosion. b. Inspect front of receiver and case for damage and condition of finish. c. Inspect receiver for damage to case of metal parts, wherever practicable, from loose bolts, nuts and pins; however parts on chassis will not be painted or painted with alternate color.	1. No corrosion evident. 2. External surfaces intended to be painted will not show bare metal.
3	N/A	N/A	Check receiver for applicable modification work orders (para 4.4).	None.

11-4830-9086-11 14

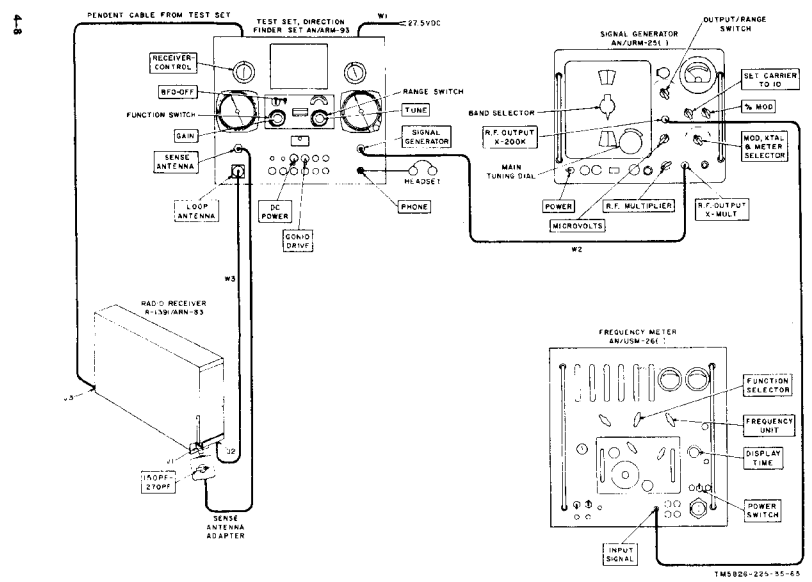

Figure 1-2. Receiver frequency accuracy test.

TM 11-5584-223-33

1M5924-223-33-64

4-8. Receiver Frequency Accuracy Test

- a. Test Equipment and Materials
 (1) Test Set, Direction Finder Set AN/ARM-83.
 (2) Signal Generator AN/URM-25().
 (3) Frequency Meter AN/USM-26().
 (4) Headset.

b. Test Connections and Conditions. Connect the test equipment as shown in figure 4-2. Turn on the equipment and allow a 5-minute warmup before proceeding.

c. Procedure.

Step	Test equipment and materials	Equipment connections	Test procedure	Performance standard
1	AN/ARM-83 DC POWER ON GONIO DRIVE ON RECEIVER CONTROL RECEIVES Function switch: ANT Range switch: 100-400 BFO-OFF: BFO GAIN: As required TUNE: 200 kc on KHz-CYCLES indicator AN/URM-25() TUNER ON Band selector: 90-300 KC Main tuning dial: 200 kc on KHz-CYCLES indicator SET CARRIER TO 10 Fully cw 10 MOD: Fully cw MICROVOLTS: Fully cw MOD, XTAL AND METER SELECTOR: CW Output range switch: X-MULT is 10 KC-300 KC range R.F. MULTIPLIER: 10 Some antenna adapter 100PP-200PP SWP AN/URM-25() POWER switch ON FUNCTION SELECTOR FREQUENCY FREQUENCY UNIT: 1 DISPLAY TIME: As desired.	N/A	1. Set the AN/URM-25() for 20 microvolts, modulated 30 percent at 400 cps. Monitor the AN/URM-25() output frequency with the AN/USM-26(). Tune AN/URM-25() for accuracy in headset and note frequency readout on AN/USM-26(). 2. Repeat above procedure, except at AN/ARM-93 and AN/ARM-25 to 400 kc.	1. Frequency readout on the AN/USM-26() will be 200 ± 0.5 kc. 2. Frequency readout on AN/USM-26 will be 400 ± 0.5 kc.
2	Controls will be the same as in step 1 above except as follows: AN/ARM-83 Range switch: 400-800 TUNE: 400 kc on FREQUENCY indicator AN/URM-25() Band selector: 90-300 KC Main tuning dial: 400 kc on KHz-CYCLES indicator Output range switch: X-MULT is 300 KC-600 KC range	N/A	1. Same as step 1, except set AN/ARM-93 and AN/ARM-25 to 400 kc. 2. Same as step 1, except set AN/ARM-93 and AN/ARM-25 to 700 kc.	1. Frequency read-out on the AN/USM-26() will be 400 ± 0.5 kc. 2. Frequency readout on AN/USM-26 will be 700 ± 0.5 kc.
3	Controls will be the same as in step 1 above except as follows: AN/ARM-83 Range switch: 800-1750 kc TUNE: 1,000 kc on FREQUENCY indicator AN/URM-25() Band selector: 90-300 KC Main tuning dial: 1 mc on MEGA-CYCLES indicator Output range switch: X-MULT is 300 KC-30 MC range	N/A	1. Same as step 1, except set AN/ARM-93 and AN/ARM-25 to 1,000 kc. 2. Same as step 1, except set AN/ARM-93 and AN/ARM-25 to 1,700 kc.	1. Frequency read-out on the AN/USM-26() will be 1,000 ± 10 kc. 2. Frequency readout on AN/USM-26 will be 1,700 ± 10 kc.

4-9. Receiver Bandwidth Test

- a. Test Equipment and Materials.
 (1) Test Set, Direction Finder Set AN/ARM-93
 (2) Signal Generator AN/URM-25()
 (3) Frequency Meter AN/UM-26()
 (4) Output Meter TS-585A/U.
 (5) Headset.

b. Test Connections and Conditions. Connect the test equipment as shown in figure 4-3. Turn on the equipment and allow a 5-minute warmup before proceeding.

c. Procedure.

Step	Test equipment and conditions	Procedure	Test results	Performance standard
1	AN/ARM-93 DC POWER ON GOTO DRIVE: OFF RECEIVER CONTROL: RECEIVER Function switch: ANT Range switch: 800-1500 BFO-OFF: BFO GAIN: As required TUNE: 1300 kc on FREQUENCY indicator AN/URM-25() POWER ON Band selector: 30-23 MC Main tuning dial: 100 kc on the MEGACYCLES indicator SET CARRIER TO 20: Fully cw 5. MOD: Fully cw MICROPOS: Fully cw MOD. XTAL & METER SELEC- TOR: CW Output/range switch: X-MULT in 300 kc- 50 mc range B.F. MULTIPLIER X10 Sense antenna adapter 100PF-200PF: 150PF AN/USM-84() Power switch: ON FUNCTION SELECTOR: FREQUENCY FREQUENCY UNITS: 1 DISPLAY TIME: As desired TS-585A/U Impedance control: 60X10 Meter multiplier: 10	N/A	a. Set the AN/URM-25() for 100 microvolts, modulated 50 percent at 475 cps. Monitor the AN/URM-25() output frequency with the AN/URM-25() Tune AN/URM-25() for 200 kc and on handset, then set BFO-OFF switch on the AN/ARM-93 to OFF. Remove the headset. Adjust GAIN control on the AN/ARM-93 for indication of 20 milliwatts on the TS-585A/U. b. Increase AN/URM-25() output to 200 microvolts (6-db increase). Tune AN/URM-25() above 1,300 kc until indication on the TS-585A/U drops to 20 milliwatts. Record the signal generator frequency above 1,300 kc as F1. Turn the AN/URM-25() below 1,300 kc until indication on the TS-585A/U drops to 20 milliwatts. Record the signal generator frequency below 1,300 kc as F2. Subtract frequency F2 from frequency F1 to obtain the 6-db bandwidth. c. Decrease the AN/URM-25() to 1,300 kc. Increase AN/URM-25() output to 100-200 microvolts (6-db increase). Tune AN/URM-25() above 1,500 kc until indication on the TS-585A/U drops to 20 milliwatts. Record the signal generator frequency above 1,500 kc as F1. Turn AN/URM-25() below 1,500 kc until indication on the TS-585A/U drops to 20 milliwatts. Record the signal generator frequency below 1,500 kc as F2. Subtract frequency F2 from frequency F1 to obtain the 60-db bandwidth.	a. None. b. The bandwidth will be not less than 2.3 kc. c. The bandwidth shall not exceed 11 mc.
2	Controls will be the same as in step 1 above except as follows: AN/ARM-93 Range switch: 100-400 TUNE: 200 kc on FRE- QUENCY indicator AN/URM-25() Band selector: 30-30KC Main tuning dial: 200 kc on K110- CYCLES indicator Output range switch: X-MULT in 100K- 500K range	N/A	a. Connect the headset and make sure that BFO-OFF switch on the AN/ARM-93 is set to BFO. Repeat procedure in above. b. Increase AN/URM-25() output to 200 microvolts (6-db increase). Tune AN/URM-25() above 200 kc until indication on TS-585A/U drops to 10 milliwatts. Record the signal generator frequency above 200 kc as F1. Turn the AN/URM-25() below 200 kc until indication on the TS-585A/U drops to 10 milliwatts. Record the deviation of signal generator frequency below 200 kc as F2. Subtract frequency F2 from frequency F1 to obtain the 6-db bandwidth. c. Reduce the AN/URM-25() to 250 kc. Increase AN/URM-25() output to 100,000 microvolts (60-db increase). Tune AN/URM-25() above 200 kc until indication on the TS-585A/U drops to 10 milliwatts. Record the signal generator frequency above 200 kc as F1. Turn the AN/URM-25() below 200 kc until indication on the TS-585A/U drops to 10 milliwatts. Record the signal generator frequency below 200 kc as F2. Subtract frequency F2 from frequency F1 to obtain the 60-db bandwidth.	a. None. b. The bandwidth shall be not less than 2.3 kc. c. The bandwidth will not exceed 10 kc.

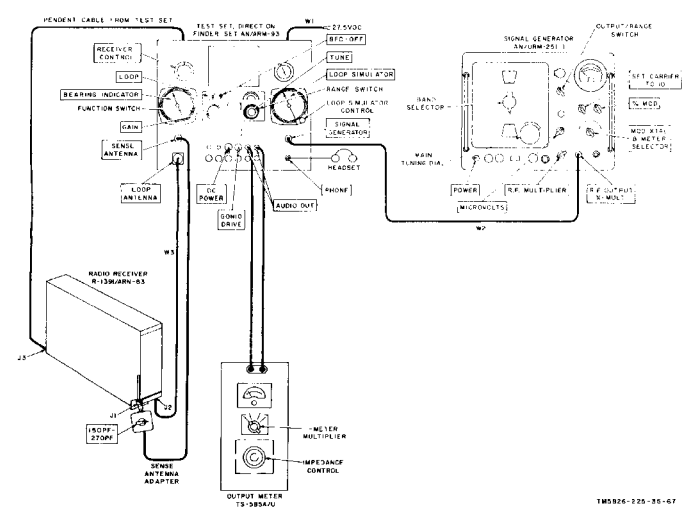

Figure 4-1. Receiver sensitivity test.

TM 9-120-10-17

88-100-100-11-101

4-10. Receiver Sensitivity, Bearing Threshold, and Audio Output Test

a. Test Equipment and Materials.

- (1) Test Set, Direction Finder Set AN/ARM-93.
- (2) Signal Generator AN/URM-25().
- (3) Output Meter TS-585A/U.
- (4) Headset.
- (5) Stopwatch.

b. Test Connections. Connect the test equipment as shown in figure 4-4. Turn on the equipment and allow a 5-minute warm-up before proceeding.

c. Procedure.

Step	Test equipment control settings	Equipment under test control settings	Test procedure	Performance standard												
1	AN/ARM-93 DC POWER: ON GONIO DRIVE: OFF RECEIVER-CONTROL: RECEIVER Function switch: ANT Range switch: 190-400 BFO-OFF: BFO GAIN: Fully cw TUNE: 200 kc on FREQUENCY indicator AN/URM-25() POWER: ON Band selector: 95-300KC Main tuning dial: 200 kc on KILO-CYCLES indicator Output/range switch: X-MULT in 10KC-800KC range. SET CARRIER TO 10: Fully ccw MICROVOLTS: Fully cw MOD, XTAL & METER	N/A	<p><i>a.</i> Set the AN/URM-25() for 50 microvolts unmodulated. Tune AN/URM-25() for zero beat in headset, then set BFO-OFF switch on the AN/ARM-93 to OFF. Remove the headset. Set the AN/URM-25() for 50 microvolts, modulated 30 percent at 400 cps. Adjust GAIN control on the AN/ARM-93 for indication of 20 milliwatts on the TS-585A/U. Remove the AN/URM-25() modulation and note the decrease in the TS-585 A/U indication.</p> <p><i>b.</i> Set the AN/ARM-93 and AN/URM-25() to each of the frequencies listed below and repeat procedure <i>a</i> above. Set the AN/URM-25() for the output level listed below rather than for 50 microvolts as listed in <i>a</i> above.</p> <table style="margin-left: auto; margin-right: auto;"> <thead> <tr> <th>Frequency in kc</th> <th>Output level in μw</th> </tr> </thead> <tbody> <tr> <td>390</td> <td>25</td> </tr> <tr> <td>420</td> <td>35</td> </tr> <tr> <td>800</td> <td>20</td> </tr> <tr> <td>900</td> <td>25</td> </tr> <tr> <td>1,700</td> <td>22</td> </tr> </tbody> </table>	Frequency in kc	Output level in μ w	390	25	420	35	800	20	900	25	1,700	22	<p><i>a.</i> The TS-585A/U indication should decrease at least 6 db.</p> <p><i>b.</i> Same as <i>a</i> above.</p>
Frequency in kc	Output level in μ w															
390	25															
420	35															
800	20															
900	25															
1,700	22															

Change 1 4-13

TM 11-5826-225-35

Step	Test equipment control settings	Equipment under test control settings	Test procedure	Performance standard												
	SELECTOR: CW R.F. MULTIPLIER: X10 <i>Sense antenna adapter</i> 150PF-270PF: 150PF <i>TS-585A/U</i> Impedance control: 60X10 Meter multiplier: 10															
2	AN/ARM-93 Same as step 1 above except set GONIO DRIVE to ON and function switch to LOOP. AN/URM-25() No change from step 1. <i>Sense antenna adapter</i> No change from step 1. <i>TS-558A/U</i> No change from step 1.	N/A	<p>a. Set AN/ARM-93 loop simulator control for an indication on LOOP SIMULATOR meter that is 90 degrees greater than on the BEARING INDICATOR meter. Set the AN/URM-25() for 100 microvolts unmodulated. Tune AN/URM-25() for zero beat in headset, then set BFO-OFF switch on the AN/URM-93() to OFF. Remove the headset. Set the AN/URM-25() for 125 microvolts, modulated 30 percent at 400 cps. Adjust GAIN control on the AN/ARM-93 for indication of 20 milliwatts on the TS-585A/U. Remove the AN/URM-25() modulation and note the decrease in the TS-585A/U indication.</p> <p>b. Set the AN/ARM-93 and AN/URM-25() to each of the frequencies listed below and repeat a above. Set the AN/URM-25() for the output level listed below rather than for 100 microvolts as listed in a above.</p> <table style="margin-left: auto; margin-right: auto;"> <thead> <tr> <th style="text-align: center;">Frequency in kc</th> <th style="text-align: center;">Output level in μw</th> </tr> </thead> <tbody> <tr> <td style="text-align: center;">390</td> <td style="text-align: center;">75</td> </tr> <tr> <td style="text-align: center;">420</td> <td style="text-align: center;">80</td> </tr> <tr> <td style="text-align: center;">800</td> <td style="text-align: center;">50</td> </tr> <tr> <td style="text-align: center;">900</td> <td style="text-align: center;">50</td> </tr> <tr> <td style="text-align: center;">1,700</td> <td style="text-align: center;">30</td> </tr> </tbody> </table>	Frequency in kc	Output level in μ w	390	75	420	80	800	50	900	50	1,700	30	<p>a. The TS-585A/U indication should decrease at least 6 db.</p> <p>b. Same as a above.</p>
Frequency in kc	Output level in μ w															
390	75															
420	80															
800	50															
900	50															
1,700	30															
3	AN/ARM-93 Same as step 1 above, except set GONIO DRIVE to ON and Function switch to ADF. AN/URM-25 No change from step 1. <i>Sense Antenna Adapter</i>	N/A	<p>a. Set AN/URM-25 for 70 microvolts unmodulated. Tune AN/URM-25 for zero beat in headset; then set AN/ARM-93 BFO-OFF switch to OFF. Remove headset. Set AN/URM-25 for 70 microvolts, modulated 30 percent at 400 cps. Adjust AN/ARM-93 gain control for indication of 20 milliwatts on TS-585A/U. Remove modulation and note decrease in TS-585A/U indication.</p> <p>b. Set AN/ARN-93 and AN/URM-25 to each of the</p>	<p>a. TS-585A/U indication should decrease at least 6 db.</p> <p>b. Same as a above.</p>												

	No change from step 1. <i>TS-585A/U</i> No change from step 1.		frequencies listed below, and repeat procedure <i>a</i> above. <table border="0"> <thead> <tr> <th>Frequency</th> <th>Output level</th> </tr> </thead> <tbody> <tr> <td>390</td> <td>50 μV</td> </tr> <tr> <td>420</td> <td>65 μV</td> </tr> <tr> <td>800</td> <td>50 μV</td> </tr> <tr> <td>900</td> <td>50 μV</td> </tr> <tr> <td>1,700</td> <td>25 μV</td> </tr> </tbody> </table>	Frequency	Output level	390	50 μV	420	65 μV	800	50 μV	900	50 μV	1,700	25 μV	
Frequency	Output level															
390	50 μV															
420	65 μV															
800	50 μV															
900	50 μV															
1,700	25 μV															
4	<i>AN/ARM-93</i> Same as step 1. <i>AN/URM-25</i> Same as step 1 above, except set R.F. MULTIPLIER to X100. <i>Sense Antenna Adapter</i> No change from step 1. <i>TS-585A/U</i> No change from step 1.	N/A	Set <i>AN/URM-25</i> for 1000 microvolts unmodulated. Tune <i>AN/URM-25</i> for zero beat in headset; then set <i>AN/ARM-93</i> BFO-OFF switch to OFF. <i>AN/URM-25</i> for 1000 microvolts, modulated 30 percent at 400 cps.	<i>TS-585A/U</i> should indicate 80 milliwatts, or more.												
5	<i>AN/ARM-93</i> Same as step 1 above except set GONIO DRIVE to ON and function switch to ADF. <i>AN/URM-25</i> () No change from step 1. <i>Sense antenna adapter</i> No change from step 1. <i>TS-585A/U</i> No change from step 1.	N/A	<p><i>a.</i> Disconnect the <i>TS-585A/U</i>. Set the <i>AN/URM-25</i>() for 1,000 microvolts unmodulated. Tune <i>AN/URM-25</i>() for zero beat in headset, then set BFO-OFF switch on <i>AN/ARM-93</i> to OFF. Using the loop simulator control on the <i>AN/ARM-93</i>, set the BEARING INDICATOR on N (0 degrees). Reduce the <i>AN/URM-25</i>() output until a level is reached that will cause the BEARING INDICATOR of the <i>AN/ARM-93</i> to indicate 0 ± 2 degrees over a period of 10 to 20 seconds.</p> <p><i>Note.</i> Due to noise at the low input level, the reading of the BEARING INDICATOR will be erratic. The average indication should be noted.</p> <p><i>b.</i> Set the <i>AN/ARM-93</i> and <i>AN/URM-25</i>() to each of the frequencies listed below and repeat <i>a</i> above.</p> <table border="0"> <thead> <tr> <th>Frequency in kc</th> </tr> </thead> <tbody> <tr><td>300</td></tr> <tr><td>390</td></tr> <tr><td>400</td></tr> <tr><td>600</td></tr> <tr><td>800</td></tr> <tr><td>900</td></tr> <tr><td>1,300</td></tr> <tr><td>1,700</td></tr> </tbody> </table> <p><i>c.</i> Set the <i>AN/ARM-93</i> and <i>AN/URM-25</i>() to each of the frequencies listed below and repeat <i>a</i> above.</p>	Frequency in kc	300	390	400	600	800	900	1,300	1,700	<p><i>a.</i> The <i>AN/URM-25</i>() output should not exceed 45 microvolts.</p> <p><i>b.</i> The <i>AN/URM-25</i>() output should not exceed 45 microvolts for 300 and 390 kc; 40 microvolts for 400, 600, and 800 kc; 30 microvolts for 900, 1,300 and 1,700 kc.</p> <p><i>c.</i> The <i>AN/URM-25</i>() output should not exceed 45 microvolts for 200,</p>			
Frequency in kc																
300																
390																
400																
600																
800																
900																
1,300																
1,700																

Step	Test equipment control settings	Equipment under test control settings	Test procedure	Performance standard
			<p>Set the AN/URM-25() for a 100,000-microvolts output level rather than for 1,000 microvolts as listed in <i>a</i> above.</p> <p style="text-align: center;"><i>Frequency in kc</i></p> <p style="text-align: center;">200 300 390 400 600 800 900 1,300 1,700</p> <p><i>d.</i> Set the AN/ARM-93 and AN/URM-25() to 200 kc. Set the AN/URM-25() for 45 microvolts unmodulated. Set BFO-OFF switch on the AN/ARM-93 to ON. Tune AN/URM-25() for zero beat in headset, then set BFO-OFF switch to OFF. Using the loop simulator control on the AN/ARM-93, set the BEARING INDICATOR on N (0 degrees). Using the LOOP control on the AN/ARM-93, rotate the BEARING INDICATOR needle 5 to 10 degrees in the cw direction, then in the ccw direction, from 0 degrees. Allow the BEARING INDICATOR needle to approach 0 degrees and note the difference.</p> <p><i>e.</i> If necessary, use the loop simulator control on the AN/ARM-93 to reset the BEARING INDICATOR to 0 degrees. Using the LOOP control on the AN/ARM-93, rotate the BEARING INDICATOR needle 175 to 185 degrees in the cw direction, then in the ccw direction, from 0 degrees and record the time required for the BEARING INDICATOR needle to return to 0 ± 3 degrees.</p> <p><i>f.</i> Set the AN/URM-25() for 1,000 microvolts unmodulated. Repeat <i>e</i> above.</p> <p><i>g.</i> Set the AN/ARM-93 and AN/URM-25() to each of the frequencies listed below and repeat <i>d</i>, <i>e</i>, and <i>f</i> above. Set the AN/URM-25() for a 40-microvolt output at 400, 600, and 800 kc and for a 30-microvolt output at 900, 1,300, and 1,700 kc rather than the 45 microvolts specified in <i>d</i> and <i>e</i> above.</p>	<p>300, and 390 kc; 40 microvolts for 400, 600, and 800 kc; 30 microvolts for 900, 1,300, and 1,700 kc.</p> <p><i>d.</i> The BEARING INDICATOR needle will indicate 0 ± 2 degrees. See note below.</p> <p><i>e.</i> The time required for the BEARING INDICATOR needle to return to 0 ± 3 degrees will not exceed 7 seconds. See note below.</p> <p><i>f.</i> Same as <i>e</i> above.</p> <p><i>g.</i> Same as <i>d</i>, <i>e</i>, and <i>f</i> above.</p>

Frequency in Hz
400
600
800
900
1,300

NOTE

Radio Receiver R-1391/ARN-83, CPN 522-2587-015, utilizes ADF hunt control R131 to adjust the amount of ADF needle activity. When R131 is adjusted fully clockwise, the time required to obtain a bearing is minimum, but the needle activity is maximum. When R131 is adjusted fully counterclockwise, the needle activity decreases, but the time required to obtain a bearing increases and the resolution (accuracy) of the indication may be degraded. The amount of needle activity can be set as long as the resolution and the speed required to obtain an indication are within the prescribed limits.

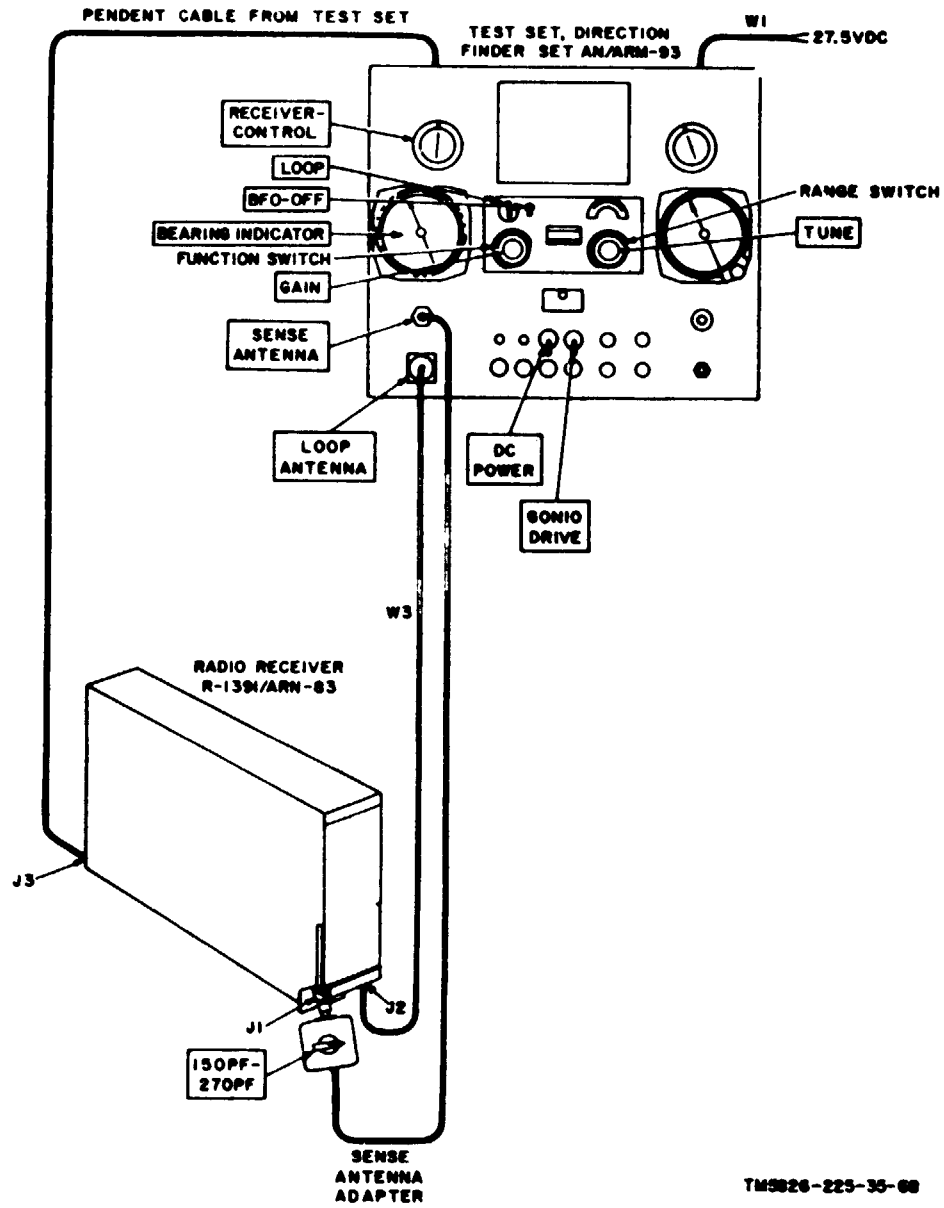

Figure 4-5. Receiver bearing indicator test.

4-11. Receiver Bearing Indicator Test

a. Test Equipment and Materials.

- (1) Test Set, Direction Finder Set AN/ARM-93.
- (2) Stopwatch.

b. Test Connections and Conditions. Connect the test equipment as shown in figure 4-5.

c. Procedure.

Step	Test equipment control settings	Equipment under test control settings	Test procedure	Performance standard
1	<p>AN/ARM-93 DC POWER: ON GONIO DRIVE: ON RECEIVER-CONTROL: RECEIVER Function switch: LOOP Range switch: 190-400 BFO-OFF: OFF GAIN: Fully cw TUNE: 200 kc on FREQUENCY indicator Sense antenna adapter 150PF-270PF: 150PF</p>	N/A	<p>a. Using the loop simulator control on the AN/ARM-93, set the BEARING INDICATOR on N (0 degrees). Set the LOOP control in the first position to the right and record the time required for the BEARING INDICATOR needle to rotate 180 degrees.</p> <p>b. Repeat a above, except set the LOOP control to the first position to the left.</p> <p>c. Repeat a above, except set the LOOP control to the second position to the right.</p> <p>d. Repeat a above, except set the LOOP control to the second position to the left.</p>	<p>a. The time required for the BEARING INDICATOR needle to rotate 180 degrees will be 30±15 seconds.</p> <p>b. Same as a above.</p> <p>c. The time required for the BEARING INDICATOR needle to rotate 180 degrees will not exceed 7 seconds.</p> <p>d. Same as c above.</p>
2	<p>AN/ARM-93 DC POWER: ON GONIO DRIVE: ON RECEIVER-CONTROL: RECEIVER Function switch: LOOP Range switch: 190-400 BFO-OFF: OFF GAIN: Fully cw TUNE: 300kc on FREQUENCY indicator Sense antenna adapter 150PF-270PF: 150PF</p>	N/A	<p>Using the LOOP control on the AN/ARM-93, set the BEARING INDICATOR needle on N (0 degrees). Change the function switch to ADF. Record the time required for the BEARING INDICATOR needle to rotate 360 degrees with no signal input.</p> <p><i>Note.</i> Due to noise, the movement of the BEARING INDICATOR needle will be erratic. However, an average of these fluctuations will cause needle rotation.</p>	<p>The BEARING INDICATOR needle will not exceed 720 degrees in 2 minutes.</p>

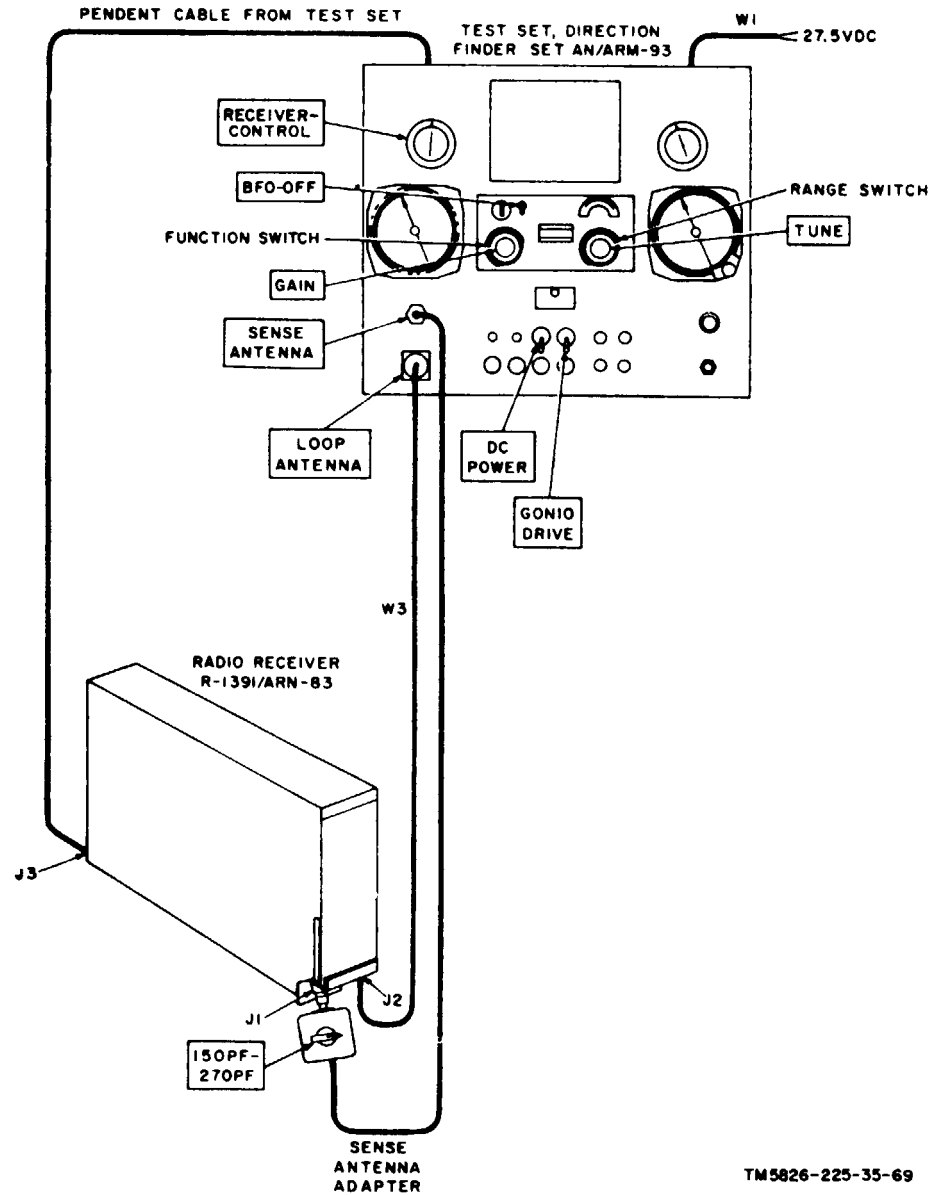

Figure 4-6. Receiver tuning and switching time test.

4-12. Receiver Tuning and Switching Time Test

a. Test Equipment and Materials.

- (1) Test Set, Direction Finder Set AN/ARM-93.
- (2) Stopwatch.

b. Test Connections and Conditions. Connect the test equipment as shown in figure 4-6.

c. Procedure.

Step	Test equipment control settings	Equipment under test control settings	Test procedure	Performance standard
1	AN/ARM-93: DC POWER: ON GONIO DRIVE: OFF RECEIVER-CONTROL: RECEIVER Function switch: ANT Range switch: 400-850 BFO-OFF: OFF GAIN: Any position TUNE: 800 kc on FREQUENCY indicator Sense antenna adapter 150PF-270PF: 150PF	N/A	On the AN/ARM-93, set DC POWER to OFF, function switch to ADF, range switch to 190-400, and TUNE to 200 kc on FREQUENCY indicator. Set the DC POWER to ON and record the time required for the receiver to switch to the new function and tune to the new frequency (observe the left side of the receiver).	The time will not exceed 6 seconds.

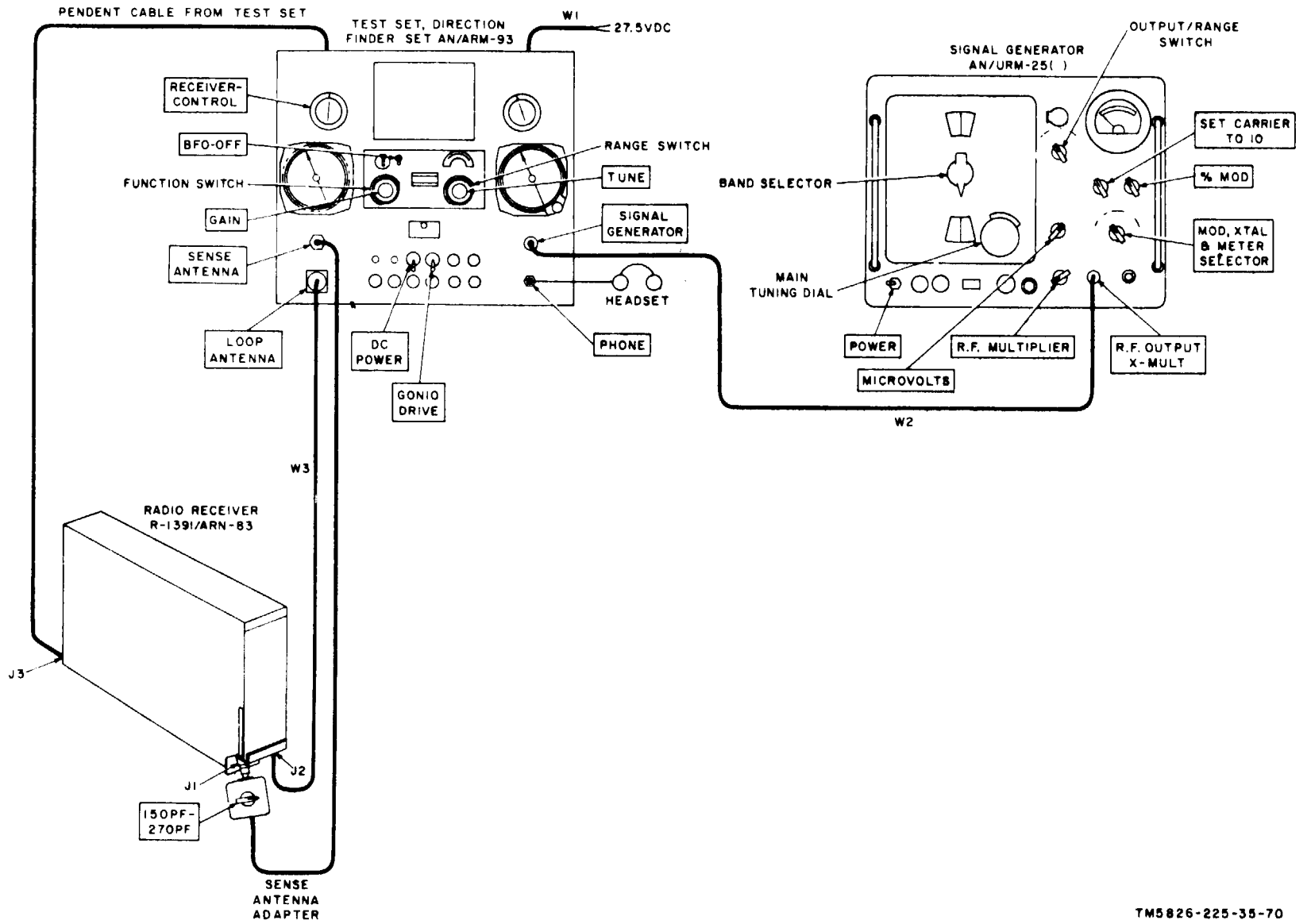

Figure 4-7. Receiver muting test.

4-13. Receiver Muting Test

a. Test Equipment and Materials.

- (1) Test Set, Direction Finder Set AN/ARM-93.
- (2) Signal Generator AN/URM-25().
- (3) Headset.

b. Test Connections and Conditions. Connect the test equipment as shown in figure 4-7. Turn on the equipment and allow a 5-minute warmup before proceeding.

c. Procedure.

Step	Test equipment control settings	Equipment under test control settings	Test procedure	Performance standard
1	AN/ARM-93 DC POWER: ON GONIO DRIVE: OFF RECEIVER-CONTROL: RECEIVER Function switch: ANT Range switch: 190-400 BFO-OFF: OFF GAIN: Fully cw TUNE: 200 kc on FREQUENCY indicator AN/URM-25() POWER: ON Band selector: 95-300KC Main tuning dial: 200 kc on KILO-CYCLES indicator Output/range switch: X-MULT in 10KC-300KC range. TO 10: Fully cw MICROVOLTS: Fully cw MOD, XTAL & METER SELECTOR: CW R.F. MULTIPLIER: X1K Sense antenna adapter 150PF-270PF: 150PF SET CARRIER	N/A	<p><i>a.</i> Set the AN/URM-25() for 1,000 microvolts, modulated 30 percent at 400 cps. While listening with the headset, set the function switch on the AN/ARM-93 to LOOP, then back to ANT.</p> <p><i>b.</i> While listening with the headset, set the function switch on the AN/ARM-93 to ADF, then back to ANT.</p>	<p><i>a.</i> The audio output in the headset will be muted and no undesirable clicks or transient noises will occur.</p> <p><i>b.</i> Same as <i>a</i> above.</p>

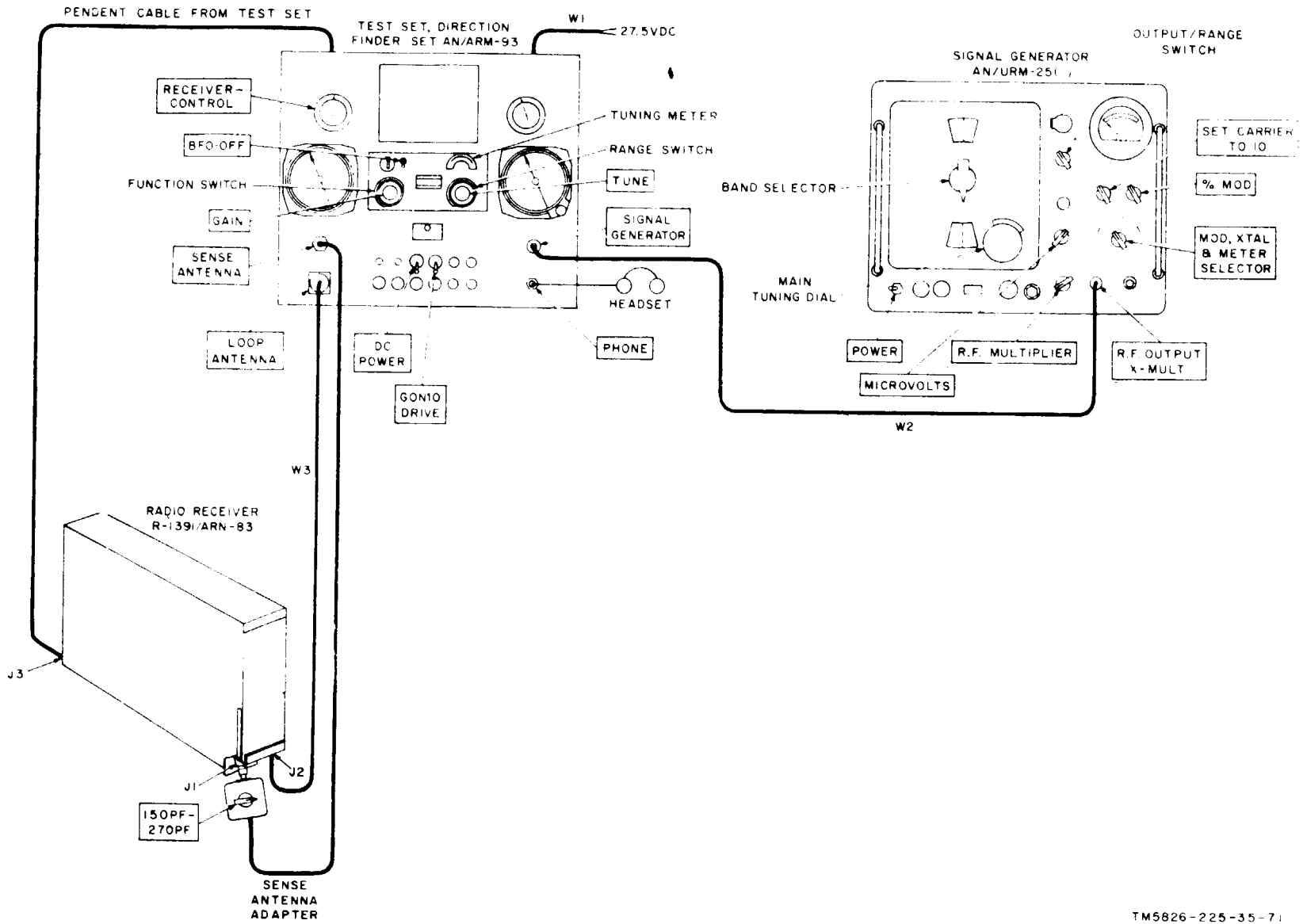

4-14. Receiver Tuning Meter Test

a. *Test Equipment and Materials.*

- (1) Test Set, Direction Finder Set AN/ARM-93.
- (2) Signal Generator AN/URM-25().
- (3) Headset.

b. *Test Connections and Conditions.* Connect the test equipment as shown in figure 4-8. Turn on the equipment and allow a 5-minute warmup before proceeding.

c. *Procedure.*

Step	Test equipment control settings	Equipment under test control settings	Test procedure	Performance standard
1	<p>AN/ARM-93 DC POWER: ON GONIO DRIVE: OFF RECEIVER-CONTROL: RECEIVER Function switch: ANT Range switch: 190-400 BFO-OFF: BFO GAIN: Fully cw TUNE: 200 kc on FREQUENCY indicator AN/URM-25() POWER: ON Band selector: 95-300KC Main tuning dial: 200 kc on KILOCYCLES indicator Output/range switch: X-MULT in 10KC-300KC range SET CARRIER TO 10: Fully cw MICROVOLTS: Fully cw MOD, XTAL & METER SELECTOR: CW R.F. MULTIPLIER: X10K Sense antenna adapter 150PF-270PF: 150PF</p>	N/A	<p>Set the AN/URM-25() for 50,000 microvolts, modulated 30 percent at 400 cps. Tune AN/URM-25() for zero beat in headset and read the AN/ARM-93 tuning meter in percent of full-scale indication. <i>Note.</i> Each mark on the tuning meter represents 20 percent.</p>	Tuning meter indication will be 45 to 80 percent of full scale.

Change 3 4-21
 / (4-22 blank)

4-15. Inverter, Power Static CV-2128/ARN-83 Physical Tests and Inspection

a. Test Equipment and Materials. None required.

b. Test Connections and Conditions. Remove the cover from the inverter.

c. Procedure.

Step	Test equipment control settings	Equipment and materials	Test procedure	Performance standard
1	N/A	N/A	<ol style="list-style-type: none"> a. Inspect for loose or missing screws, bolts, or nuts. b. Inspect insulation of wiring for cuts, pinches, and signs of burning. c. Check that nuts on top of transistors are tight and none missing. d. Inspect mica insulating washers between transistors and chassis for cracks. e. Check resistors for cracks and signs of burning. f. Inspect all insulated terminal studs for looseness and signs of damage. g. Inspect connector for bent pins and cracked insulation material. h. Inspect soldered connections for cold-soldered connections. 	<ol style="list-style-type: none"> a. Screws, bolts, and nuts will be tight; none missing. b. No cuts, pinches, or signs of burning evident. c. Nuts will be tight; none missing. d. No cracks evident. e. No signs of cracks or burning evident. f. No looseness or damage evident. g. No bent pins or cracked insulation evident. h. No cold-soldered connections evident.
2	N/A		Check inverter for applicable modification work orders (see para 4.4)	None.

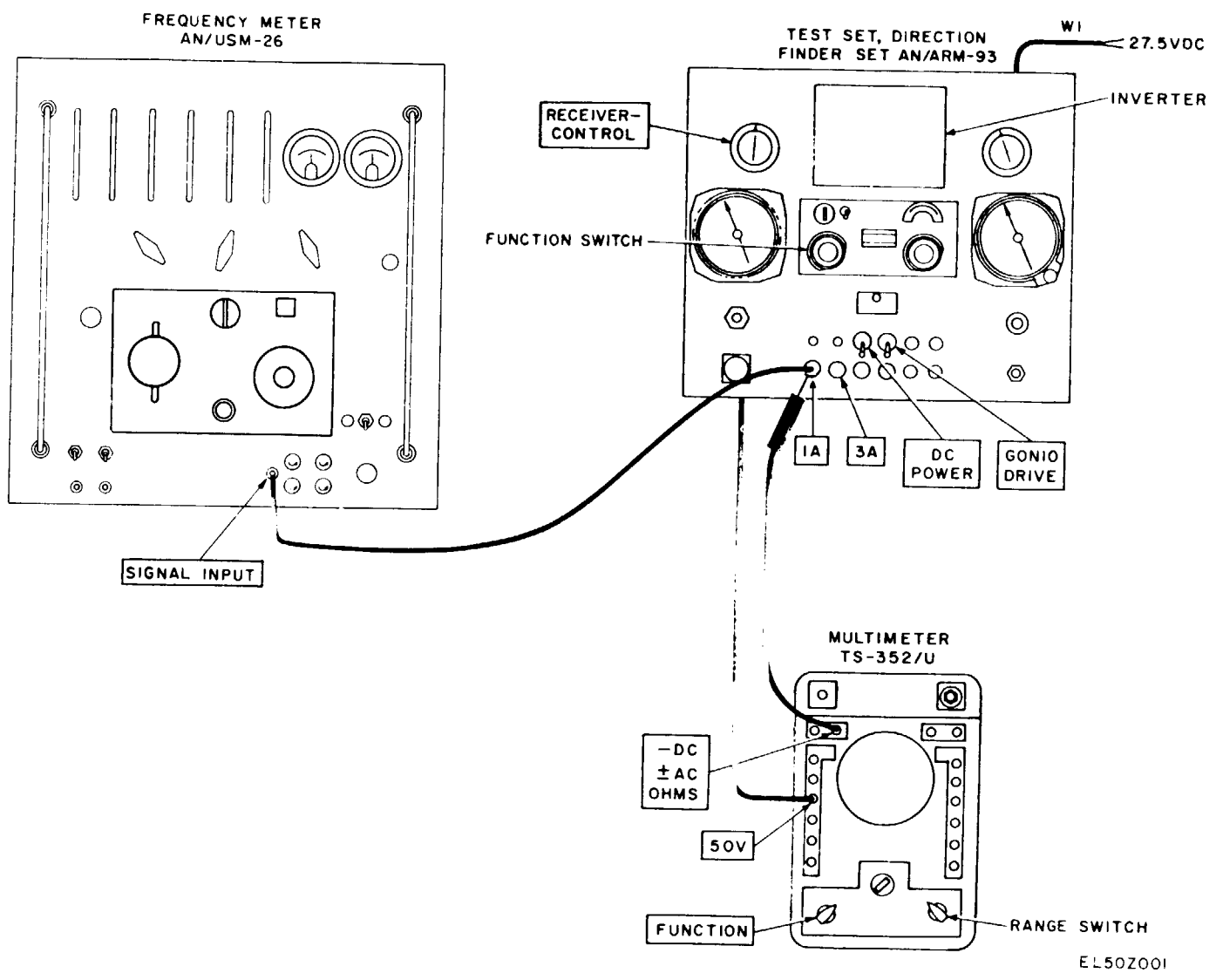

Figure 4-9. Inverter test.

4-16. Inverter Test

a. Test Equipment and Materials.

- (1) Test Set, Direction Finder Set AN/ARM-93.
- (2) Multimeter TS-352/U.
- (3) Frequency Meter, AN/USM-26.

b. Test Connections and Conditions. Connect the test equipment as shown in figure 4-9. The inverter can be inserted directly into the AN/ARM-93 or connected by means of cable W4 (part of AN/ARM-93).

c. Procedure.

Step	Test equipment control settings	Equipment under test control settings	Test procedure	Performance standard
1	<p><i>AN/ARM-93</i></p> <p>DC POWER: ON RECEIVER-CONTROL: CONTROL</p> <p>Function switch: ON</p> <p><i>TS-352/U</i> FUNCTION: DIRECT AN/USM-26 POWER: ON INT-EXT: 100kc Standard FUNCTION SELECTOR: Frequency FREQUENCY UNIT: 1 DISPLAY TIME: As desired</p>	N/A	<p><i>a.</i> Insert the probe of the TS-352/U into the center of the 3A fuse cap.</p> <p><i>b.</i> Set the FUNCTION switch on the TS-352/U to AC VOLTS. Insert the probe of the TS-352/U into the center of the 1A fuse cap.</p> <p><i>c.</i> Connect the input of the AN/USM-26 to the center of 1A fuse cap.</p>	<p><i>a.</i> The voltage should be $+27.5 \pm 2.2$ volts dc.</p> <p><i>b.</i> The voltage should be 26 ± 2 volts ac.</p> <p><i>c.</i> The Static Power Inverter output frequency shall be $400 \text{ Hz} \pm 10\%$.</p>

4-17. Antenna AS-1863/ARN-83 Physical Tests and Inspection

a. Test Equipment and Materials. None required.

b. Test Connections and Conditions. None required.

c. Procedure.

Step	Test equipment control settings	Equipment under test control settings	Test procedure	Performance standard
1	N/A	N/A	<p><i>a.</i> Inspect connector for bent pins and cracked insulation material.</p> <p><i>b.</i> Inspect surfaces for large dents, cracks, or punctures.</p>	<p><i>a.</i> No bent pins or cracked insulation evident.</p> <p><i>b.</i> No large dents, cracks, or punctures evident.</p>

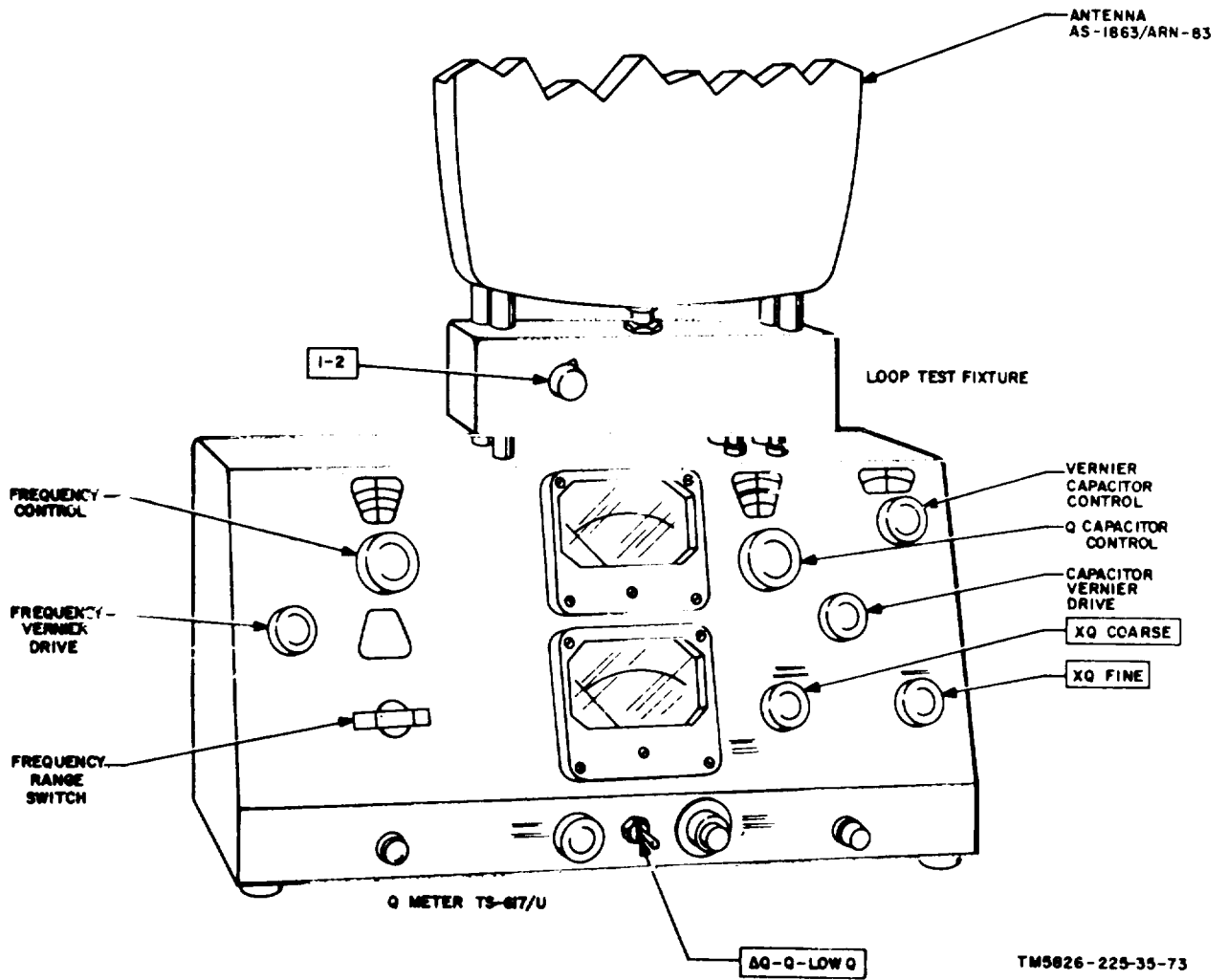

Figure 4-10. Loop antenna test.

4-18. Loop Antenna Test

a. Test Equipment and Materials.

- (1) Loop test fixture of Test Set, Direction Finder Set AN/ARM-93.
- (2) Q Meter TS-617/U.

b. Test Connections and Conditions. Connect the test equipment as shown in figure 4-10.

c. Procedure.

Step	Test equipment control settings	Equipment under test control settings	Test procedure	Performance standard
1	<p><i>Loop test fixture</i> 1-2: 1 TS-617/U XQ COARSE: Away from POWER/OFF position. Frequency range switch: 700-1700 scale on the KILOCYCLES frequency dial. Frequency control: 1,000 kc on the KILOCYCLES frequency dial. ΔQ-Q-LOW Q: Q</p>	N/A	<p>a. Set the Q meter to 1.0 mc and adjust the capacity reading for maximum Q. b. Set loop test fixture 1-2 control to 2 and repeat a above.</p>	<p>a. Capacity reading on MMFD dial should be 210 ±70 picofarad. b. Same as a above.</p>

4-19. Summary of Test Data

Personnel may find it convenient to arrange a checklist in a manner similar to that shown below:

<p>1 CONTROL UNIT</p> <p>CONTROL TEST to 1</p> <p>LOOP switch to center position 0 ohms</p> <p>LOOP switch second position left or right 0 ohms</p> <p>LOOP switch first position left or right 4,700 ±470 ohms</p> <p>CONTROL TEST to 2</p> <p>BFO-OFF to BFO 0 ohms</p> <p>BFO-OFF to OFF Infinity ohms</p> <p>CONTROL TEST to 3</p> <p>Function switch to ADF 0 ohms</p> <p>Function switch to ANT 0 to 5,000 ±500 ohms</p> <p>Function switch to LOOP 470 ±47 to 5,470 ±550 ohms</p> <p>CONTROL TEST to 4</p> <p>Function switch to ADF 5,000 ±500 ohms</p> <p>Function switch to ANT 5,000 ±500 ohms</p> <p>Function switch to LOOP 5,470 ±550 ohms</p> <p>CONTROL TEST to 5</p> <p>Function switch to ANT 0 ohms</p> <p>Function switch to LOOP 0 ohms</p> <p>Function switch to ADF 0 to 1400 ±140 ohms</p> <p>CONTROL TEST to 6</p> <p>Function switch to ADF Approximately 650 ohms</p> <p>Function switch to ANT Infinity ohms</p> <p>Function switch to LOOP Infinity ohms</p> <p>CONTROL TEST to 7</p> <p>Function switch to ADF 0 ohms</p> <p>Function switch to ANT 0 ohms</p> <p>Function switch to LOOP 0 ohms</p> <p>CONTROL TEST to 8</p> <p>Function switch to ADF Infinity ohms</p> <p>Function switch to ANT 0 ohms</p> <p>Function switch to LOOP 0 ohms</p> <p>CONTROL TEST to 9</p> <p>Function switch to ANT Infinity ohms</p> <p>Function switch to ADF 0 ohms</p> <p>Function switch to LOOP 0 ohms</p> <p>CONTROL TEST to 10</p> <p>Function switch to LOOP Infinity ohms</p> <p>Function switch to ADF 0 ohms</p> <p>Function switch to ANT 0 ohms</p> <p>CONTROL TEST to 11</p> <p>Range switch to 190-400 25 ±2 ohms</p> <p>Range switch to 400-850 0 ohms</p> <p>Range switch to 850-1750 0 ohms</p>	<p>CONTROL TEST to 12</p> <p>Range switch to 400-850 25 ±2 ohms</p> <p>Range switch to 190-400 0 ohms</p> <p>Range switch to 850-1750 0 ohms</p> <p>CONTROL TEST to 13</p> <p>Range switch to 850-1750 25 ±2 ohms</p> <p>Range switch to 190-400 0 ohms</p> <p>Range switch to 400-850 0 ohms</p>	<p>2 RECEIVER FREQUENCY ACCURACY</p> <p>200 kc 200 ±2.0 kc</p> <p>600 kc 600 ±5 kc</p> <p>1,000 kc 1,000 ±10kc</p> <p>3 RECEIVER BANDWIDTH</p> <p>200 uv (6 db) and 1,300 kc NLT 2.8 kc</p> <p>100,000 uv (60 db) and 1,300 kc NMT 11.0 kc</p> <p>200 uv (6 db) and 200 kc NLT 2.3 kc</p> <p>100,000 uv (60 db) and 200 kc NMT 10.0 kc</p> <p>4 RECEIVER SENSITIVITY</p> <p>Antenna function, 6 db</p> <p>200 kc 50 uv</p> <p>390 kc 25 uv</p> <p>420 kc 35 uv</p> <p>800 kc 20 uv</p> <p>900 kc 25 uv</p> <p>1,700 kc 22 uv</p> <p>Loop function, 125 uv, 6db 125 uv</p> <p>200 kc 85 uv</p> <p>390 kc 85 uv</p> <p>420 kc 60 uv</p> <p>800 kc 50 uv</p> <p>900 kc 40 uv</p> <p>1,700 kc</p> <p>Bearing threshold, 1,000 uv</p> <p>200 kc NMT 45 uv</p> <p>300 kc NMT 45 uv</p> <p>390 kc NMT 45 uv</p> <p>400 kc NMT 40 uv</p> <p>600 kc NMT 40 uv</p> <p>800 kc NMT 40 uv</p> <p>900 kc NMT 30 uv</p> <p>1,300 kc NMT 30 uv</p> <p>1,700 kc NMT 30 uv</p> <p>Bearing threshold, 100,000 uv</p> <p>200 kc NMT 45 uv</p> <p>300 kc NMT 45 uv</p> <p>390 kc NMT 45 uv</p> <p>400 kc NMT 30 uv</p> <p>600 kc NMT 30 uv</p> <p>800 kc NMT 30 uv</p> <p>Bearing accuracy 0 ±2 degrees</p> <p>Bearing speed</p> <p>45 uv, 200 kc NMT 7 sec.</p> <p>1,000 uv, 200 kc NMT 7 sec.</p> <p>40 uv</p> <p>400 kc NMT 7 sec.</p> <p>600 kc NMT 7 sec.</p> <p>800 kc NMT 7 sec.</p>
--	---	--

	30 uv 900 kc 1,300 kc 1,700 kc	NMT 7 sec. NMT 7 sec. NMT 7 sec.
5	BEARING INDICATOR Speed of rotation (180°) LOOP control first position to right LOOP control first position to left LOOP control second position to right LOOP control second position to left Rotational indicator with no signal input.	30 ± 15 sec. 30 ± 15 sec. NMT 7 sec. NMT 7 sec. Not to exceed 720° in 2 min

6	TUNING AND SWITCHING TIME ANT and 800 kc to ADF and 200 kc	NMT 6 sec.
7	MUTING Audio out during function switching	None.
8	TUNING METER ANT function, 50,000 uv. 200 kc	60 ± 10 percent
9	INVERTER Dc voltage Ac voltage	27.5 ± 0.5 volts dc 26 ± 2.0 volts ac
10	LOOP ANTENNA Loop 1 Loop 2	210 ± 70 pf 210 ± 70 pf

Section II. DEPOT INSPECTION STANDARDS

4-20. Applicability of Depot inspection Standards

a. The tests outlined in this section are designed to measure the performance capability of a repaired equipment. Equipment that is to be returned to stock should meet the standards given in these tests.

b. Applicable procedures of the Army depots performing these tests and the general standards for repaired electronic equipment given in TB SIG 355-1, TB SIG 35S-2, and TB SIG 355-3 form a part of the requirements for testing this equipment.

4-21. Test Procedures

a. The test equipment and power required for depot inspection standards are the same as indicated in paragraph 4-2.

b. The operational test for depot inspection standards are the same as the tests given in

paragraphs 4-8 through 4-18. Perform the tests in the order in which they are given, and observe that the results meet the minimum standard indicated in each test,

Tests	Paragraph
Control Unit test -----	4-6
Radio Receiver R-1391/ARN-83 physical tests and inspection.	4-7
Receiver frequency accuracy test -----	4-8
Receiver bandwidth test -----	4-9
Receiver sensitivity test -----	4-10
Receiver bearing indicator test -----	4-11
Receiver tuning and switching time test --	4-12
Receiver muting test -----	4-13
Receiver tuning meter test -----	4-14
Inverter, Power Static CV-2128/ARN-83 physical tests and inspection.	4-15
Inverter test -----	4-16
Antenna AS-1868/ARN-83 physical test and inspection -----	4-17
Loop antenna test -----	4-18

COLOR CODE MARKING FOR MILITARY STANDARD RESISTORS

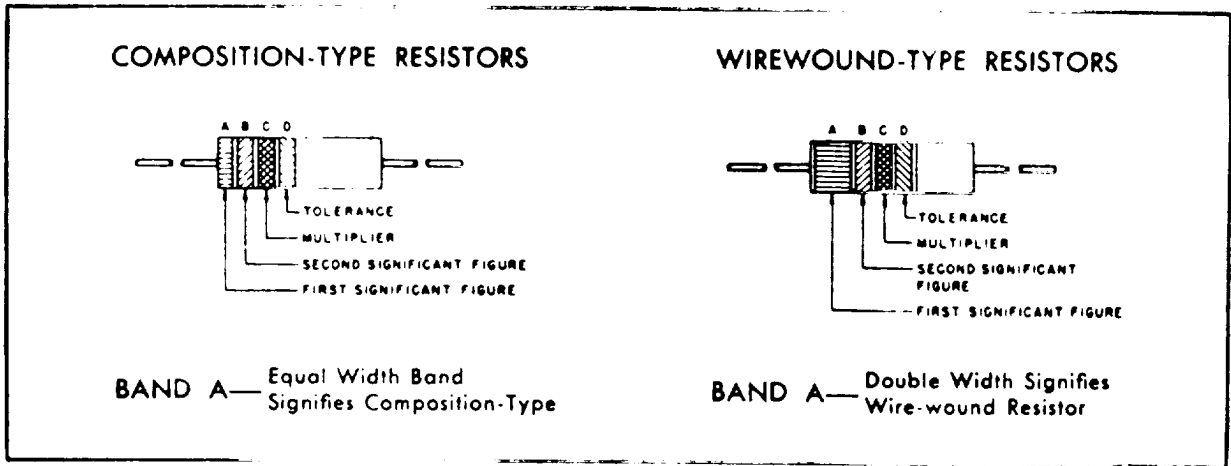

COLOR CODE TABLE

BAND A		BAND B		BAND C		BAND D*	
COLOR	FIRST SIGNIFICANT FIGURE	COLOR	SECOND SIGNIFICANT FIGURE	COLOR	MULTIPLIER	COLOR	RESISTANCE TOLERANCE (PERCENT)
BLACK	0	BLACK	0	BLACK	1		
BROWN	1	BROWN	1	BROWN	10		
RED	2	RED	2	RED	100		
ORANGE	3	ORANGE	3	ORANGE	1,000		
YELLOW	4	YELLOW	4	YELLOW	10,000	SILVER	± 10
GREEN	5	GREEN	5	GREEN	100,000	GOLD	± 5
BLUE	6	BLUE	6	BLUE	1,000,000		
PURPLE (VIOLET)	7	PURPLE (VIOLET)	7				
GRAY	8	GRAY	8	SILVER	0.01		
WHITE	9	WHITE	9	GOLD	0.1		

EXAMPLES OF COLOR CODING

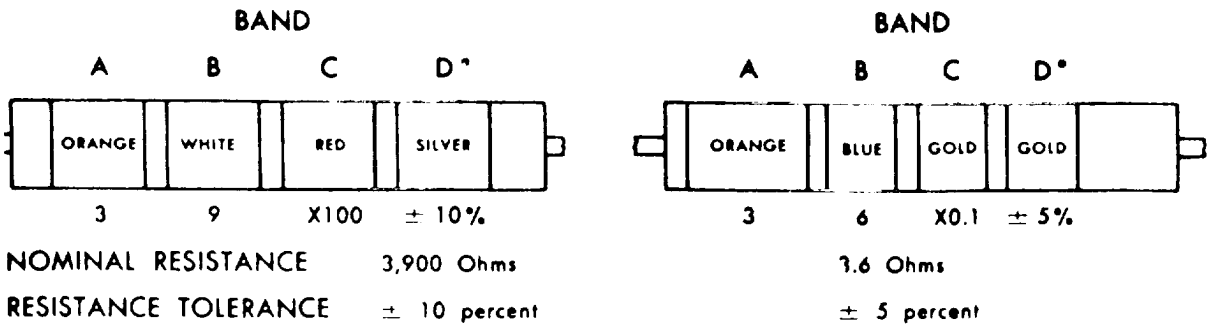

*If Band D is omitted, the resistor tolerance is ± 20%, and the resistor is not Mil-Std.

Figure 4-11. Color code markings for MIL-STD resistors.

STD-R2

CHAPTER 5

ILLUSTRATIONS

This chapter contains illustrations which have been initially referenced in chapters 1, 2, and 3.

NOTE

Revision history for the various units is shown in the notes column on the applicable schematic diagrams. Effectivities are identified by the following methods: MCN (manufacturer control number), starts with 3-digit number (101) and up; CI (configuration identifier), a 5-digit number; or REV LTR (revision letter), where a dash (-) denotes the original, the letter A represents the first change, the letter B represents the second change, etc. One of the above methods may be used to denote revision effectivities.

COLOR CODE MARKING FOR MILITARY STANDARD CAPACITORS

GROUP I Capacitors, Fixed, Various-Dielectric, Styles CM, CN, CY, and CB

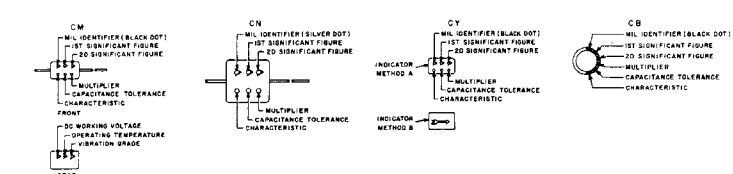

GROUP II Capacitors, Fixed Ceramic Dielectric (General Purpose) Style CK

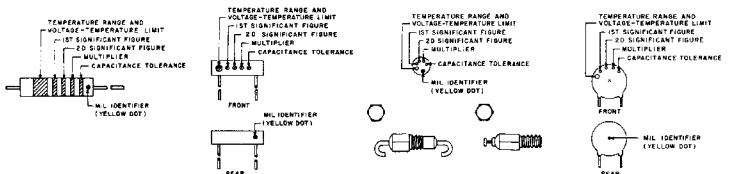

GROUP III Capacitors, Fixed, Ceramic Dielectric (Temperature Compensating) Style CC

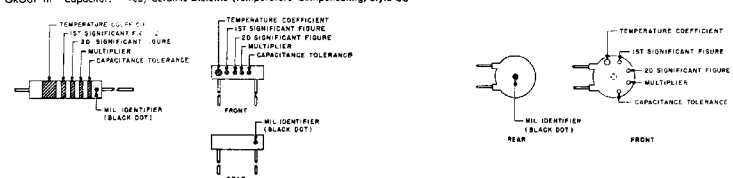

COLOR CODE TABLES

TABLE I - For use with Group I, Styles CM, CN, CY and CB

COLOR	MIL ID	1st SIG FIG	2nd SIG FIG	MULTIPLIER	CAPACITANCE TOLERANCE				CHARACTERISTIC	DC WORKING VOLTAGE		OPERATING TEMP RANGE	VIBRATION GRADE
					CM	CN	CY	CB		CM	CN		
BLACK	CM, CN, CY, CB	0	0	1			± 35%	± 35%	A			-55° to +75°C	10-25 (M)
BROWN		1	1	10			± 2%	± 2%	B			-55° to +75°C	10-25 (M)
RED		2	2	100			± 2%	± 2%	C			-55° to +75°C	10-25 (M)
ORANGE		3	3	1,000			± 35%		D	3	300	-55° to +125°C	10-25 (M)
YELLOW		4	4	10,000					E			-55° to +125°C	10-25 (M)
GREEN		5	5				± 5%		F		300	-55° to +125°C	10-25 (M)
BLUE		6	6						G			-55° to +125°C	10-25 (M)
PURPLE		7	7						H			-55° to +125°C	10-25 (M)
WHITE		8	8						I			-55° to +125°C	10-25 (M)
GRAY		9	9						J			-55° to +125°C	10-25 (M)
GOLD				0.1			± 5%	± 5%	K			-55° to +125°C	10-25 (M)
SILVER				0.01			± 10%	± 10%	L			-55° to +125°C	10-25 (M)

TABLE II - For use with Group II, General Purpose, Style CK

COLOR	TEMP RANGE AND VOLTAGE LIMIT	1st SIG FIG	2nd SIG FIG	MULTIPLIER	CAPACITANCE TOLERANCE	MIL ID
BLACK		0	0	1	± 35%	
BROWN		1	1	10	± 35%	
RED		2	2	100	± 35%	
ORANGE		3	3	1,000		
YELLOW		4	4	10,000		
GREEN		5	5			
BLUE		6	6			
PURPLE		7	7			
WHITE		8	8			
GRAY		9	9			
GOLD				0.1		
SILVER				0.01		

TABLE III - For use with Group III, Temperature Compensating, Style CC

COLOR	TEMPERATURE COEFFICIENT	1st SIG FIG	2nd SIG FIG	MULTIPLIER	CAPACITANCE TOLERANCE	MIL ID
BLACK	0	0	0	1	± 35%	
BROWN	-20	1	1	10	± 35%	
RED	-30	2	2	100	± 35%	
ORANGE	-40	3	3	1,000		
YELLOW	-50	4	4	10,000		
GREEN	-60	5	5			
BLUE	-70	6	6			
PURPLE	-80	7	7			
WHITE	-90	8	8			
GRAY	-100	9	9			
GOLD				0.1		
SILVER				0.01		

1. The multiplier is the number by which the two significant (SIG) figures are multiplied to obtain the capacitance in p.f.
 2. Letters indicate the Characteristics designated in applicable specifications: MIL-C-81, MIL-C-91, MIL-C-1272, and MIL-C-10950 respectively.
 3. Letters indicate the temperature range and voltage-temperature limits designated in MIL-C-11015.
 4. Temperature coefficient in parts per million per degree centigrade.

Figure 8-1. Color code marking for MIL-STD capacitors.

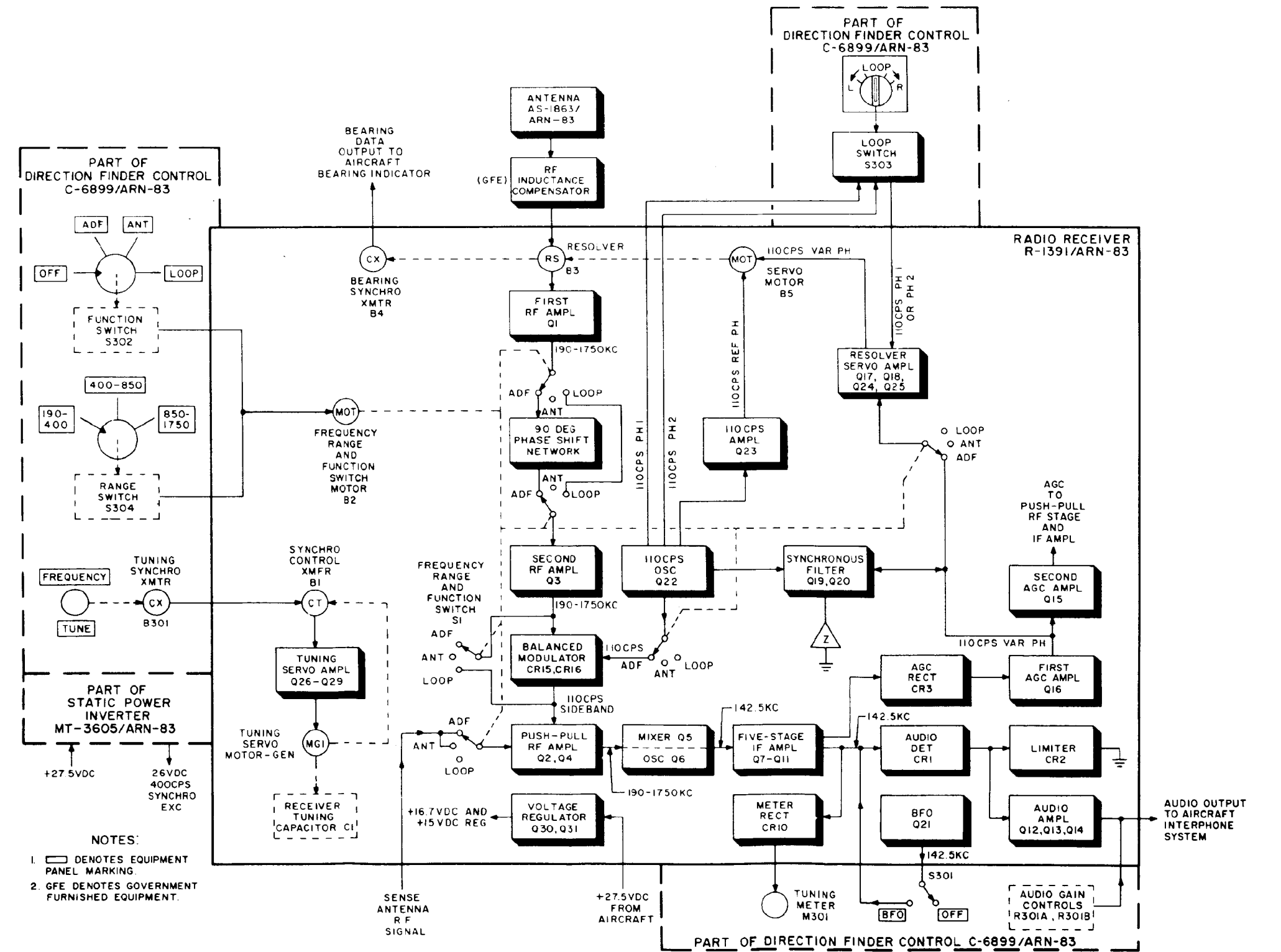

Figure 5-2. Direction Finder Set AN/ARN-83, overall functional block diagram.

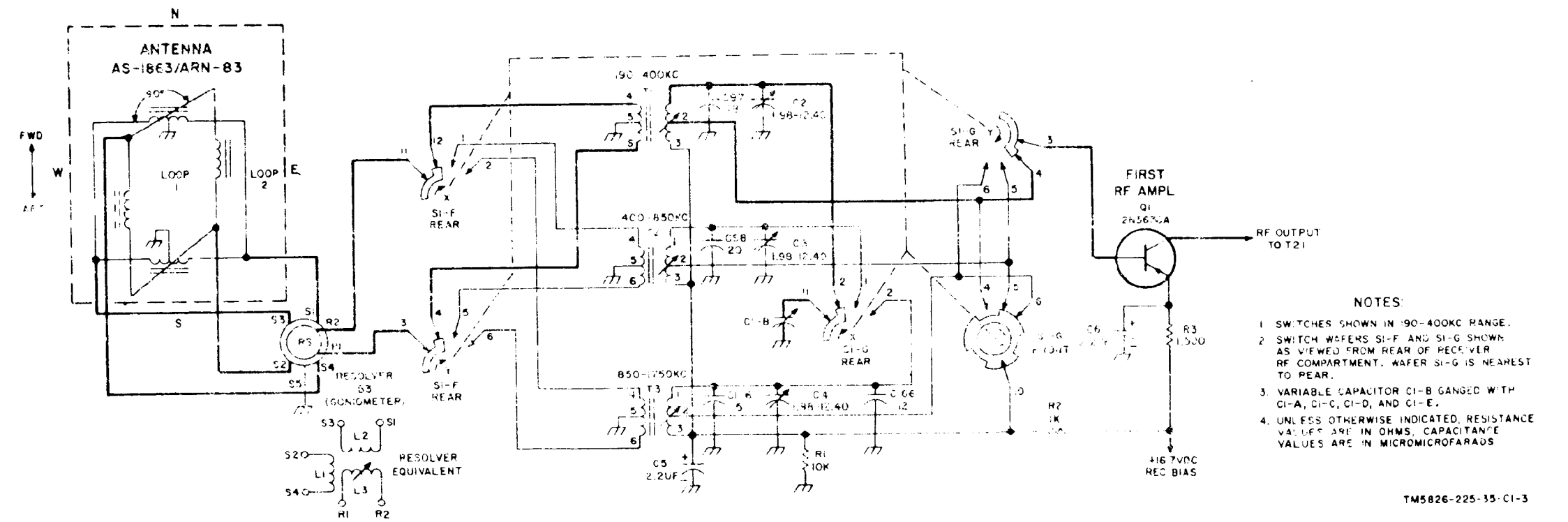
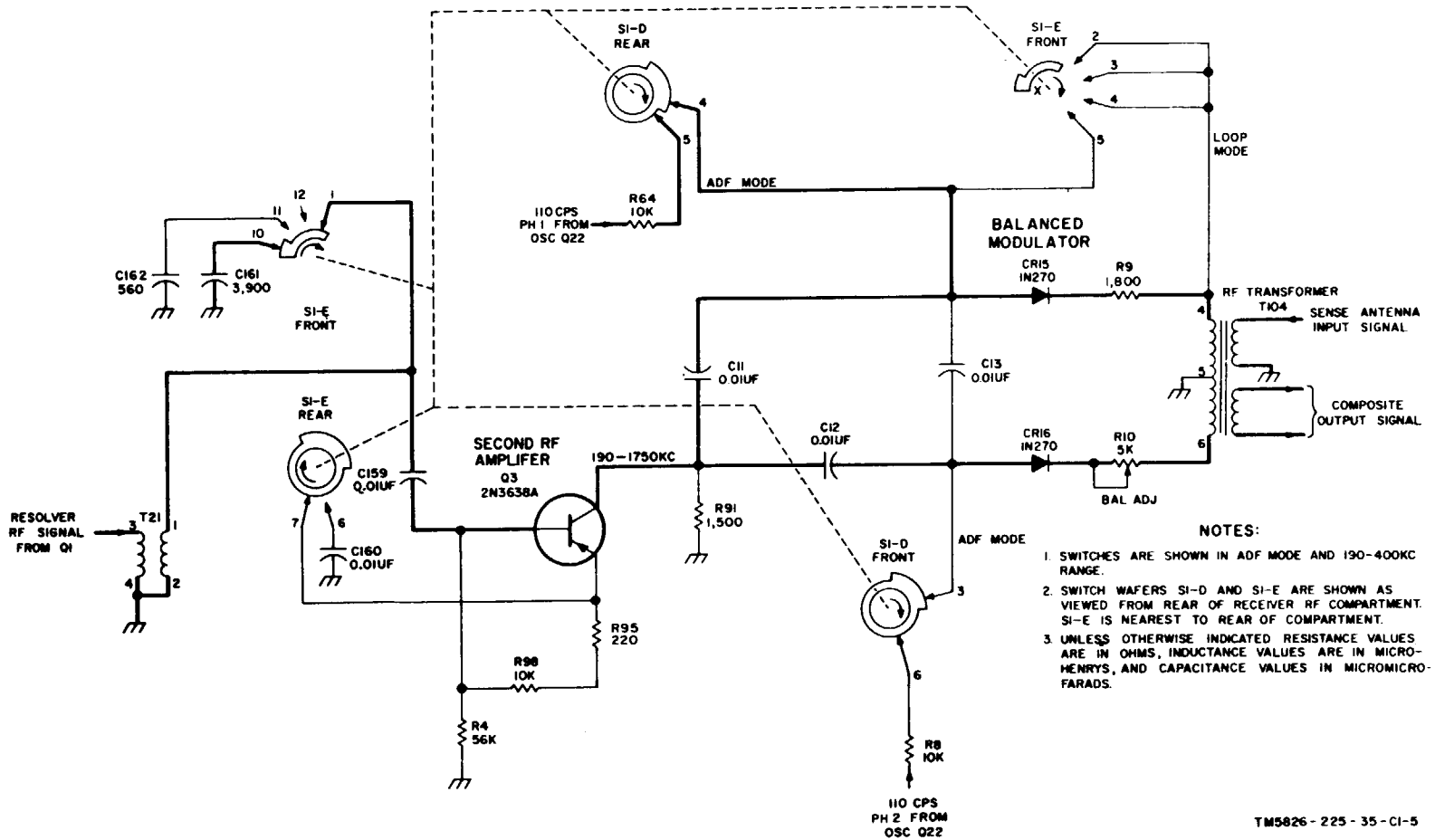

Figure 5-3. Loop antenna resolver, and first RF amplifier, schematic diagram



- NOTES:
1. SWITCHES ARE SHOWN IN ADF MODE AND 190-400KC RANGE.
 2. SWITCH WAFERS SI-D AND SI-E ARE SHOWN AS VIEWED FROM REAR OF RECEIVER RF COMPARTMENT. SI-E IS NEAREST TO REAR OF COMPARTMENT.
 3. UNLESS OTHERWISE INDICATED RESISTANCE VALUES ARE IN OHMS, INDUCTANCE VALUES ARE IN MICROHENRYS, AND CAPACITANCE VALUES IN MICROMICROFARADS.

Figure 5-4. Phase-shift network, second RF amplifier, and balanced modulator, schematic diagram.

TM5826-225-35-CI-5

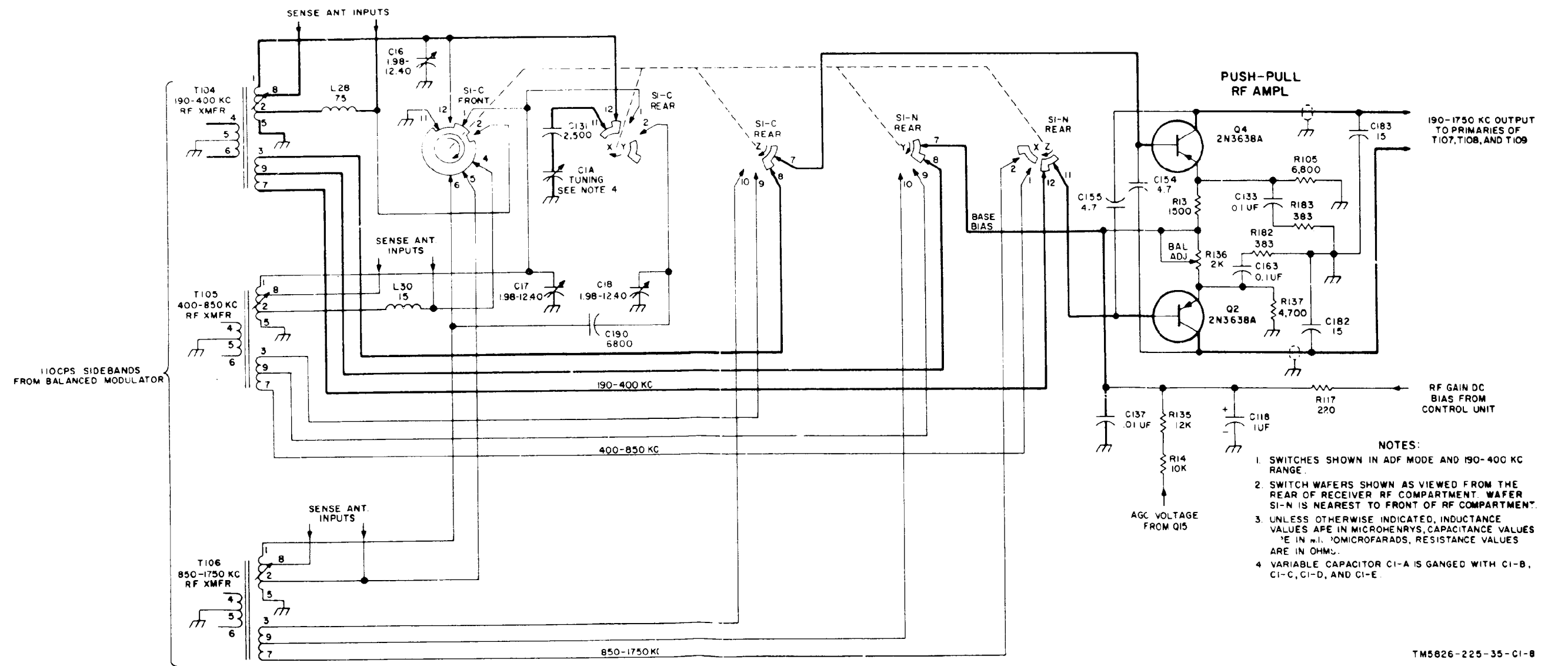
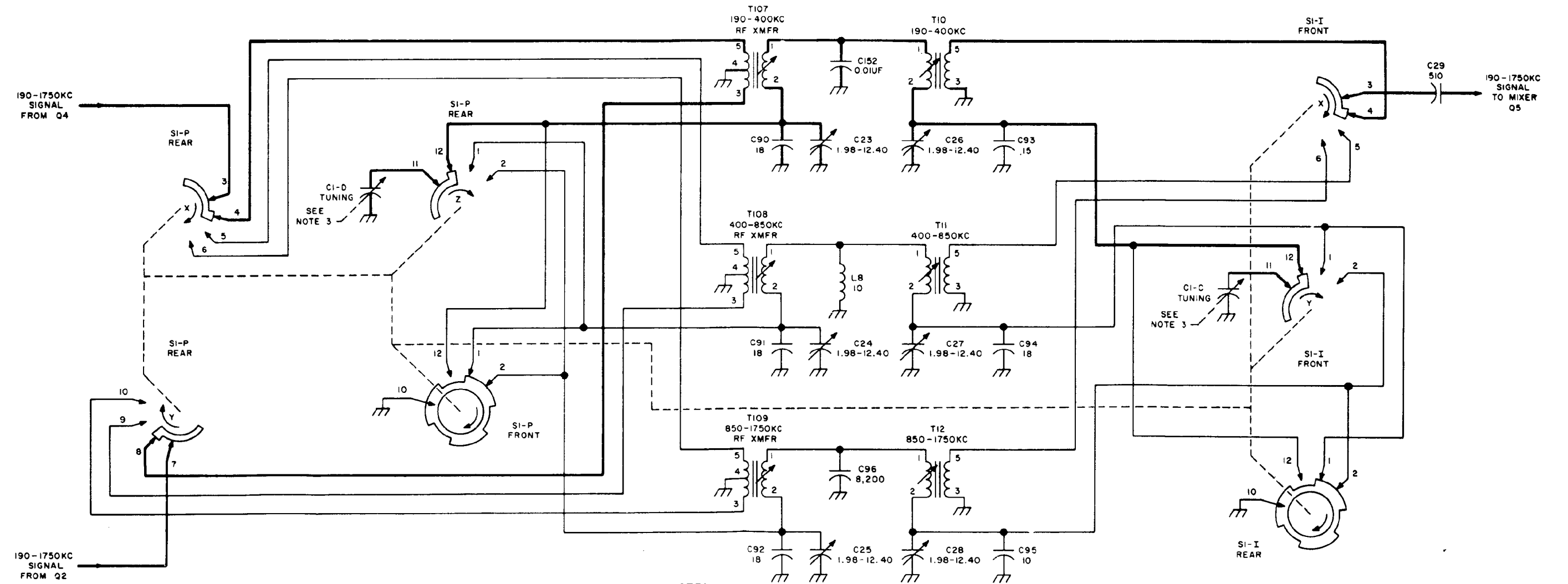

Figure 5-5. Push-pull RF amplifier, schematic diagram.



NOTES

1. SWITCH WAFERS SHOWN AS VIEWED FROM THE REAR OF RECEIVER RF COMPARTMENT. WAFER SI-I IS NEAREST TO REAR OF RECEIVER.
2. UNLESS OTHERWISE INDICATED, INDUCTANCE VALUES ARE IN MICROHENRIES, CAPACITANCE VALUES ARE IN MICROMICROFARADS.
3. VARIABLE CAPACITORS CI-C AND CI-D ARE GANGED WITH CI-A, CI-B, AND CI-E.

Figure 5-6. Mixer coupling networks, schematic diagram.

TM5826-225-35-CI-9

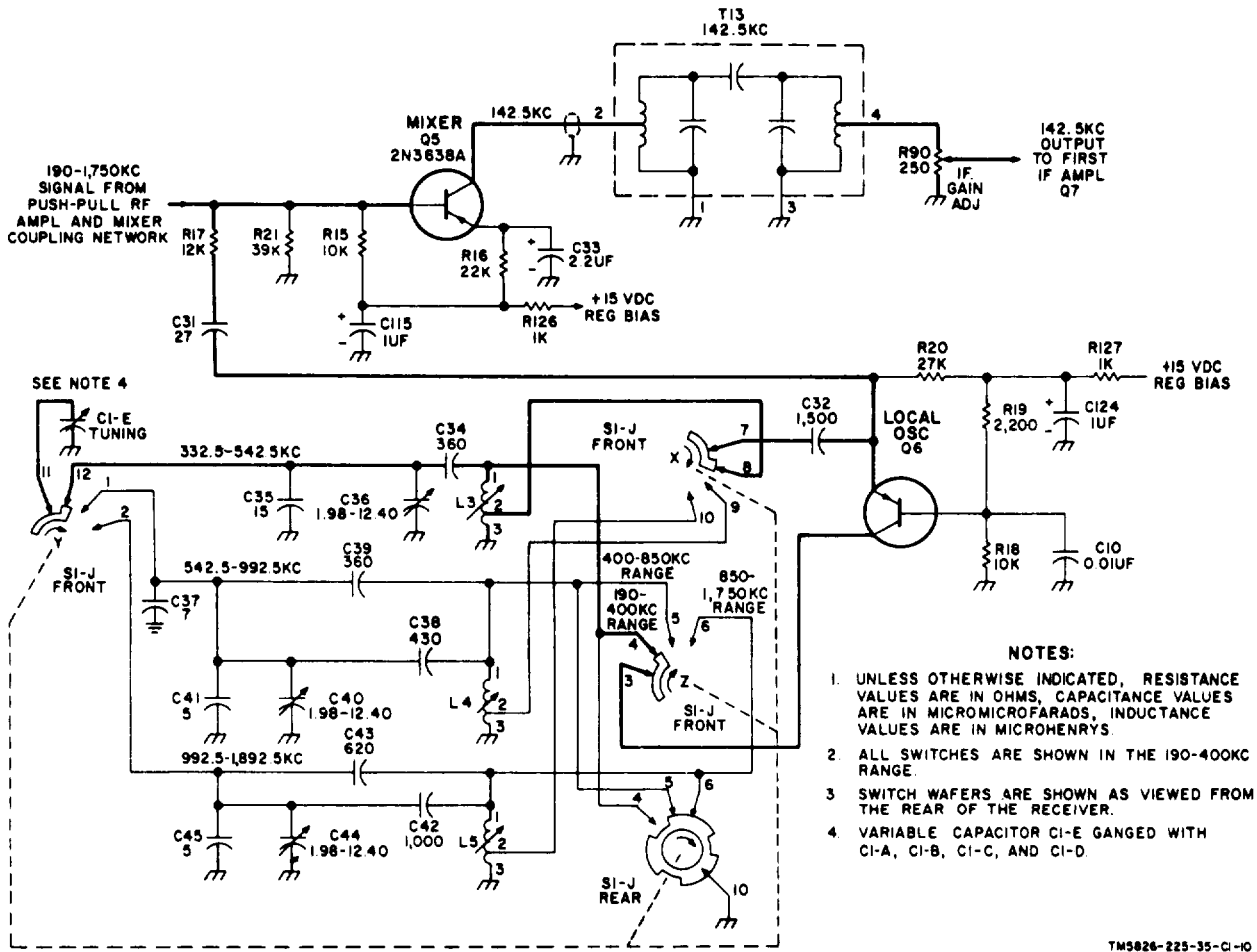

Figure 5-7. Mixer and local oscillator, schematic diagram.

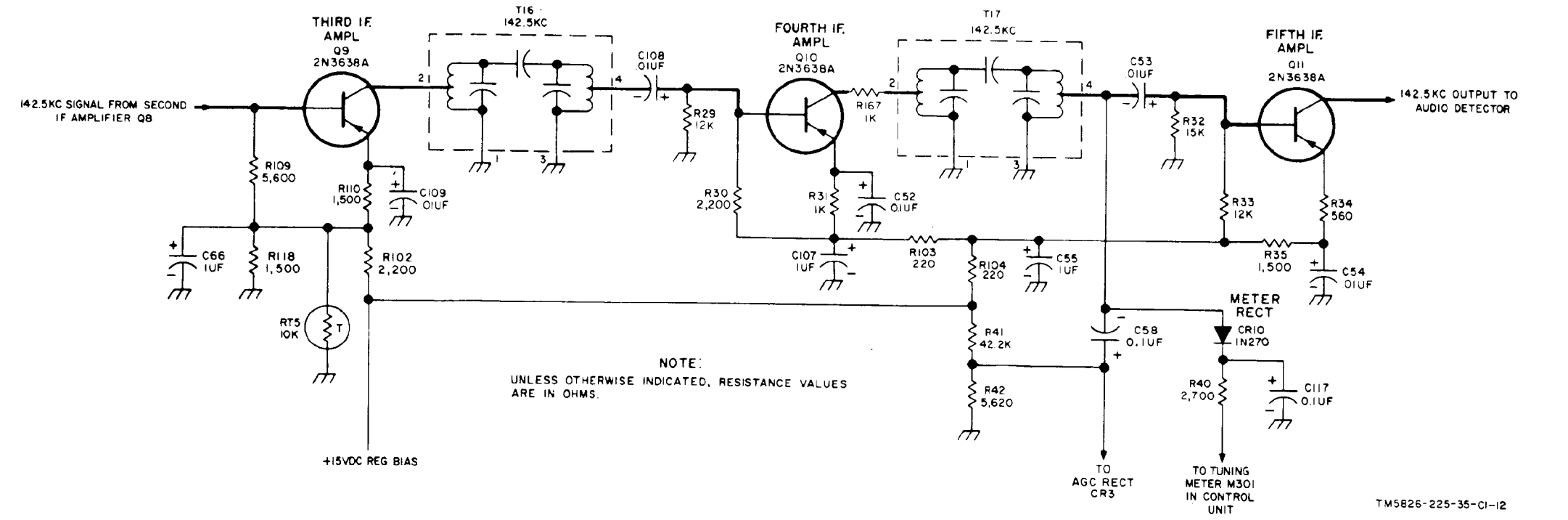

Figure 5-8. Third, fourth, and fifth IF amplifiers, schematic diagram.

TM5826-225-35-C1-12

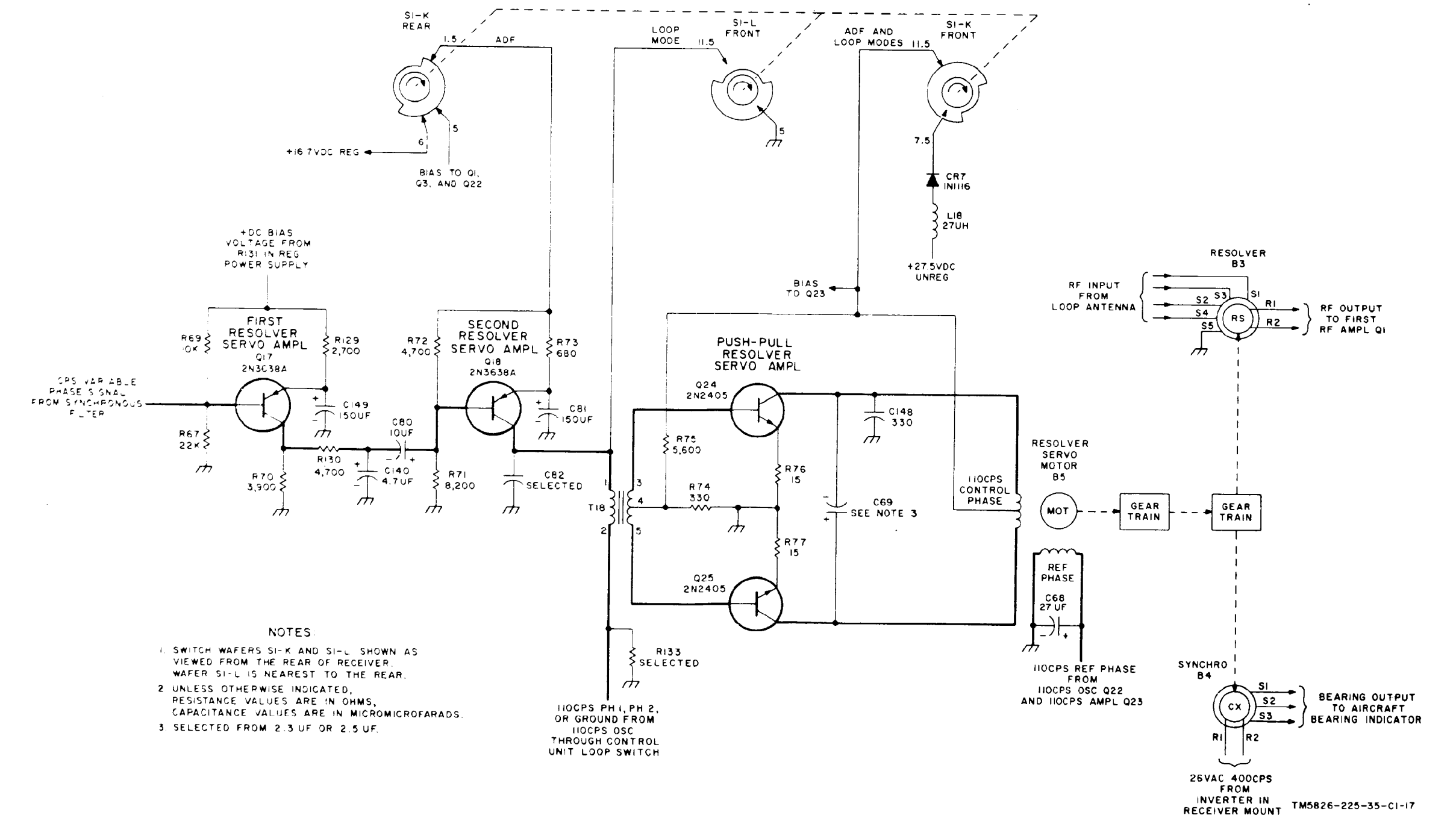

Figure 5-9. Resolver servoamplifier, schematic diagram.

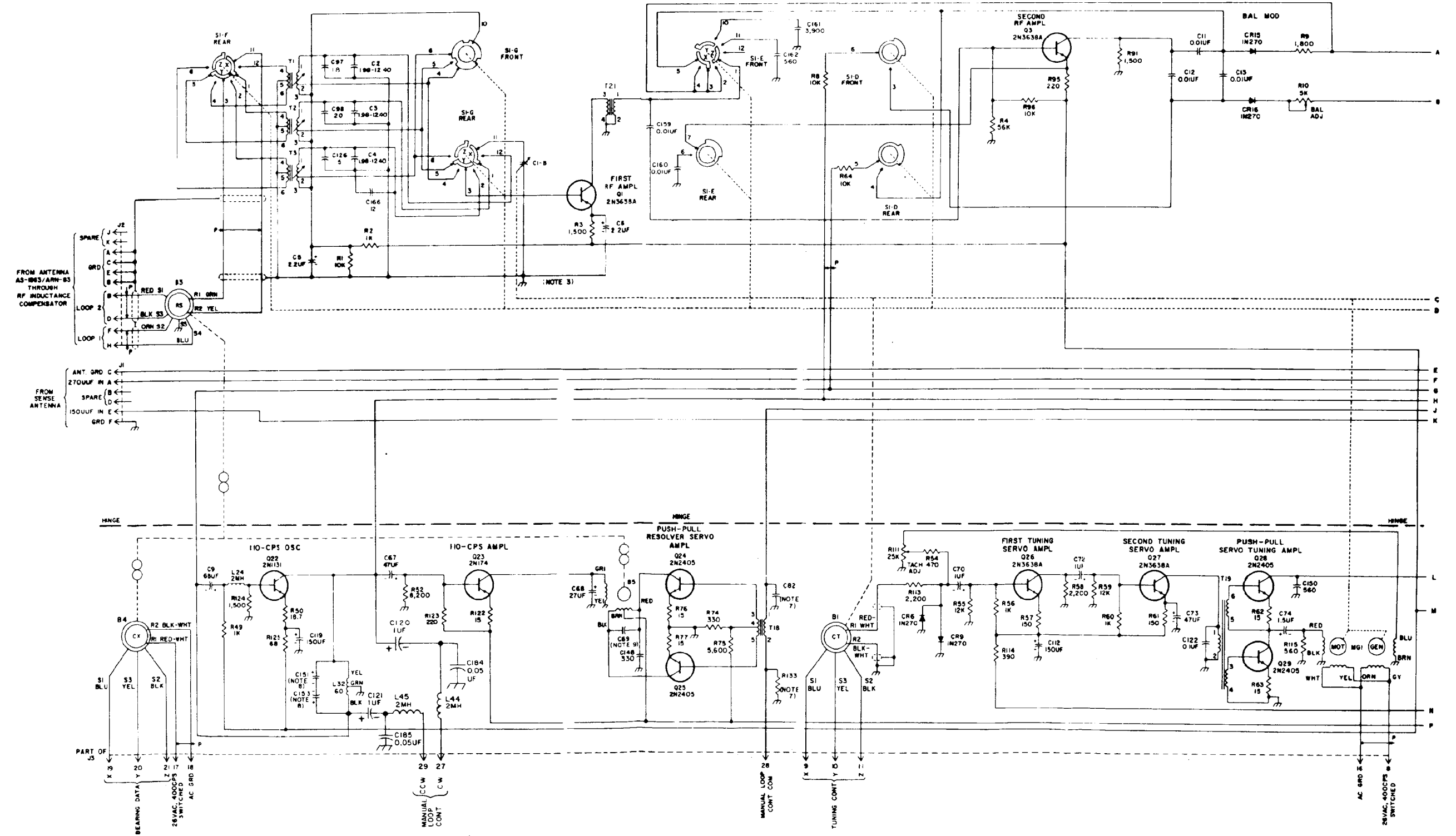

Figure 5-10.1 (1) Radio Receiver R-1491/A1N-83 (CPN 522-2587-000, MCN 11200 and above), schematic diagram (sheet 1 of 3).

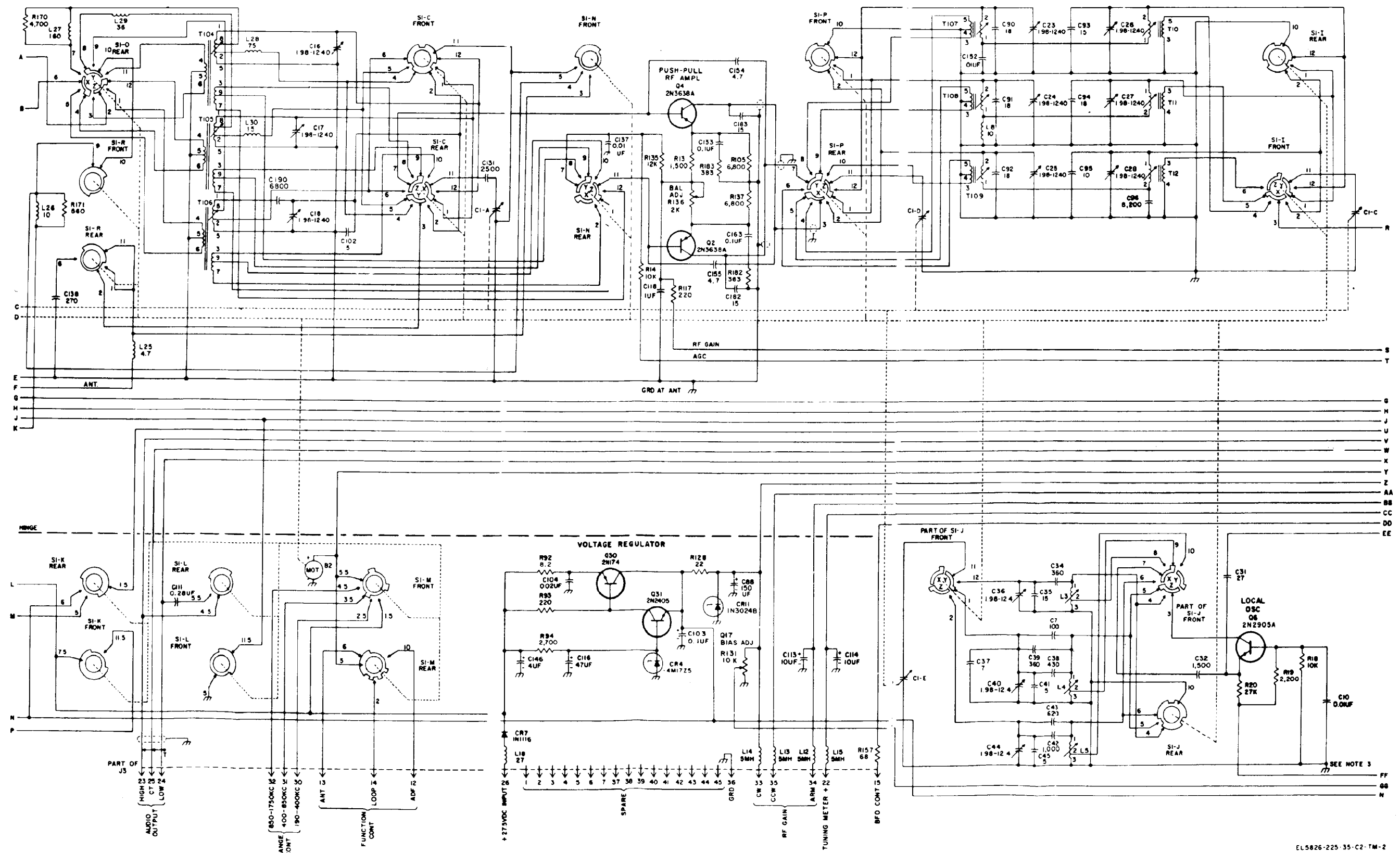
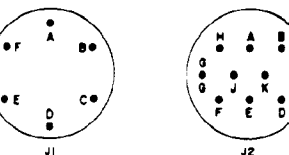
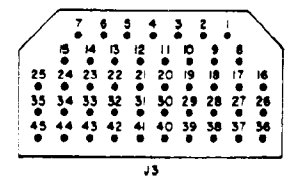

Figure 5-101 (2) Radio Receiver R-1391/ARN-83 (CPN 522-2587-000, MCN 11200 and above), schematic diagram (sheet 2 of 3).

- NOTES:
- UNLESS OTHERWISE INDICATED, RESISTANCE VALUES ARE IN OHMS; CAPACITANCE VALUES ARE IN MICROMICROFARADS, INDUCTANCE VALUES ARE IN MICROHENRYS.
 - RANGE AND FUNCTION SWITCHES ARE SHOWN AS VIEWED FROM THE REAR OF THE RECEIVER IN 400-850KC RANGE AND ANTENNA FUNCTION. SEQUENCE OF CLOCKWISE NOTATION IS:
 400-850KC, ANT BLANK
 850-1750KC, ANT BLANK
 1750-4000KC, ANT BLANK
 400-850KC, ADF BLANK
 850-1750KC, ADF BLANK
 1750-4000KC, ADF BLANK
 400-850KC, LOOP 400-850KC, LOOP
 850-1750KC, LOOP 850-1750KC, LOOP
 1750-4000KC, LOOP 1750-4000KC, LOOP
 - ALL POINTS ARE GROUNDED AT C1.
 - CLIP ON FRONT SECTION OF SWITCH INSULATED FROM CORRESPONDING CLIP ON REAR SECTION.
 - SEGMENT Z OF S1-E FRONT NOT USED.
 - RECEPTACLE VIEWED FROM PIN OR RECEPTACLE END.



- R133 AND C82 SELECTED FOR PROPER SERVO OPERATION VALUE FOR R133 WILL BE IN 1,200 TO 3,800 OHM RANGE VALUE FOR C82 WILL BE IN 0.5 TO 15 UF RANGE
- C151 AND C153 SELECTED. 47UF, 56UF, 68UF, OR 100UF.
- *C89 SELECTED 2.5UF OR 2.5UF.

ITEM	ACTION TAKEN	AT MCN NO
R90	CHANGED FROM 25 OHMS TO 187 OHMS	11508
R170	ADDED ACROSS L27	12916
R171	ADDED ACROSS L26	12918
R182	ADDED FROM C182 TO C183	12616
R182	CHANGED FROM 390 OHMS TO 583 OHMS	12918
R183	ADDED FROM C133 TO R105	12616
R183	CHANGED FROM 390 OHMS TO 383 OHMS	12918
C182	ADDED FROM Q2-C TO GROUND	12918
C183	ADDED FROM Q4-C TO GROUND	12918
L35	REPLACED WITH R183 FROM C133 TO R105	12616
L36	REPLACED WITH R182 FROM C183 TO R105	12616
CR11	CHANGED FROM IN775A TO IN3024B	16119
C131	CHANGED FROM 3000 PF TO 2500 PF	16119
C180	ADDED FROM T106-1 TO C18	16119
C184	ADDED	C170506
C185	ADDED	C170506
L44	ADDED	C170506
L45	ADDED	C170506
CR11	CHANGED FROM IN775A TO IN3024B	C 71015
C131	CHANGED FROM 3000 TO 2500 PF	C171173
C190	ADDED	C171173
C47	CHANGED FROM 0.01UF TO 0.1UF	C173046
C97	CHANGED FROM 20 TO 18 PF	C173395

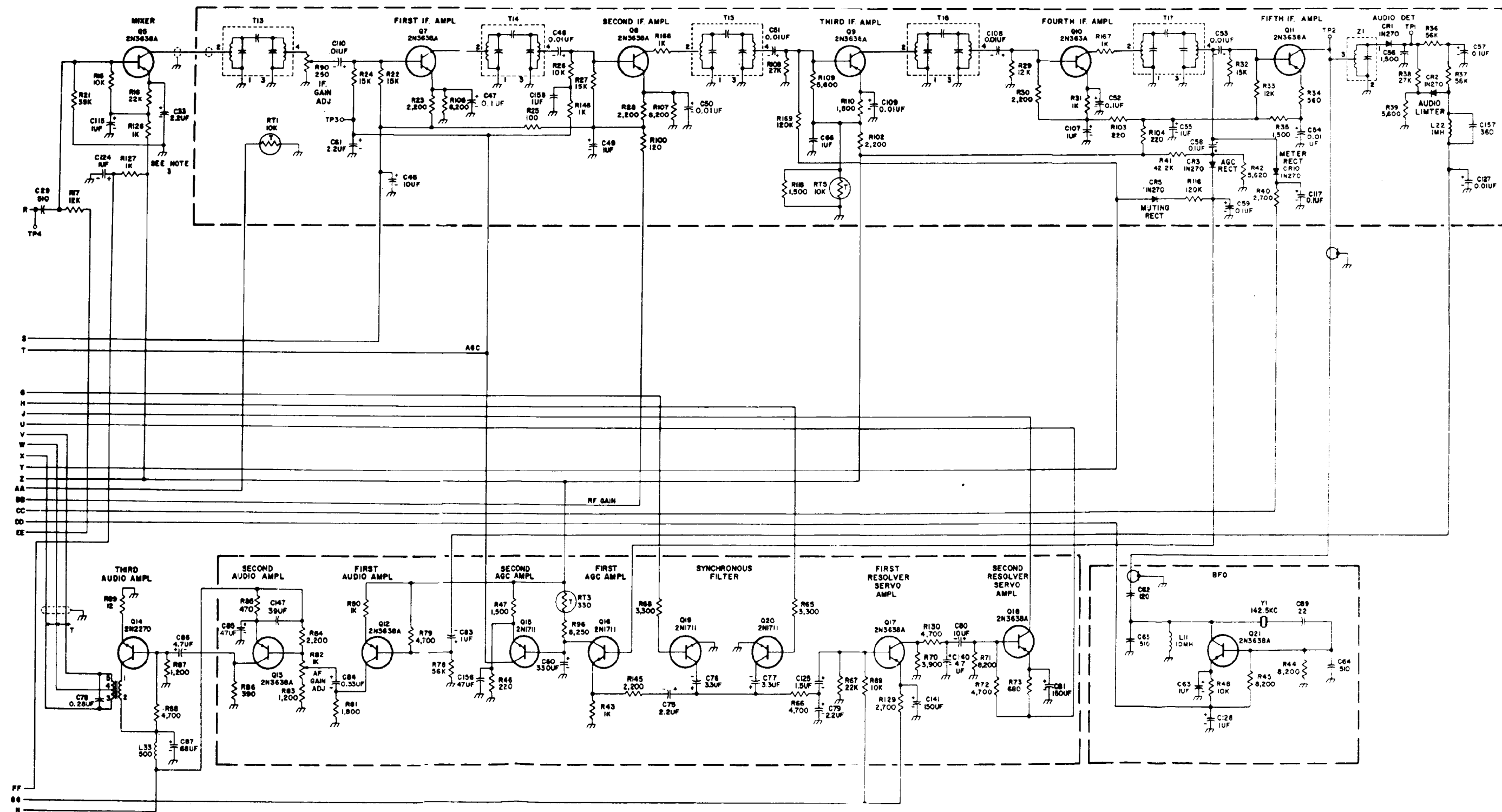

Figure 5-10.1 (1) Radio Receiver R-1391/ARN-83 (CPN 522-2587-000, MCN 1120) and above, schematic diagram (sheet 3 of 3).

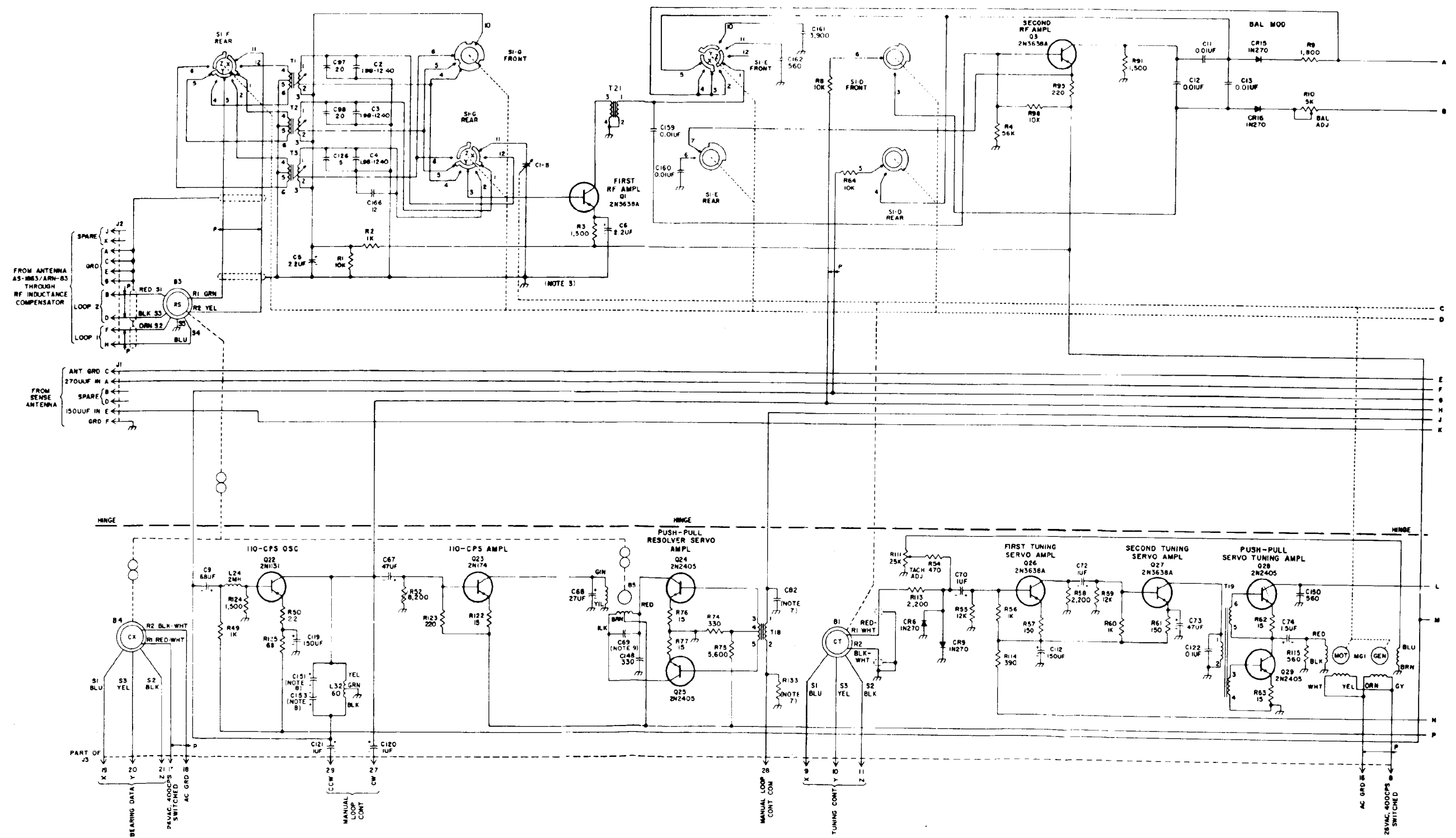

Figure 5-10, 2 (1) Radio Receiver R-1391/ARN-83 (CPN 522-2587-000, MCN 3053 through 11199), schematic diagram (sheet 1 of 3).

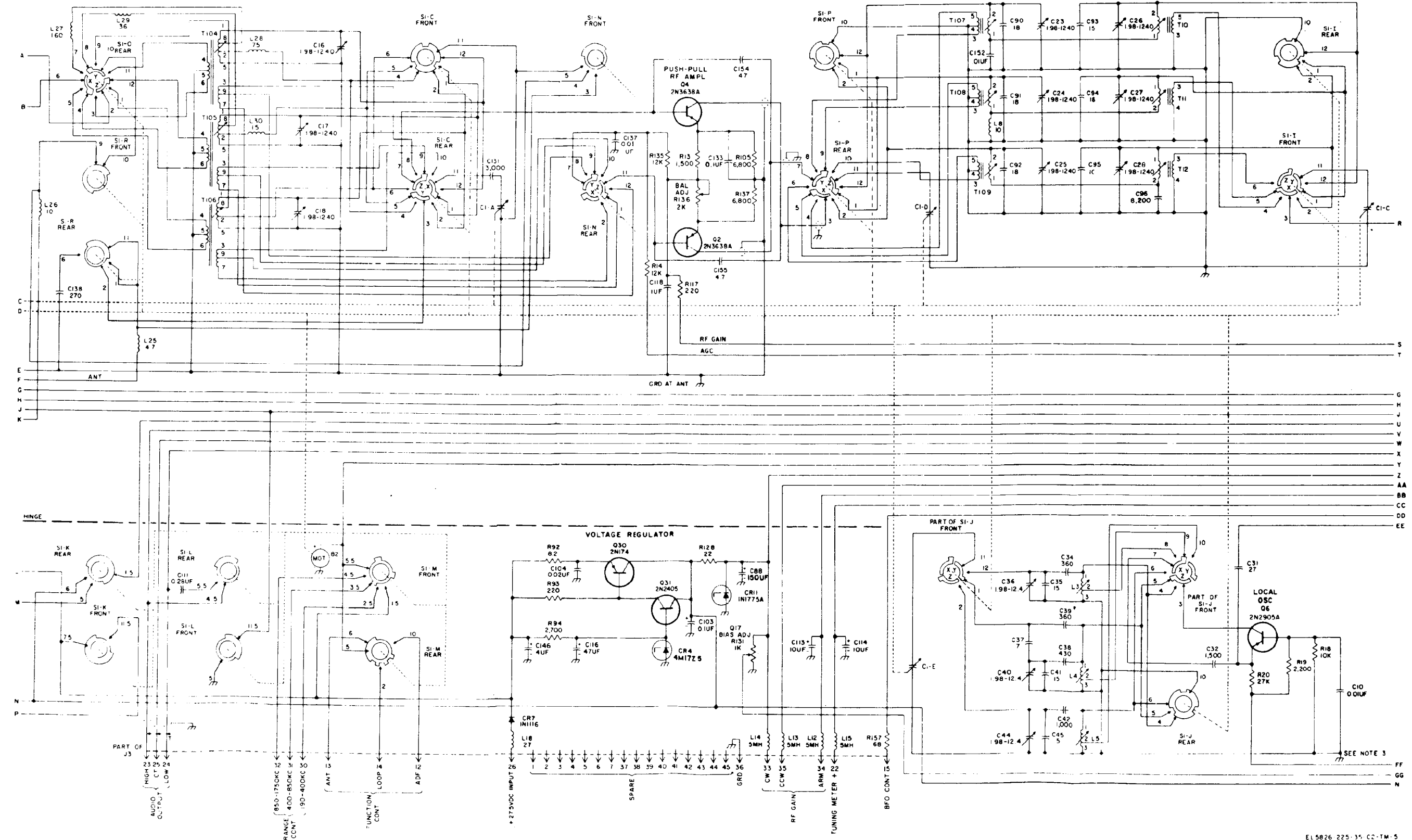
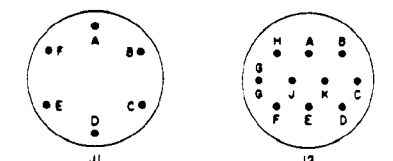
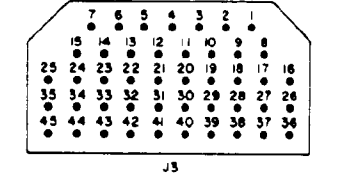

Figure 5-10.2 Radio Receiver R-1391/ARN-83 (CPN 522-2587-000, MCN 3053 through 11199), schematic diagram (sheet 2 of 3).

- NOTES:**
- UNLESS OTHERWISE INDICATED, RESISTANCE VALUES ARE IN OHMS, CAPACITANCE VALUES ARE IN MICROMICROFARADS, INDUCTANCE VALUES ARE IN MICROHENRYS.
 - RANGE AND FUNCTION SWITCHES ARE SHOWN AS VIEWED FROM THE REAR OF THE RECEIVER IN 400-850KC RANGE AND ANTENNA FUNCTION. SEQUENCE OF CLOCKWISE ROTATION IS:
 400-850KC, ANT. BLANK
 850-1750KC, ANT. 190-400KC, LOOP
 BLANK 400-800KC, LOOP
 190-400KC, ADF 850-1750KC, LOOP
 400-850KC, ADF BLANK
 850-1750KC, ADF 190-400KC, ANT.
 - ALL POINTS ARE GROUNDED AT C1.
 - CLIP ON FRONT SECTION OF SWITCH INSULATED FROM CORRESPONDING CLIP ON REAR SECTION.
 - SEGMENT Z OF S-E FRONT NOT USED.
 - RECEPTACLE VIEWED FROM PIN OR RECEPTACLE END.



- HISS AND CB2 SELECTED FOR PROPER SERVO OPERATION. VALUE FOR R133 WILL BE IN 1,200 TO 3,800 OHM RANGE. VALUE FOR CB2 WILL BE IN 0.5 TO 1.5 UF RANGE.
- C151 AND C153 SELECTED 47UF, 56UF, 68UF OR 100UF.

ITEM	CHANGE	AT MCN NUMBER
R22	FROM 12K TO 15K	2035
R40	FROM 3,300 TO 2,700	1807
R40	FROM 1K TO 680	1688
R130	FROM 1K TO 4700	1085
R185	ADDED	1084
CB7	FROM 10UF TO 68 UF	1861
C102	ADDED	2099

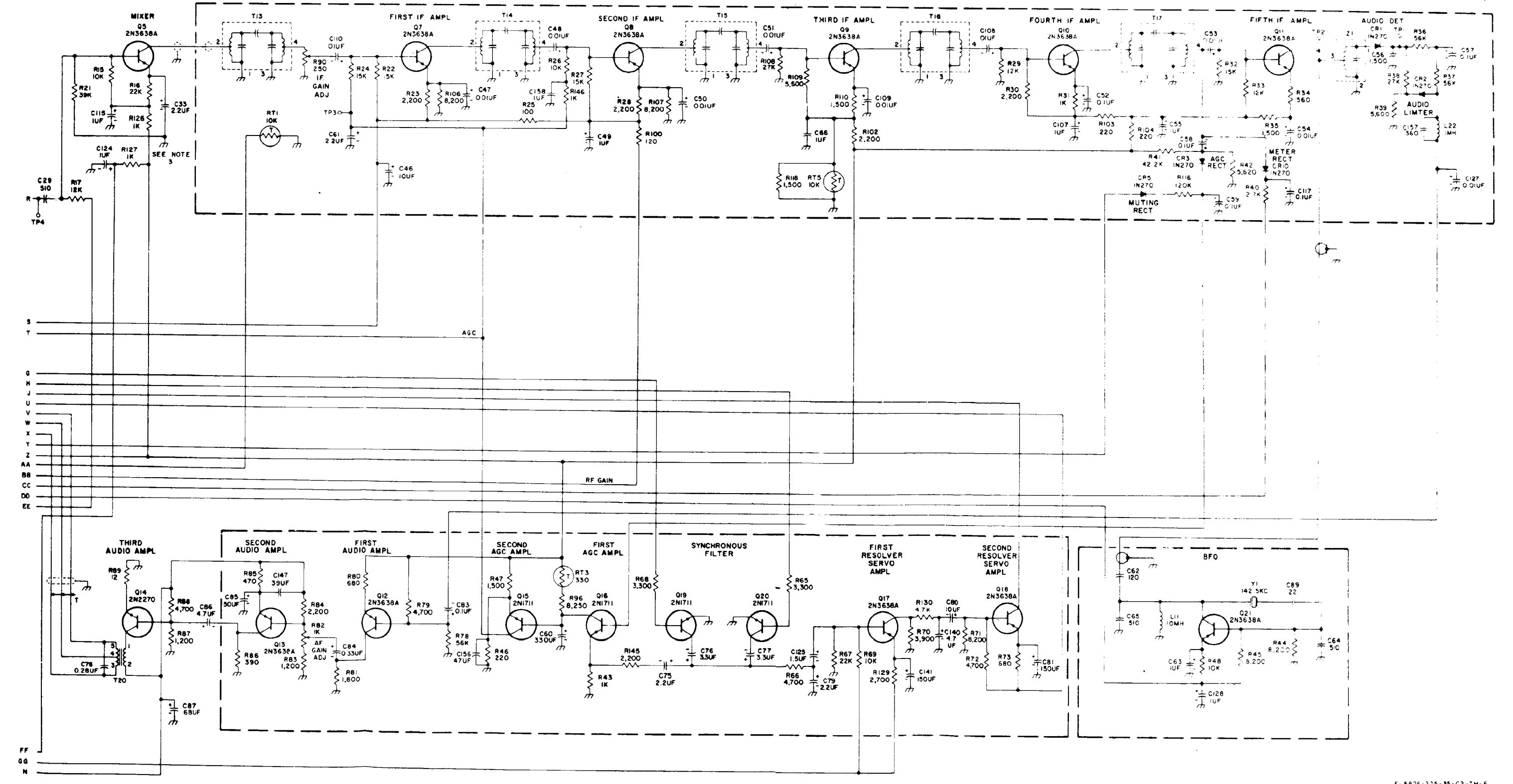

Figure 5-10.1 Radio Receiver R-191/ARN-83 (CPN 522-2587-000, MCN 3053 through 11190), schematic diagram (sheet 3 of 3).

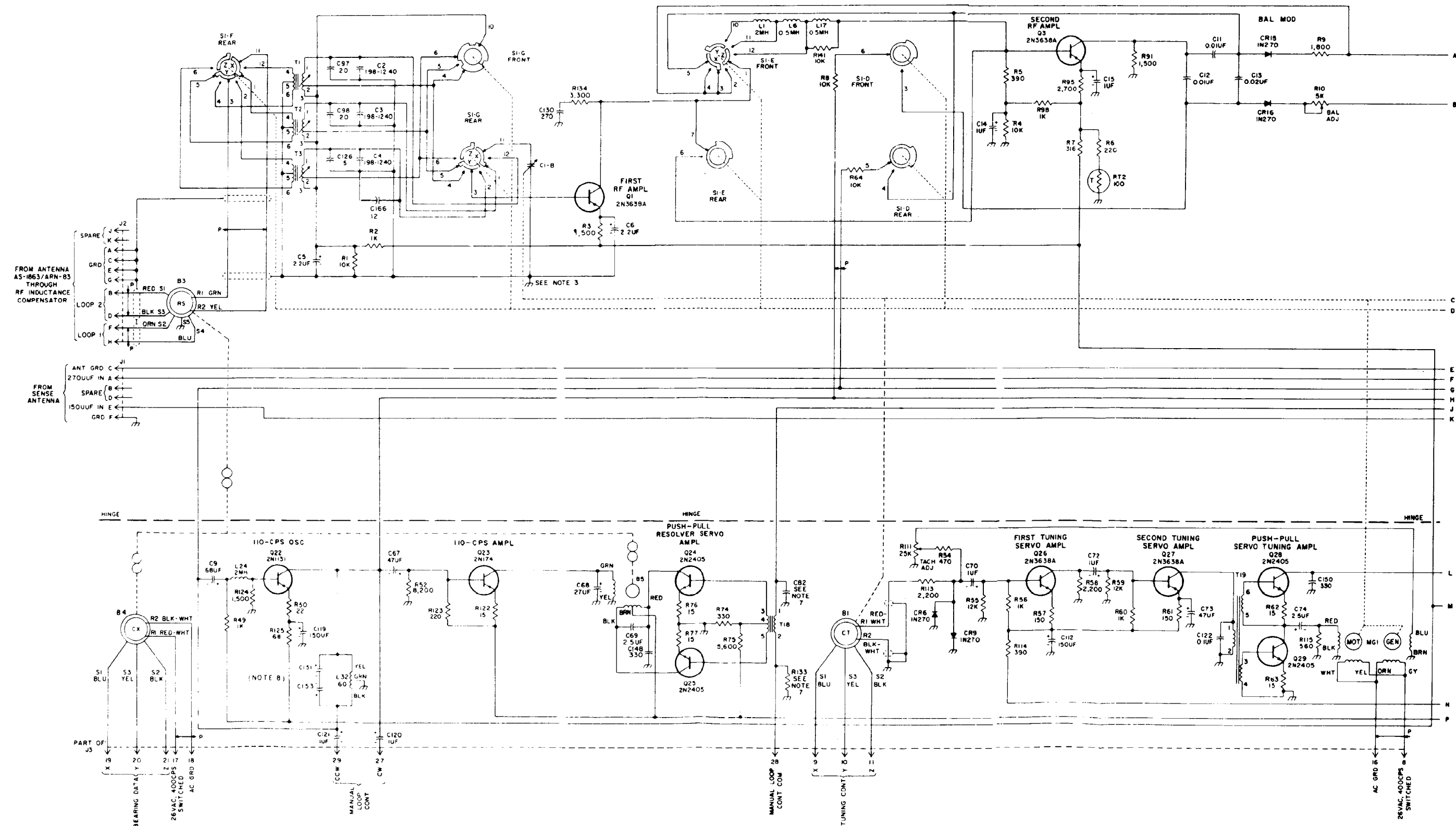

Figure 5-10.3 (1) Radio Receiver R-1391/ARN-83 (CPN 522-2587-000, MCN 1084 through 3052), schematic diagram (sheet 1 of 3).

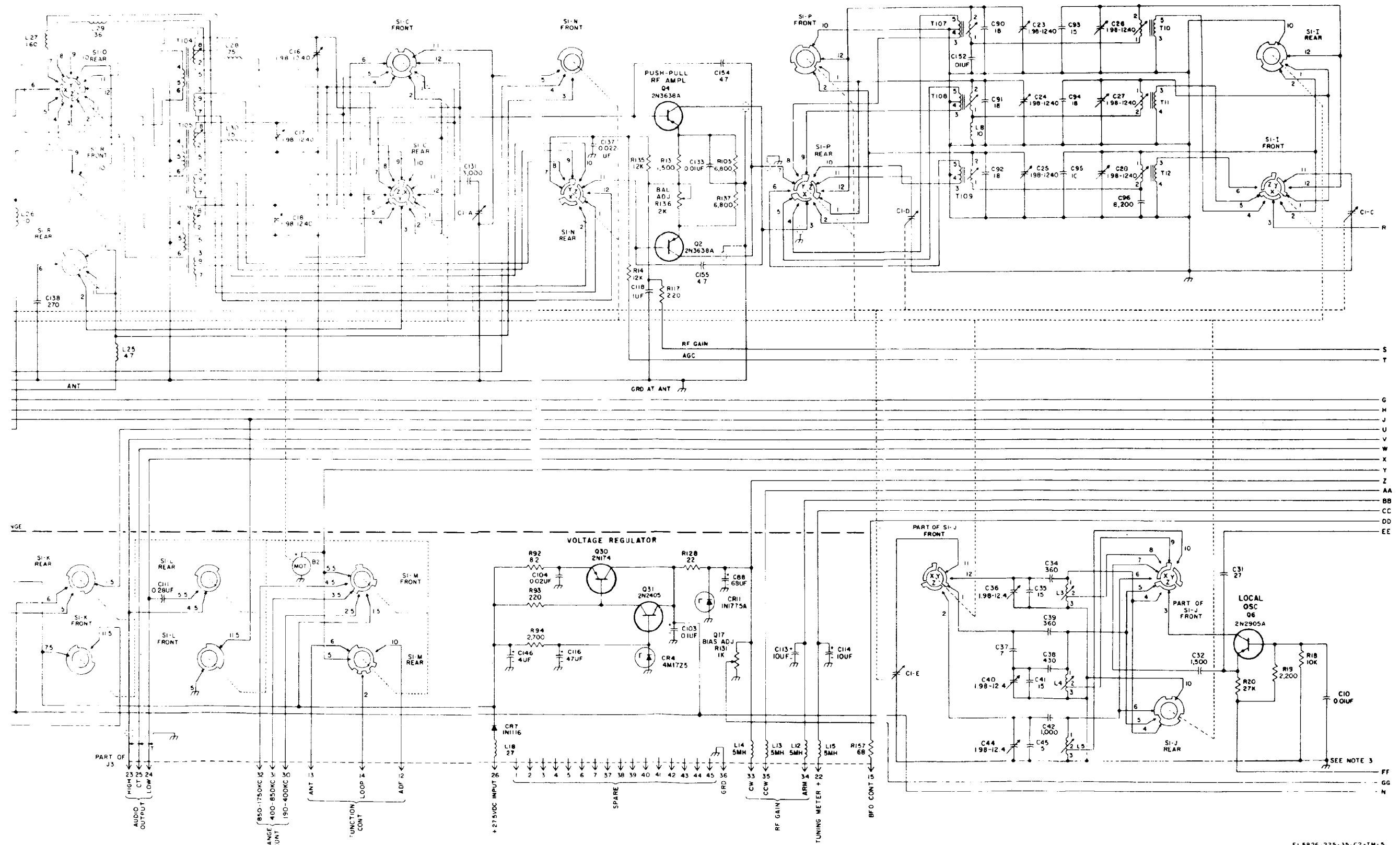
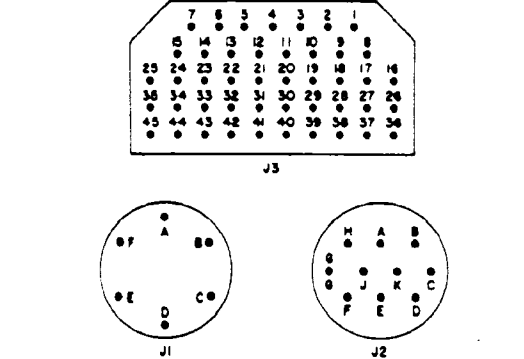

Figure 5-10.3 (2) Radio Receiver R-1391/ARN-83 (CPN 522-2587-000, MCN 1084 through 3052), schematic diagram (sheet 2 of 3).

- NOTES:**
- UNLESS OTHERWISE INDICATED, RESISTANCE VALUES ARE IN OHMS, CAPACITANCE VALUES ARE IN MICROMICROFARADS, INDUCTANCE VALUES ARE IN MICROHENRYS.
 - RANGE AND FUNCTION SWITCHES ARE SHOWN AS VIEWED FROM THE REAR OF THE RECEIVER IN 400-850KC RANGE AND ANTENNA FUNCTION. SEQUENCE OF CLOCKWISE ROTATION IS:

400-850KC. ANT.	BLANK
850-1750KC. ANT.	190-400KC. LOOP
BLANK	400-800KC. LOOP
190-400KC. ADF	850-1750KC. LOOP
400-800KC. ADF	BLANK
850-1750KC. ADF	190-400KC. ANT.
 - ALL POINTS ARE GROUNDED AT C1.
 - CLIP ON FRONT SECTION OF SWITCH INSULATED FROM CORRESPONDING CLIP ON REAR SECTION.
 - SEGMENT 2 OF S-I-E FRONT NOT USED.
 - RECEPTACLE VIEWED FROM PIN OR RECEPTACLE END.

7	8	2	4	3	2	1
9	14	13	12	11	10	9
23	24	23	22	21	20	19
36	34	33	32	31	30	29
45	44	43	42	41	40	39
6	9	8	7	6	5	4



- R23 AND C82 SELECTED FOR PROPER SERVO OPERATION. VALUE FOR R23 WILL BE IN 1,800 TO 3,900 OHM RANGE. VALUE FOR C82 WILL BE IN 0.5 TO 1.5 UF RANGE.
- C151 AND C153 SELECTED 47UF, 56UF, 68UF OR 100UF.
- C89 SELECTED, 2.5UF OR 2.5UF.
- R80 SELECTED, 470, 820, 1000, OR 1200 OHMS.

ITEM	CHANGE	AT MCN NUMBER
R4	FROM 10K TO 56K	3053
R5	REPLACED WITH A CIRCUIT	3053
R6	DELETED	3053
R7	REPLACED WITH A CIRCUIT	3053
R80	FROM 880 TO 1200	4727
R81	FROM 1200 TO 1K	8821
R85	FROM 2700 TO 1K	3053
R134	DELETED	3053
R141	DELETED	4727
R152	DELETED	4727
R165	DELETED	9428
R166	ADDED	4237
R167	ADDED	4237
R168	ADDED	7243
R169	ADDED	9079
RT2	DELETED	3053
C13	FROM 0.02UF TO 0.01UF	3053
C14	DELETED	3053
C16	DELETED	3053
C37	FROM 10PF TO 7PF	8089
C41	FROM 10PF TO 5PF	5204
C45	FROM 10PF TO 5PF	4727
C69	FROM 2.5UF TO SELECTED VALUE OF 2.5UF OR 2.5UF	7354
C74	FROM 2.5UF TO 1.5UF	9428
C83	FROM 0.1UF TO 1UF	4727
C88	FROM 8.5UF TO 15UF	4505
C130	DELETED	3053
C133	FROM 0.01UF TO 0.1UF	4727
C137	FROM 0.022UF TO 0.01UF	4727
C150	FROM 500PF TO 500PF	4727
C159	ADDED	3053
C160	ADDED	3053
C161	ADDED	3053
C62	ADDED	3053
C63	ADDED	4727
C148	DELETED	4727
T16	ADDED	7243
T21	ADDED	3053
L1	DELETED	3053
L6	DELETED	3053
L17	DELETED	4727
L31	ADDED	3053
L33	ADDED	4727
L35	ADDED	4727
L36	ADDED	4727

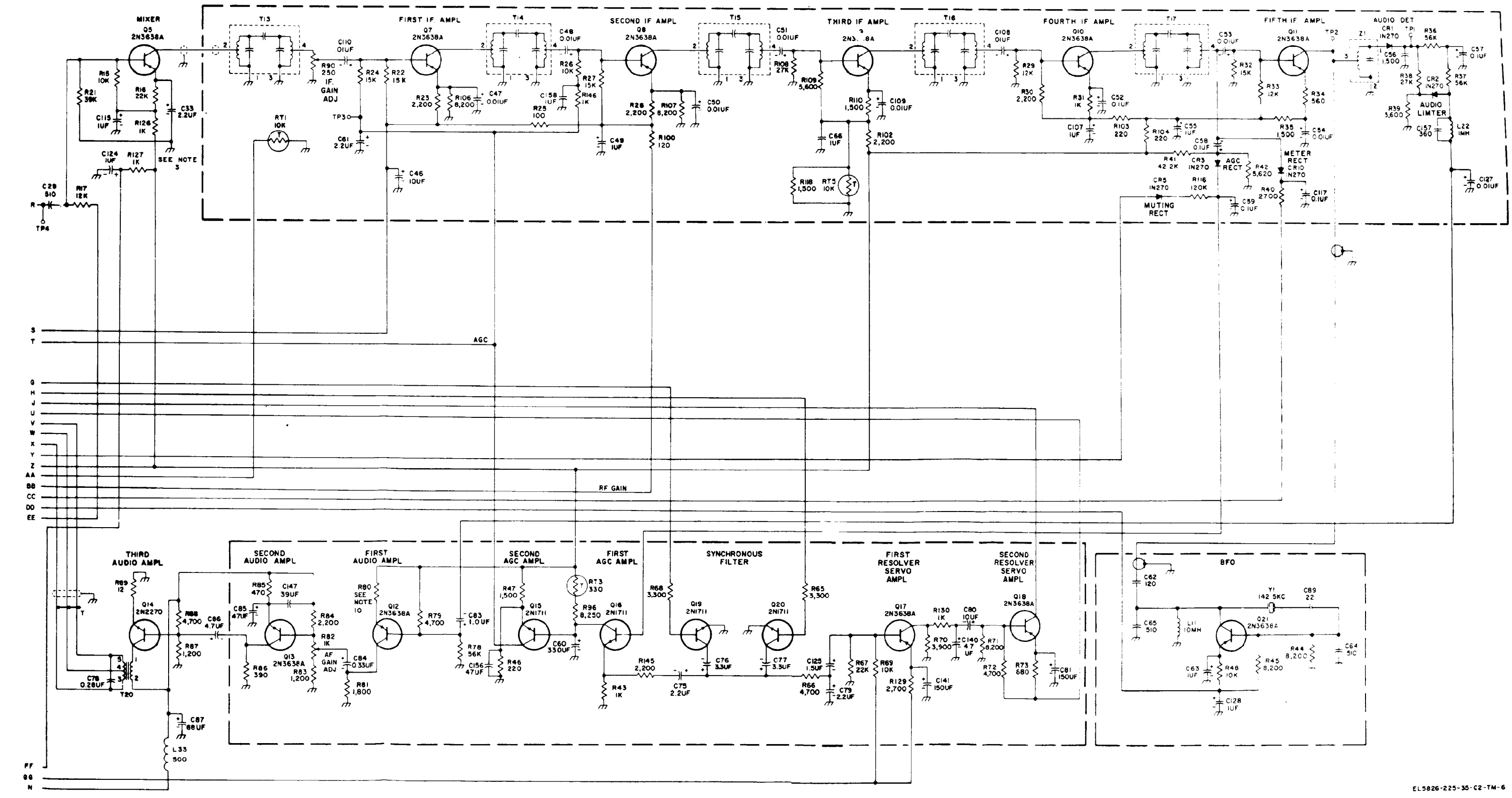

Figure 5-10.3 (1) Radio Receiver R-1391/ARN-83 (CPN 522-2587-000, MCN 1084 through 3052), schematic diagram (sheet 3 of 3).

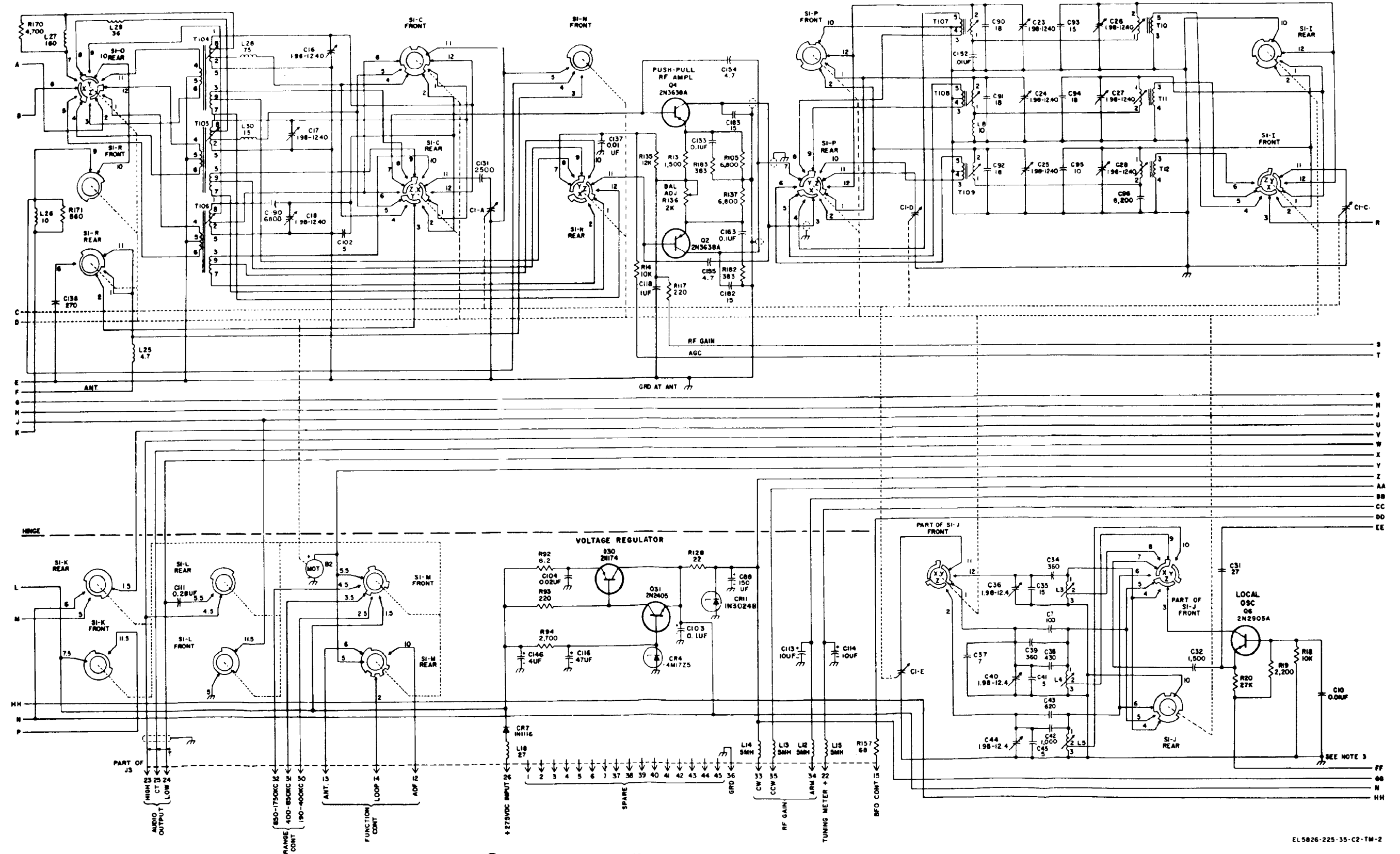
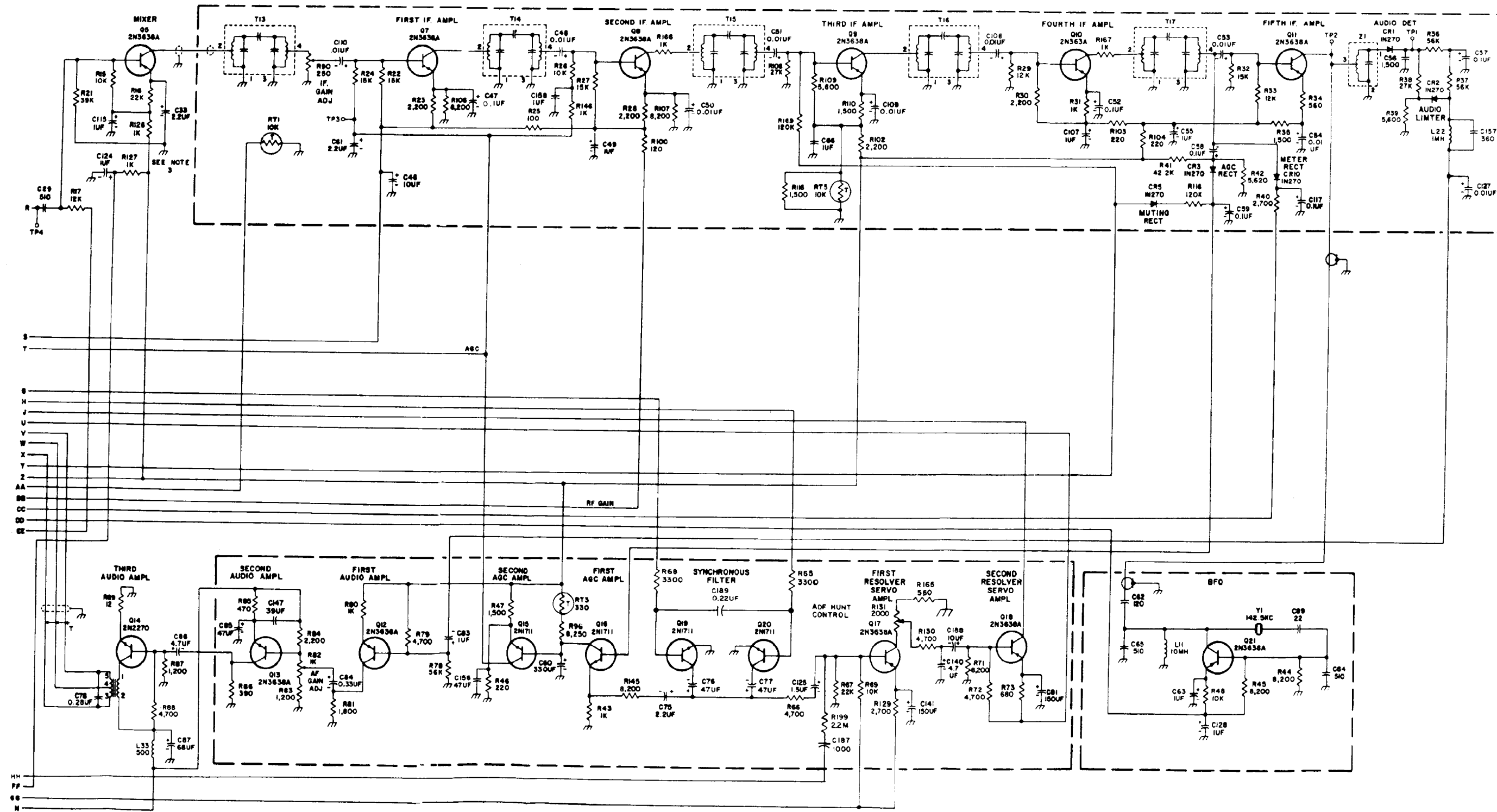
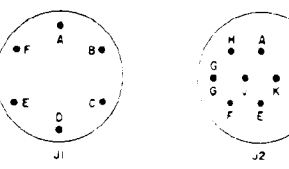
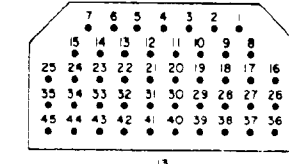

Figure 5-10.4 Radio Receiver R-1391/ARN-83 (CPN 522-2587-015), schematic diagram (sheet 2 of 3).



- NOTES
- UNLESS OTHERWISE INDICATED, RESISTANCE VALUES ARE IN OHMS, CAPACITANCE VALUES ARE IN MICROMICROFARADS, INDUCTANCE VALUES ARE IN MICROHENRYS
 - RANGE AND FUNCTION SWITCHES ARE SHOWN AS VIEWED FROM THE REAR OF THE RECEIVER IN 400-850KC RANGE AND ANTENNA FUNCTION SEQUENCE OF CLOCKWISE ROTATION IS

400-850KC, ANT	BLANK
850-1750KC, ANT	190-400KC, LOOP
BLANK	400-800KC, LOOP
190-400KC, ADF	850-1750KC, LOOP
400-850KC, ADF	BLANK
850-1750KC, ADF	190-400KC, ANT
 - ALL POINTS ARE GROUNDED AT C1
 - CLIP ON FRONT SECTION OF SWITCH INSULATED FROM CORRESPONDING CLIP ON REAR SECTION
 - SEGMENT Z OF 3-1-E FRONT NOT USED
 - RECEPTACLE VIEWED FROM PIN OR RECEPTACLE END



- R133 AND C82 SELECTED FOR PROPER SERVO OPERATION. VALUE FOR R133 WILL BE IN 1,200 TO 3,900 OHM RANGE. VALUE FOR C82 WILL BE IN 0.5 TO 5 UF RANGE.
- C151 AND C153 SELECTED. 47UF, 56UF, 68UF, OR 100UF.
- C89 SELECTED. 2.5UF OR 2.5UF.

Figure 3-10.4 (3) Radio Receiver R-1391/ARN-83 (CPN 522-2587-015), schematic diagram (sheet 3 of 3).

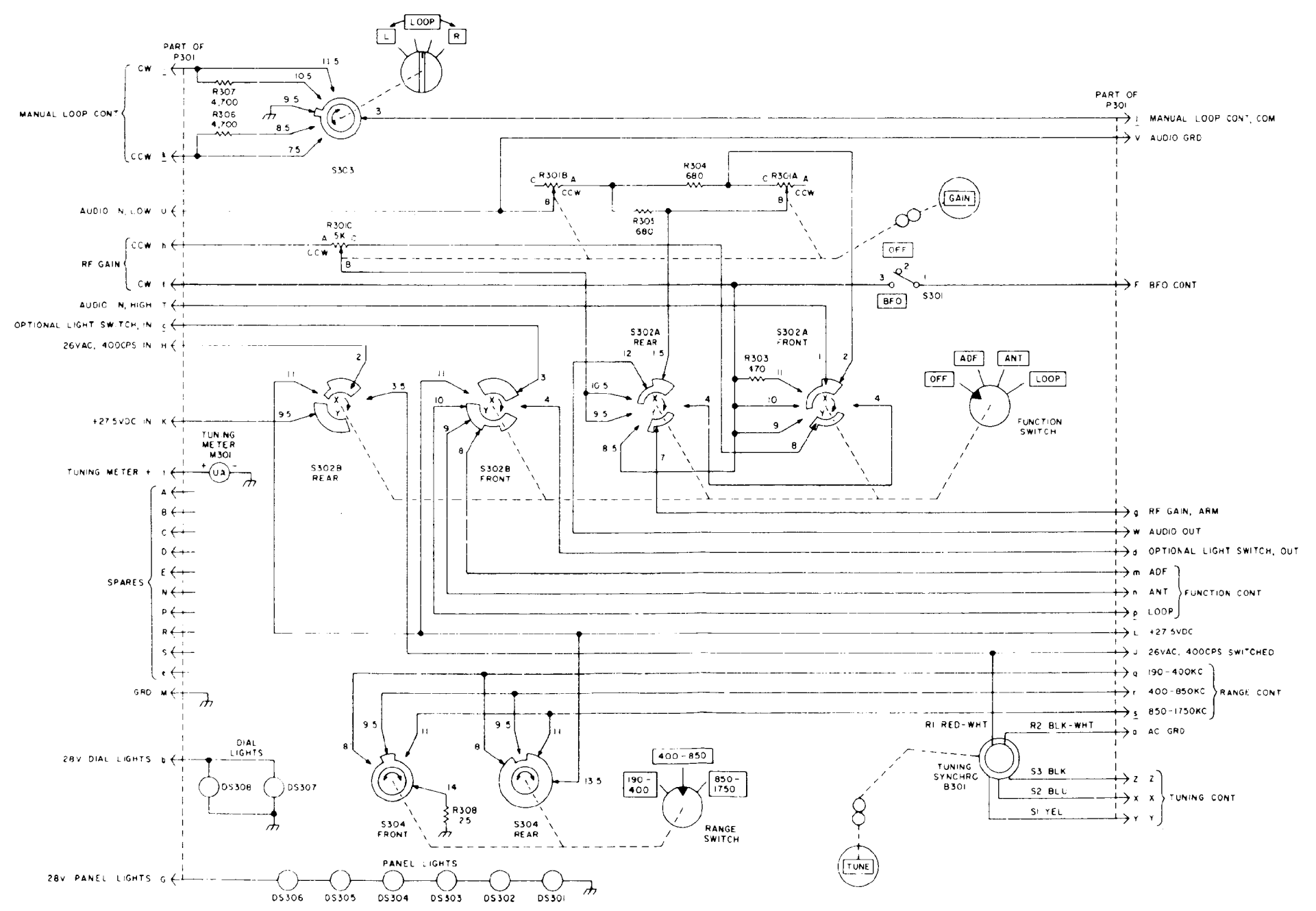

- NOTES
- 1 UNLESS OTHERWISE INDICATED, RESISTANCE VALUES ARE IN OHMS
 - 2 INDICATE EQUIPMENT MARKINGS
 - 3 UNLESS OTHERWISE INDICATED, SWITCHES ARE VIEWED FROM KNOB OR DRIVEN END

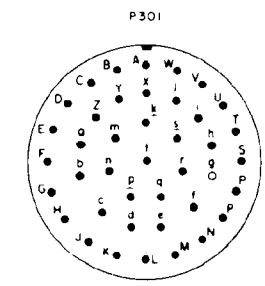
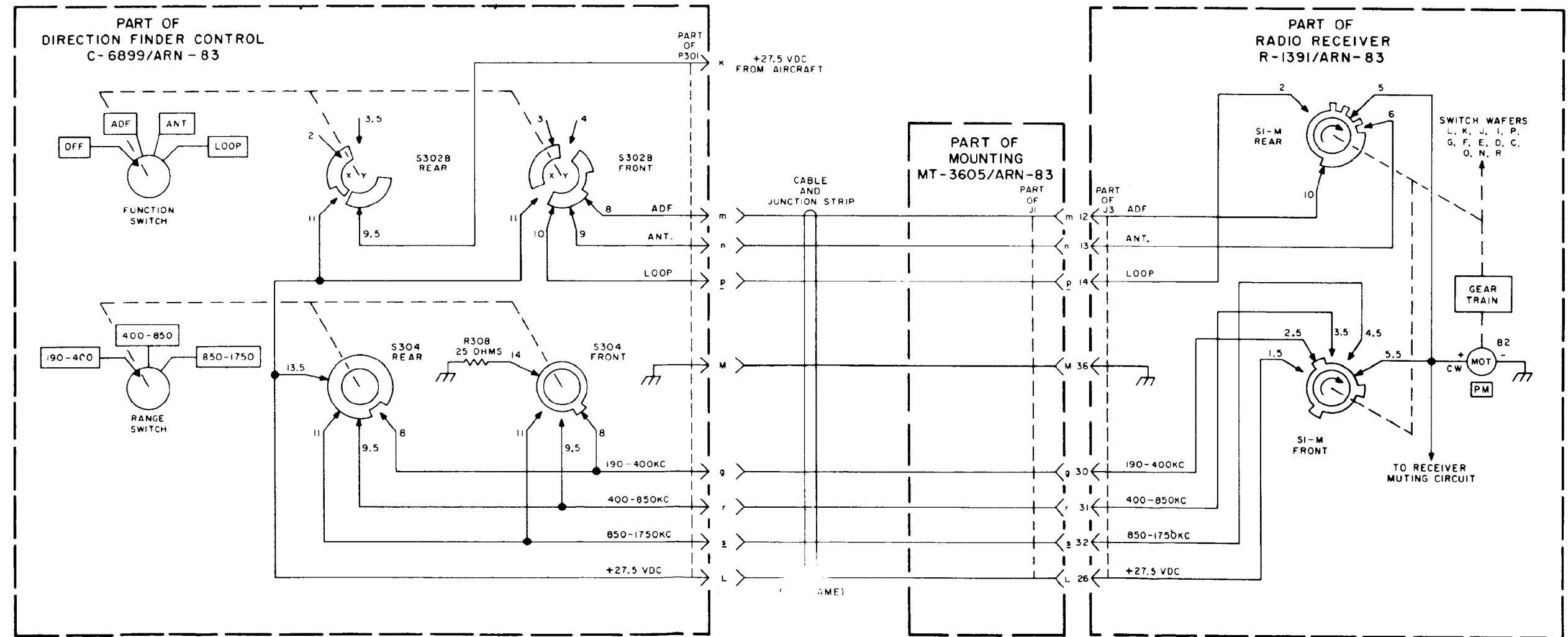

Figure 5-11. Direction Finder Control C-6899/ARN-83, schematic diagram.



- NOTES:
1. SWITCH S302 SHOWN IN OFF POSITION AND S304 SHOWN IN 190-400KC RANGE. SWITCHES ARE SHOWN AS VIEWED FROM THE SIDE FACING CONTROL KNOB.
 2. SWITCH SI-M SHOWN IN ADF MODE AND IN 190-400KC RANGE. SWITCH SHOWN AS VIEWED FROM THE REAR OF RECEIVER.
 3. INDICATES EQUIPMENT MARKING

Figure 5-12. Function and frequency range selection, schematic diagram.

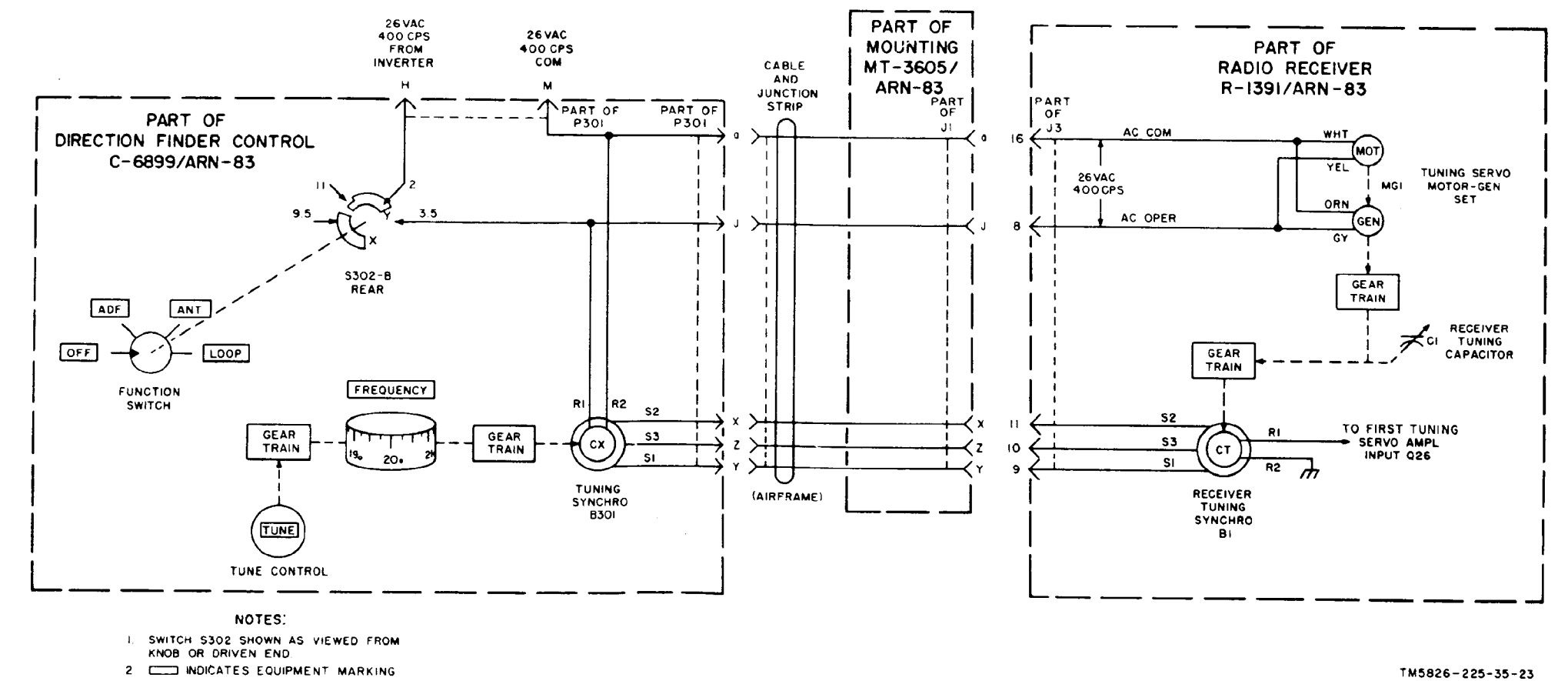

Figure 5-13. Receiver tuning, schematic diagram.

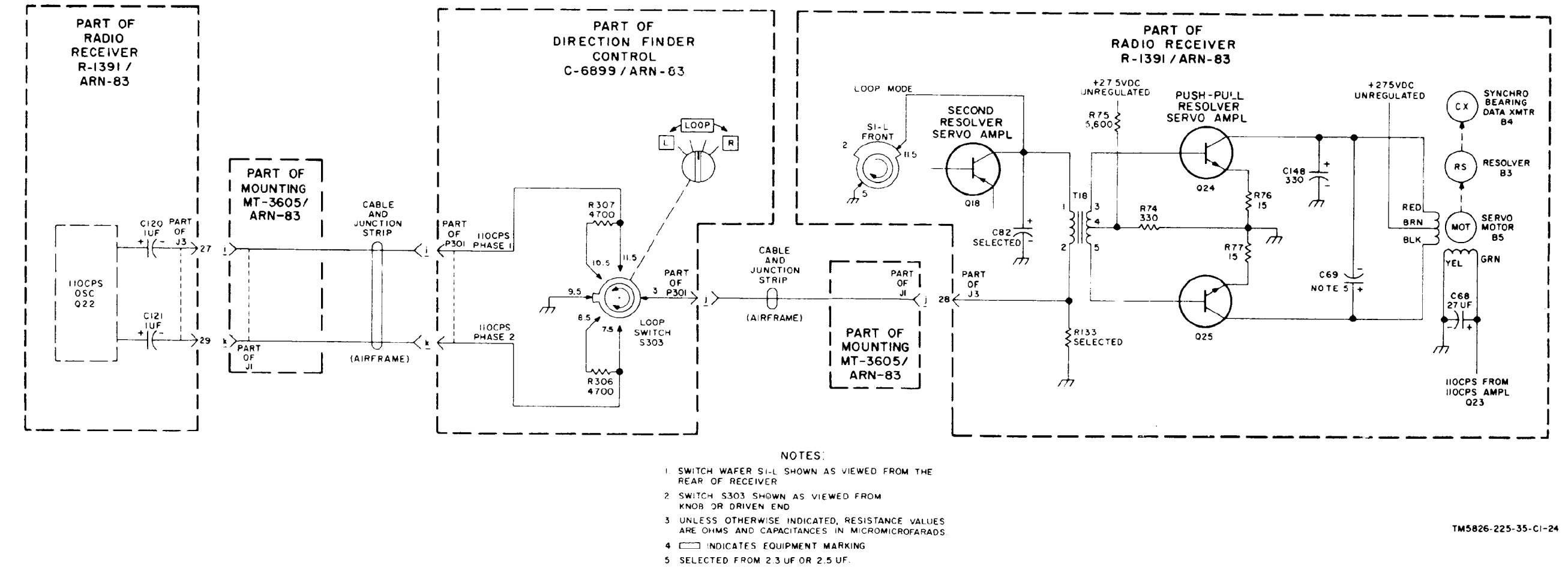
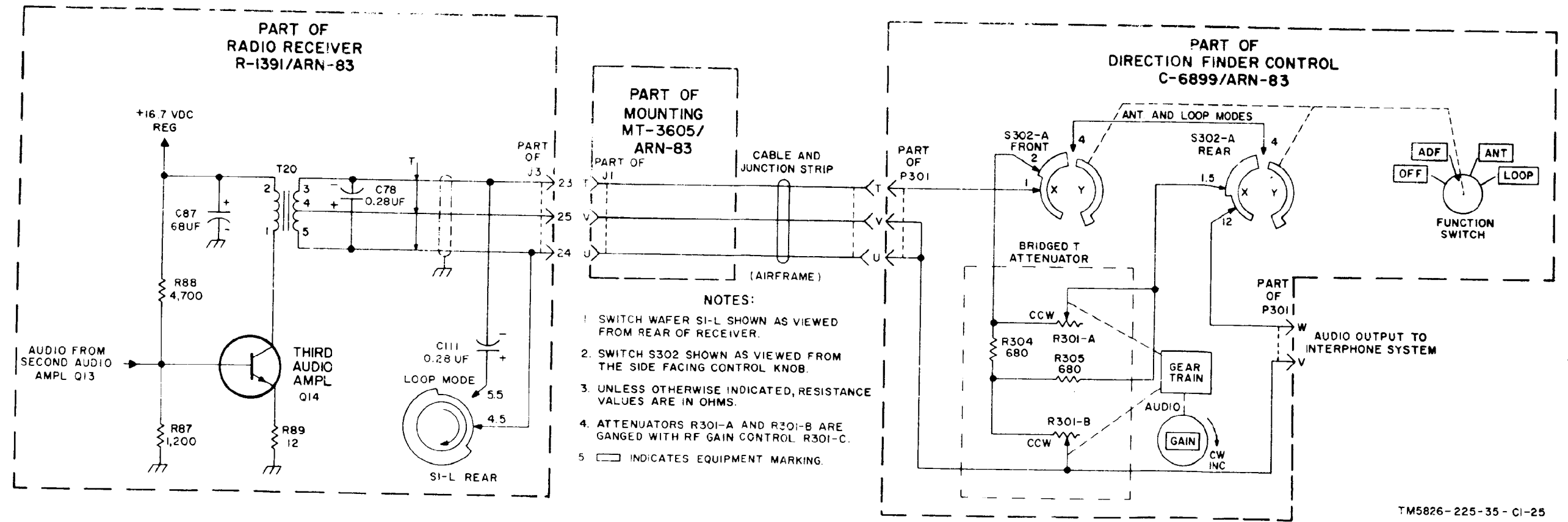
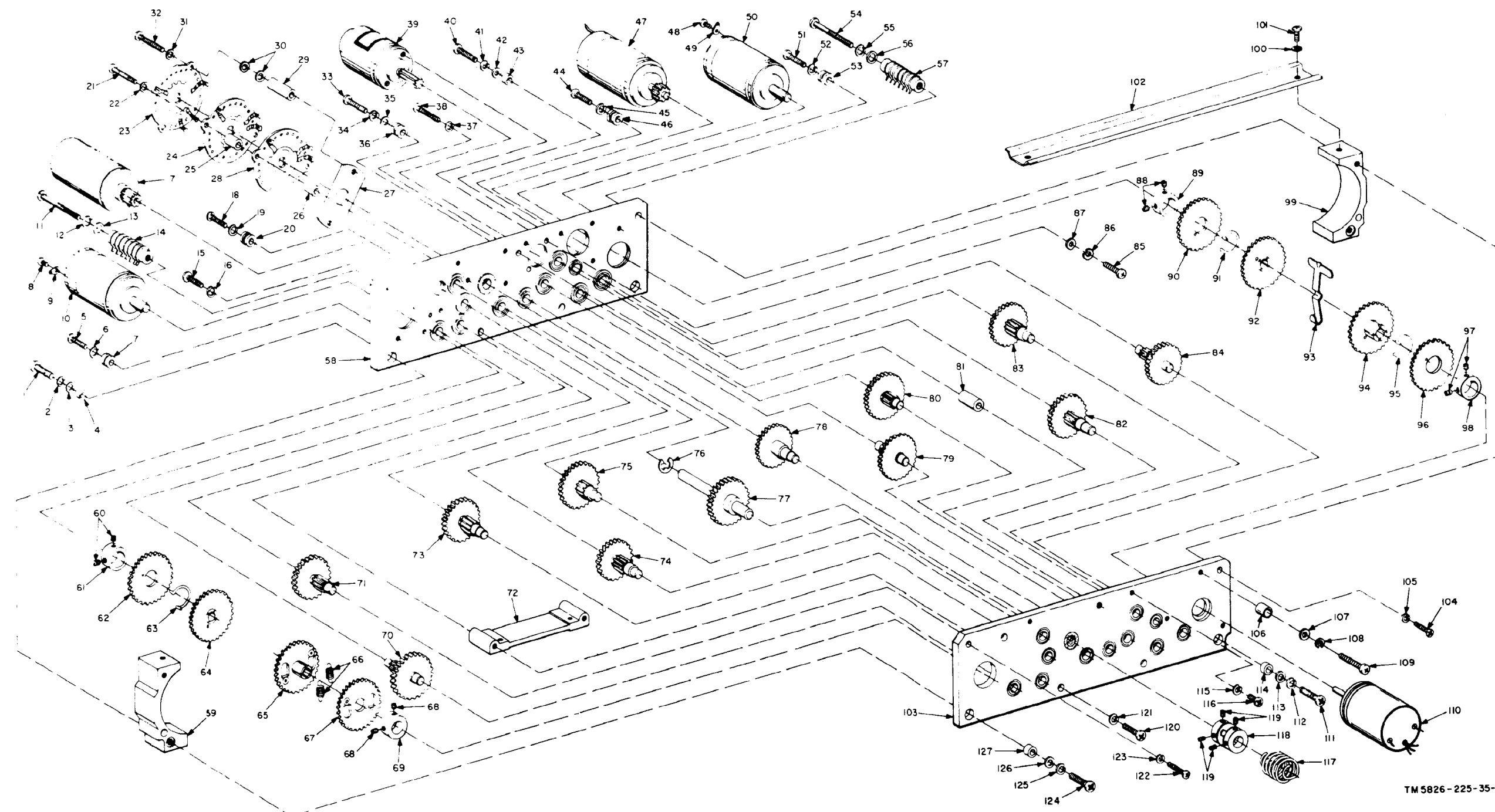

Figure 5-14. Manual loop control, schematic diagram.



TM5826-225-35-CI-25

Figure 5-15. Manual audio gain control, schematic diagram.



- | | | | | | |
|----|--|----|--|-----|--|
| 1 | Screw, 1/2 in. lg | 47 | Servomotor B5 | 83 | Spur gear assembly, 21 teeth and 60 teeth. |
| 2 | Lockwasher | 48 | Screw | 84 | Spur gear assembly, two 17 teeth and one 70 teeth. |
| 3 | Flat washer | 49 | Terminal lg | 85 | Screw, 5/16 in. lg |
| 4 | Dowel | 50 | Bearing synchro transmitter B4. | 86 | Lockwasher |
| 5 | Screw, 3/8 in. lg | 51 | Screw, 3/8 in. lg | 87 | Flat washer |
| 6 | Lockwasher | 52 | Lockwasher | 88 | Lockwasher |
| 7 | Rim clamp | 53 | Rim clamp | 89 | Collar |
| 8 | Screw | 54 | Screw, 1 1/2 in. lg | 90 | Spur gear, 95 teeth |
| 9 | Terminal lug | 55 | Lockwasher | 91 | Load spring |
| 10 | Tuning synchro control transformer B1. | 56 | Flat washer | 92 | Spur gear, hubbed, 95 teeth |
| 11 | Screw, 1 1/2 in. lg | 57 | Terminal post | 93 | Electrical contact |
| 12 | Lockwasher | 58 | Rear gear plate | 94 | Spur gear, hubbed, 95 teeth |
| 13 | Flat washer | 59 | Housing | 95 | Load spring |
| 14 | Terminal post | 60 | Set screw | 96 | Spur gear, 95 teeth |
| 15 | Screw, 3/8 in. lg | 61 | Collar | 97 | Set screw |
| 16 | Lockwasher | 62 | Spur gear, 84 teeth | 98 | Collar |
| 17 | Servo motor-generator set MG1. | 63 | Load spring | 99 | Housing |
| 18 | Screw, 1/8 in. lg | 64 | Spur gear, hubbed, 84 teeth | 100 | Lockwasher |
| 19 | Lockwasher | 65 | Tuning capacitor drive gear, hubbed, 84 teeth. | 101 | Screw, 1 4 in. lg |
| 20 | Rim clamp | 66 | Extension spring | 102 | Cover |
| 21 | Screw, 7/8 in. lg | 67 | Tuning capacitor drive gear, 84 teeth. | 103 | Front gear plate |
| 22 | Nonmetallic washer | 68 | Set screw | 104 | Screw, 3 8 in. lg |
| 23 | Switch wafer S1-M | 69 | Tuning capacitor shaft collar | 105 | Lockwasher |
| 24 | Switch wafer S1-L | 70 | Spur gear assembly, two 17 teeth and one 80 teeth. | 106 | Spacer, 0.106 in. lg |
| 25 | Spacer, 1/4 in. lg | 71 | Spur gear assembly, 17 teeth and 65 teeth. | 107 | Flat washer |
| 26 | Spacer, 5/16 in. lg | 72 | Side plate | 108 | Lockwasher |
| 27 | Switch plate | 73 | Spur gear assembly, 17 teeth and 65 teeth. | 109 | Screw, 5 16 in. lg |
| 28 | Switch wafer S1-K | 74 | Spur gear assembly, 17 teeth and 50 teeth. | 110 | Resolver B3 |
| 29 | Spacer, 3/4 in. lg | 75 | Spur gear assembly, 17 teeth and 64 teeth. | 111 | Screw, 1 2 in. lg |
| 30 | Nonmetallic washer | 76 | Retaining ring | 112 | Lockwasher |
| 31 | Nonmetallic washer | 77 | Spur gear assembly, 48 teeth and 60 teeth. | 113 | Flat washer |
| 32 | Screw, 1 in. lg | 78 | Spur gear assembly, 17 teeth and 60 teeth. | 114 | Dowel |
| 33 | Screw, 3/8 in. lg | 79 | Spur gear assembly, 17 teeth and 60 teeth. | 115 | Lockwasher |
| 34 | Lockwasher | 80 | Spur gear assembly, 17 teeth and 61 teeth. | 116 | Screw, 3 16 in. lg |
| 35 | Flat washer | 81 | Spacer, 0.687 in. lg | 117 | Extension spring |
| 36 | Switch clamp | 82 | Spur gear assembly, 17 teeth and 49 teeth. | 118 | Switch shaft coupler |
| 37 | Lockwasher | | | 119 | Set screw |
| 38 | Screw, 1 in. lg | | | 120 | Screw, 3 8 in. lg |
| 39 | Motor B2 | | | 121 | Lockwasher |
| 40 | Screw, 1/2 in. lg | | | 122 | Screw, 3 8 in. lg |
| 41 | Lockwasher | | | 123 | Lockwasher |
| 42 | Flat washer | | | 124 | Screw, 1/2 in. lg |
| 43 | Dowel | | | 125 | Lockwasher |
| 44 | Screw, 3/8 in. lg | | | 126 | Flat washer |
| 45 | Lockwasher | | | 127 | Dowel |
| 46 | Rim clamp | | | | |

Figure 5-16. Receiver, gear train subassembly, exploded view.

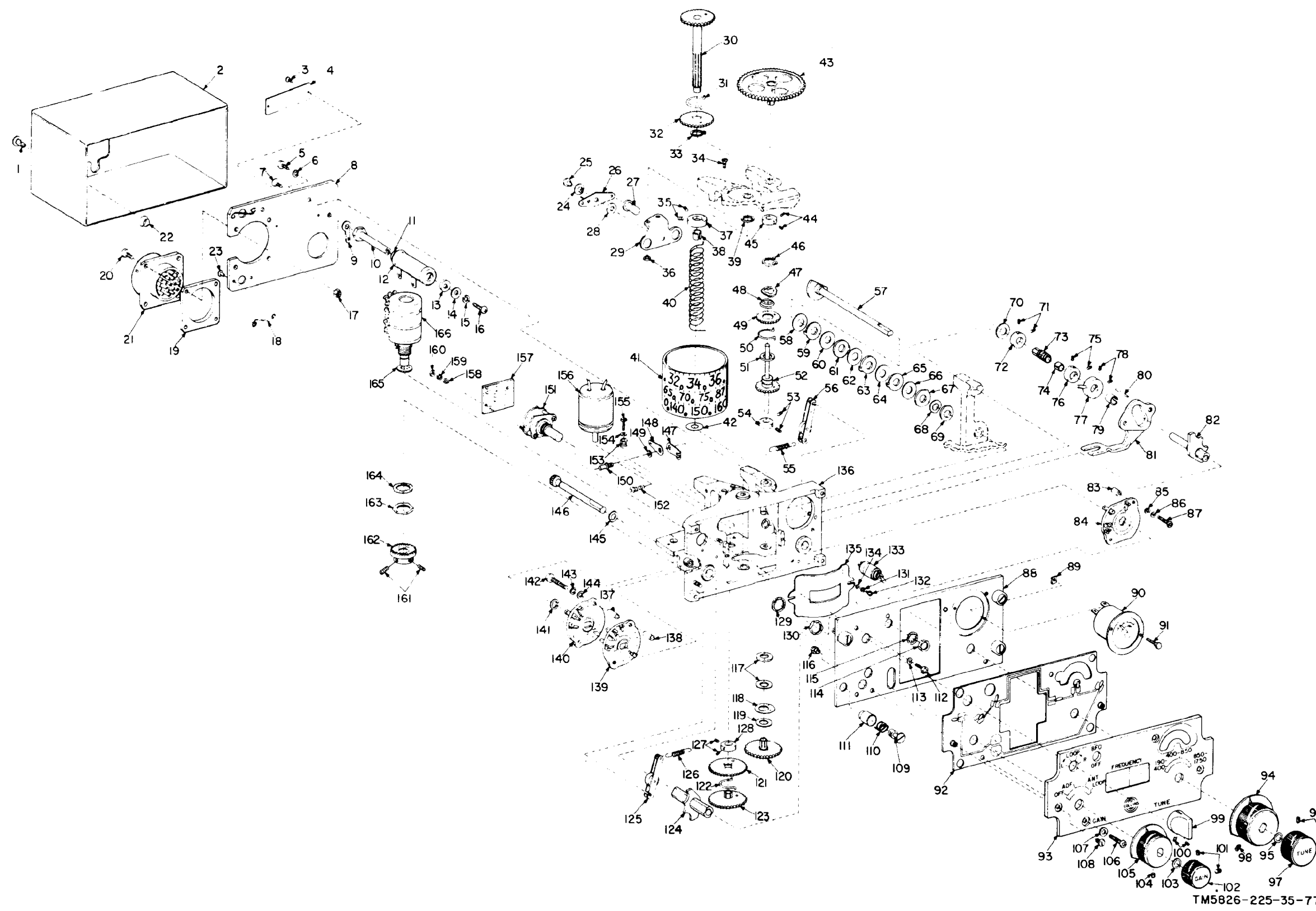

- | | | |
|--|---|--|
| 1 Stud, turnlock fastener | 56 Follower, detent | 112 Screw, machine, No. 4, 5/16 in. |
| 2 Cover, rear | 57 Stop hub assembly | |
| 3 Screw, machine, No. 2, 1/8 in. long. | 58 Washer, flat | 113 Washer, lock |
| 4 Plate, identification | 59 Washer, stop | 114 Nut, plain, hex. part of 133 |
| 5 Screw, machine, No. 4, 1/4 in. long. | 60 Washer, flat | 115 Washer, lock |
| 6 Washer, lock | 61 Washer, stop | 116 Nut, self-locking, clinch, No. 4 |
| 7 Screw machine No. 6, 3/16 in. long. | 62 Washer, flat | 117 Washer, flat |
| 8 Plate retaining | 63 Washer, stop | 118 Washer, spring tension |
| 9 Lug, solder | 64 Washer, flat | 119 Washer, flat |
| 10 Post, mounting, 1 2/5 in. lg | 65 Washer, stop | 120 Gear, spur, 60 teeth |
| 11 Insulator, washer | 66 Washer, flat | 121 Gear, spur, 60 teeth |
| 12 Resistor, fixed, R308 | 67 Washer, stop | 122 Spring, load |
| 13 Insulator, washer | 68 Washer, spring tension | 123 Gear, spur, 60 teeth |
| 14 Washer, flat | 69 Washer, flat | 124 Detent, switch |
| 15 Washer, lock | 70 Washer, flat | 125 Follower, detent |
| 16 Screw, machine, No. 6, 7/16 in. long. | 71 Screw, No. 6, set | 126 Spring, helical, extension |
| 17 Nut, self-locking, hex, No. 4 | 72 Collar, shaft | 127 Screw, No. 6, set |
| 18 Lockspring, turnlock fastener | 73 Gear, worm, 4 left-hand threads. | 128 Collar, shaft |
| 19 Plate, spacer | 74 Sleeve, bearing | 129 Washer, lock |
| 20 Screw, machine No. 4, 3/16 in. long. | 75 Screw, No. 6, set | 130 Nut, plain, hex., No. 2 |
| 21 Connector, P301 | 76 Collar, shaft | 131 Washer, lock |
| 22 Eyelet, turnlock fastener | 77 Collar, shaft | 132 Screw, machine, No. 2, 3/16 in. long. |
| 23 Rivet, tabular | 78 Screw, No. 6, set | 133 Switch, toggle, S301 |
| 24 Washer, shouldered | 79 Bearing, sleeve, split | 134 Washer, flat |
| 25 Rivet, tubular | 80 Pin, straight | 135 Mask, dial |
| 26 Clamp, electrical | 81 Level, dial drum | 136 Frame, control unit |
| 27 Lamp, incandescent, DS307, DS308 | 82 Detent, switch | 137 Spacer, sleeve, 1/4 in. long |
| 28 Washer, plastic | 83 Spacer, sleeve, 3/16 in. long | 138 Spacer, sleeve, 1/4 in. long |
| 29 Bracket, lamp | 84 Switch section, rotary, S304 | 139 Switch section, rotary, S302A |
| 30 Spur gear assembly, 61 teeth | 85 Washer, lock | 140 Switch section, rotary, S302B |
| 31 Spring load | 86 Washer, nonmetallic | 141 Ring, retaining |
| 32 Gear, spur, 61 teeth | 87 Screw, machine, No. 4, 3/8 in. long. | 142 Screw, machine, No. 4, 7/8 in. long. |
| 33 Ring, retaining | 88 Subpanel assembly, front | 143 Washer, lock |
| 34 Screw, machine, No. 2, 3/8 in. long. | 89 Nut, plain, square, No. 4 | 144 Washer, nonmetallic |
| 35 Screw, No. 6, set | 90 Ammeter, M301 | 145 Washer, spring tension |
| 36 Nut, self-locking, clinch, No. 2 | 91 Screw, machine, No. 2, 3/16 in. long. | 146 Spur gear assembly, 19 teeth |
| 37 Collar, shaft | 92 Light assembly, panel | 147 Terminal, lug |
| 38 Sleeve, bearing | 93 Panel, front | 148 Washer, lock |
| 39 Washer, flat | 94 Knob assembly, range, 04 | 149 Washer, lock |
| 40 Spring, helical, compression | 95 Washer, flat | 150 Terminal, stud (may be used in place of machine screw 152) |
| 41 Drum, dial | 96 Screw, No. 6, set | 151 Switch, rotary, S303 |
| 42 Washer, flat | 97 Knob, tune 05 | 152 Screw, machine, No. 4, 1/4 in. long. |
| 43 Gear, spur, 125 teeth | 98 Screw, No. 6, set | 153 Clamp, rim-clenching |
| 44 Screw, No. 6, set | 99 Knob, loop, 01 | 154 Washer, lock |
| 45 Collar, shaft | 100 Screw No. 6, set | 155 Screw machine, No. 2, 3/8 in. long. |
| 46 Ring, retaining | 101 Screw, No. 6, set | 156 Synchro, transmitter, B301 |
| 47 Washer, flat | 102 Knob, gain 03 | 157 Terminal board, TB1 |
| 48 Spring, helical, compression | 103 Washer, flat | 158 Washer, flat |
| 49 Gear, helical, 42 teeth | 104 Screw, No. 6, set | 159 Washer, lock |
| 50 Spring, torsion | 105 Knob assembly, function, 02 | 160 Nut, plain, hex., No. 2 |
| 51 Washer, thrust | 106 Screw, machine, No. 4, 5/16 in. long. | 161 Screw, No. 6, set |
| 52 Helical gear assembly, 42 teeth | 107 Washer, rubber | 162 Gear, crown, 48 teeth |
| 53 Screw, No. 6, set | 108 Screw, machine, No. 4, 1/8 in. long. | 163 Nut, plain, hex., part of 166 |
| 54 Collar, shaft | 109 Stud, turnlock, fastener | 164 Washer, lock |
| 55 Spring, helical, extension | 110 Stud spring, turnlock fastener | 165 Washer, lock |
| | 111 Stud sleeve, turnlock fastener | 166 Attenuator, variable, R301 |

Figure 5-17. Control unit exploded view.

INDEX

	Paragraph	Page		Paragraph	Page
Alignment:			Test _____	4-6	4-5
Control unit	3-22	3-28	Repairs:		
General - _____	3-8	3-19	Disassembly _____	3-5	3-11
Inverter, frequency adjust- ment .._ _ _ _ _	3-21.1	3-28	Reassembly and lubrica- tion - . - - - - -	3-6	3-13
Inverter voltage adjust- ment - - - - -	3-21	3-27	Troubleshooting:		
Receiver:			Localizing troubles ___	2-12	2-39
Adf hunt control, adjust ment - - - - -	3-20	3-26	Test procedure - - - - -	2-11	2-35
Audio and IF gain ad- justment	3-17	3-25	Test setup	2-10	2-35
First RF amplifier	3-16	3-24	Direction Finder Control C-6899/ ARN-83. (See control unit.)		
Function and range switch, centering adjust- m e n t .	3-11	3-20	Functioning, general :		
General	3-8	3-19	Block diagram, general system - -	1-2	1-1
Local oscillator ____	3-13	3-21	Block diagram, overall functional - - - - -	1-3	1-1
Resolver servo system	3-18	3-25	Functioning, interunit circuit:		
RF	3-14	3-22	Function and frequency selection	1-27	1-25
RF balance, adjust- ment .	3-15	3-23	General	1-26	1-25
Servo balance, adjust- ment -	3-19	3-26	Manual audio and RF gain control - .	1-30	1-27
Slow slew speed adjustment - - - - -	3-19.1	3-26.1	Manual loop control	1-29	1-27
Test equipment and addi- tional equipment	3-9	3-19	Receiver bfo switching	1-31	1-29
Tuning Capacitor, adjust- ment and synchroniza- tion	3-12	3-21	Receiver tuning	1-28	1-26
Tuning servo tachometer feedback, adjustment	3-10	3-19	Receiver tuning meter	1-32	1-30
110-Hz oscillator frequency adjustment	3-17.1	3-26	General parts replacement techniques .	3-1	3-1
90-degree phase shift adjustment	3-17.2	3-26	Periodic lubrication	3-7	3-19
Antenna, loop :			Removal and replacement techniques	3-2	3-1
Functioning, detailed	1-24	1-26	Troubleshooting,		
General support testing:			General	2-1	2-1
Physical tests and in- spection --	4-17	4-27	Organization of pro- cedures	2-2	2-1
Test -- .	4-18	4-29	Test equipment required	2-3	2-2
Troubleshooting:			Functioning, detailed.		
Test setup	2-16	2-43	Antenna	1-24	1-25
Antenna AS-1863/ARN-83. (See antenna, loop)			Control unit	1-25	1-25
Control unit:			General, additional equip- m e n t	1-22	1-22
Alignment	3-22	3-28	Inverter	1-23	1-22
Functioning, detailed	1-25	1-25	Receiver:		
General support testing:			Audio amplifiers	1-15	1-14
Physical teats and in- spection	4-5	4-3	Automatic gain control and receiver muting	1-16	1-15
			Balanced modulator	1-7	1-7
			Bfo, detector, and limiter	1-14	1-13
			General	1-4	1-5

	Paragraph	Page		Paragraph	Page
IF amplifier -----	1-13	1-12	Receiver sensitivity test ..-__	4-10	4-13
Local oscillator	1-11	1-11	Receiver tuning and switching		
Mixer ---- ----	1-12	1-12	time test	4-12	4-19
Mixer input turned			Receiver tuning meter test ____	4-14	4-23
circuits . . . -.-. _	1-10	1-9	Summary of test data -----	4-19	4-30
110-cps oscillator and			Test equipment, tools, and		
amplifier -----	1-19	1-18	materials required _____	4-2	4-1
110-cps variable phase			Test facilities	4-3	4-1
signal and synchro-					
nous filter . ---	1-17	1-15	Illustrations:		
Phase shift network and			General -----	5-1	5-1
second RF amplifier _	1-6	1-7	List of foldouts - _____	5-2	5-1
Push-pull RF amplifier _	1-9	1-9	Inverter:		
Receiver loop antenna and			Alignment _____	3-21	3-27
goniometer circuit func-			Functioning, detailed _____	1-23	1-22
tioning -----	1-5	1-5	General support testing:		
Resolver servo amplifiers _	1-18	1-17	Physical tests and inspec-		
Sense antenna input net-			tion - . . . _____	4-15	4-25
work _____	1-8	1-9	Test -----	4-16	4-27
Tuning servo amplifiers __	1-20	1-19	Troubleshooting:		
Voltage regulator . . . -	1-21	1-20	Isolating trouble within		
			a stage - -----	2-15	2-41
Functioning, Direction Finder			Localizing troubles -----	2-14	2-40
Set AN/ARN-83:			Test setup _____	2-13	2-40
Block diagram:			Loop antenna (See antenna loop)		
General system _____	1-2	1-1	Modification work orders	4-4	4-1
Overall functional _____	1-3	1-1	Periodic lubrication _____	3-7	3-19
Scope -----	1-1	1-1	Radio Receiver R-1391/ARN-83.		
Functioning, interunit circuit:			(See receiver.)		
Function and frequency			Receiver:		
selection _____	1-27	1-25	Alignment:		
General	1-26	1-25	Adf hunt control, ad-		
Manual audio and RF gain			justment -----	3-20	3-26
control -----	1-30	1-27	Audio and IF gain ad-		
Manual loop control .-.-. -	1-29	1-27	justment -----	3-17	3-25
Receiver bfo switching _	1-31	1-29	First RF amplifier _____	3-16	3-24
Receiver tuning _____	1-28	1-26	Function and range		
Receiver tuning meter ____	1-32	1-30	switch, centering ad-		
			justment _____	3-11	3-20
General support testing procedures.			General -----	3-8	3-19
Antenna AS-1863/ARN-83			Local oscillator _____	3-13	3-21
physical tests and inspec.i.			Resolver servo system, ---	3-18	3-25
tion ..- -----	4-17	4-27	RF -----	3-14	3-22
Control unit test _____	4-6	4-5	RF balance, adjustment _	3-15	3-23
Direction Finder Control			Servo balance, adjust-		
C-6899/ARN-83 physical			ment -----	3-19	3-26
tests and inspection ----	4-5	4-3	Slow slew Speed		
General _____	4-1	4-1	adjustment -----	3-19.1	3-26.1
Inverter Power, static CV-			Test equipment and addi-		
2128/ARN-83 physical tests			tional equipment -----	3-9	3-19
and inspection ---- . . .	4-15	4-25	Tuning capacitor, ajust-		
Inverter test	4-16	4-27	ment and synchroniza-		
Loop antenna test _	4-18	4-29	tion _____	3-12	3-21
Modification work orders __.	4-4	4-1	Tuning servo tachometer		
Radio Receiver R-1391/ARN-			feedback, adjustment _	3-10	3-19
83 physical test and in-			110-Hz oscillator		
spection -----	4-7	4-7	frequency		
Receiver bandwidth test _	4-9	4-11	adjustment -----	3-17.1	3-26
Receiver bearing indicator			90-degree phase		
test -..	4-11	4-17	shift adjustment -----	3-17.2	3-26
Receiver frequency accuracy					
test .	4-8	4-9			
Receiver muting test -----	4-13	4-21			

	Paragraph	Page		Paragraph	Page
Functioning, detailed:			Localizing troubles	2-5	2-4
Audio amplifiers	1-15	1-14	Signal substitution	2-6	2-22
Automatic gain control and receiver muting	1-16	1-15	Stage-gain measurements	2-7	2-25
Balanced modulator	1-7	1-7	Teste setup	2-4	2-3
Bfo, detector, and limiter	1-14	1-13	Repairs:		
General _____	1-4	1-5	Control unit:		
IF amplifiers	1-13	1-12	Disassembly	3-5	3-11
Local oscillator	1-11	1-11	Reassembly and lubrication	3-4	3-4
Mixer -----	1-12	1-12	Removal and replacement techniques	3-2	3-1
Mixer input tuned circuits	1-10	1-9	Scope -----	1-1	1-1
110-cps oscillator and amplifier _____	1-19	1-18	Summary of test data ____	4-19	4-30
110-CPS variable phase signal and synchronous filter -----	1-17	1-15	Test data, summary -----	4-19	4-30
Phase shift network and second RF amplifier .	1-6	1-7	Test equipment:		
Push-pull RF amplifier	1-9	1-9	Alignment _____	3-9	3-19
Receiver loop antenna and goniometer circuit functioning	1-5	1-5	General support testing ---	4-2	4-1
Resolver servo amplifiers _	1-18	1-17	Troubleshooting _____	2-3	2-2
Sense antenna input network _____	1-8	1-9	Test facilities -----	4-3	4-1
Tuning servo amplifiers	1-20	1-19	Troubleshooting:		
Voltage regulator _____	1-21	1-20	Antenna:		
General support testing:			Test setup _ _____	2-16	2-43
Bandwidth test _____	4-9	4-11	Control unit:		
Bearing indicator test --	4-11	4-17	Localizing troubles _____	2-12	2-39
Frequency accuracy test	4-8	4-9	Test procedure _____	2-11	2-35
Muting test -----	4-13	4-21	Test setup _____	2-10	2-35
Physical tests and inspection -----	4-7	4-7	General techniques:	2-1	2-1
Sensitivity test --- ____	4-10	4-13	Organization of procedures -----	2-2	2-1
Tuning and' switching time test -----	4-12	4-19	Test equipment required -	2-3	2-2
Tuning meter test ____	4-14	4-23	Inverter:		
Repairs:			Isolating trouble within a stage -----	2-15	2-41
Disassembly .- -----	3-3	3-1	Localizing troubles ----	2-14	2-40
Reassembly and lubrication	3-4	3-4	Test setup -----	2-13	2-40
Troubleshooting:			Receiver:		
Additional data _	2-9	2-32	Additional data _____	2-9	2-32
Isolating trouble within a stage -----	2-8	2-29	Isolating trouble within a stage -----	2-8	2-29
			Localizing troubles ... ____	2-5	2-4
			Signal substitution _____	2-6	2-22
			Stage-gain measurements --- -----	2-7	2-25
			Test setup _ . . . _____	2-4	2-3

By Order of the Secretary of the Army:

HAROLD K. JOHNSON,
General, United States Army,
Chief of Staff.

Official:

J. C. LAMBERT,
Major General, United States Army,
The Adjutant General.

Distribution:

To be distributed in accordance with DA Form 12-36 requirements for Direct and General Support (Unclas) Maintenance Literature for the OV-1A, OV-1B, OV-1C, U-8F, CH-47A, UH-1B and UH-1D Aircraft.

* U.S. GOVERNMENT PRINTING OFFICE : 1992 0 - 311-831 (43955)

